



Benchmark Example No. 43

Panel with Circular Hole

SOFiSTiK | 2023

VERiFiCATION
BE43 Panel with Circular Hole

VERiFiCATION Manual, Service Pack 2023-10 Build 44

Copyright © 2024 by SOFiSTiK AG, Nuremberg, Germany.

SOFiSTiK AG

HQ Nuremberg
Flataustraße 14
90411 Nürnberg
Germany

T +49 (0)911 39901-0
F +49(0)911 397904

Office Garching
Parkring 2
85748 Garching bei München
Germany

T +49 (0)89 315878-0
F +49 (0)89 315878-23

info@sofistik.com
www.sofistik.com

This manual is protected by copyright laws. No part of it may be translated, copied or reproduced, in any form or by any means, without written permission from SOFiSTiK AG. SOFiSTiK reserves the right to modify or to release new editions of this manual.

The manual and the program have been thoroughly checked for errors. However, SOFiSTiK does not claim that either one is completely error free. Errors and omissions are corrected as soon as they are detected.

The user of the program is solely responsible for the applications. We strongly encourage the user to test the correctness of all calculations at least by random sampling.

Front Cover

Volkstheater, Munich Photo: Florian Schreiber

Overview

Element Type(s): C3D

Analysis Type(s): STAT

Procedure(s):

Topic(s):

Module(s): ASE

Input file(s): [structured_mesh.dat](#) , [unstructured_mesh.dat](#)

1 Problem Description

The problem consists of a rectangular panel with a circular hole in its middle, loaded by a constant linear load p on the vertical edges, as shown in Fig. 1. The system is modelled as a plane stress problem and the maximum stress at the edge of the hole is determined and verified for various meshes [1].

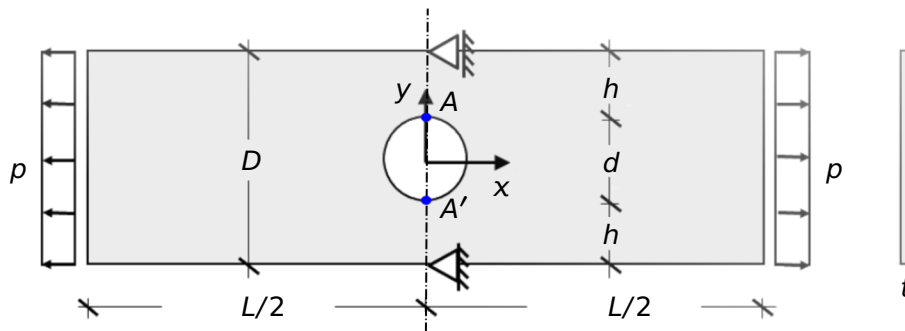

Figure 1: Problem Description

2 Reference Solution

The maximum stress $\sigma_{A,xx,max}$ resulting from a load p , at the edge of the hole can be determined at points A and A' across a vertical cut, visualised in Fig. 1, as follows [2] [3]:

$$\sigma_{A,xx,max} = K_t \cdot \sigma_{xx,nom} \quad (1)$$

where

$$P = p \cdot D = 1000 \quad [kN] \quad (2)$$

$$\sigma_{xx,nom} = \frac{P}{t \cdot (D - d)} = 33.33 \quad [N/mm^2] \quad (3)$$

$$K_t = 3.000 - 3.140 \cdot (d/D) + 3.667 \cdot (d/D)^2 - 1.527 \cdot (d/D)^3, \quad (0 < d/D < 1) \quad (4)$$

3 Model and Results

The properties of the model are defined in Table 1. Plane stress conditions are assumed, with two degrees of freedom, u_x , u_y , per node, and a line load $p = 200.0 \text{ kN/m}$ is applied at both vertical ends. The length of the panel is considered to be large enough in order to avoid any disturbances in the area of the hole, due to the loaded ends. Due to symmetry conditions only one fourth of the panel is modelled.

Table 1: Model Properties

| Material Properties | Geometric Properties | Loading |
|----------------------------------|------------------------------------------|--------------------------|
| $E = 2.1 \cdot 10^5 \text{ MPa}$ | $L = 15.00 \text{ m}$ | $p = 200.0 \text{ kN/m}$ |
| $\nu = 0.30$ | $D = 5.00 \text{ m}, d = 2.00 \text{ m}$ | |
| | $h = 1.50 \text{ m}, t = 0.01 \text{ m}$ | |

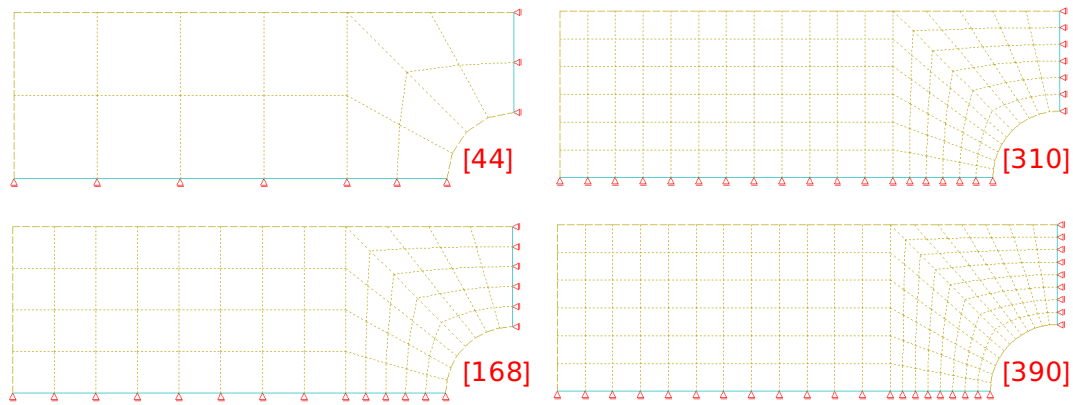

(a) Structured Meshing

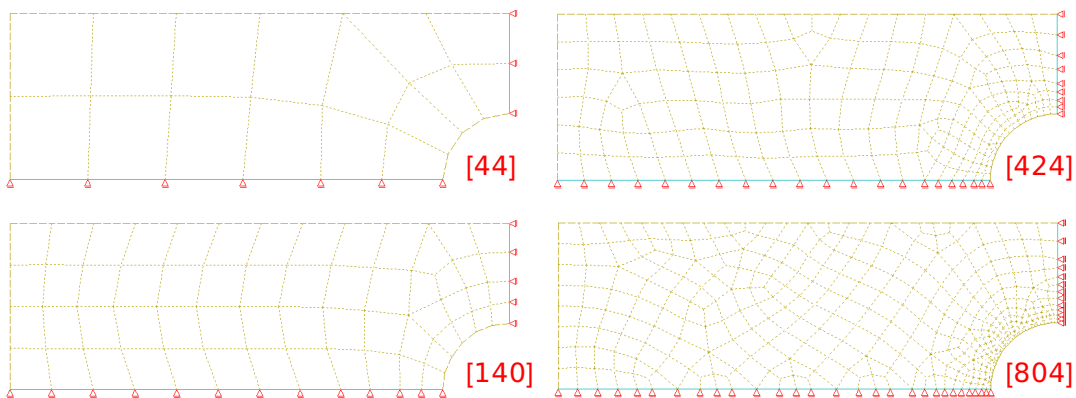

(b) Unstructured Meshing

Figure 2: FEM Models

Four manually structured meshes, with refinement around the hole area, are considered, shown in Fig. 2(a), with increasing number of quadrilateral elements and the convergence behaviour is evaluated. For the sake of comparison, unstructured meshes, shown in Fig. 2(b), are also considered. The number of degrees of freedom for every mesh is given in the red brackets. The results are presented in Fig 3 where

they are compared to the analytical solution calculated from the formulas presented in Section 2. For the case of structured meshing two element formulations are considered. The first one, represented by the red curve, corresponds to the 4-node regular conforming element whereas the second, represented by the purple curve corresponds to the non-conforming element with six functions. The blue curve represents the unstructured meshing.

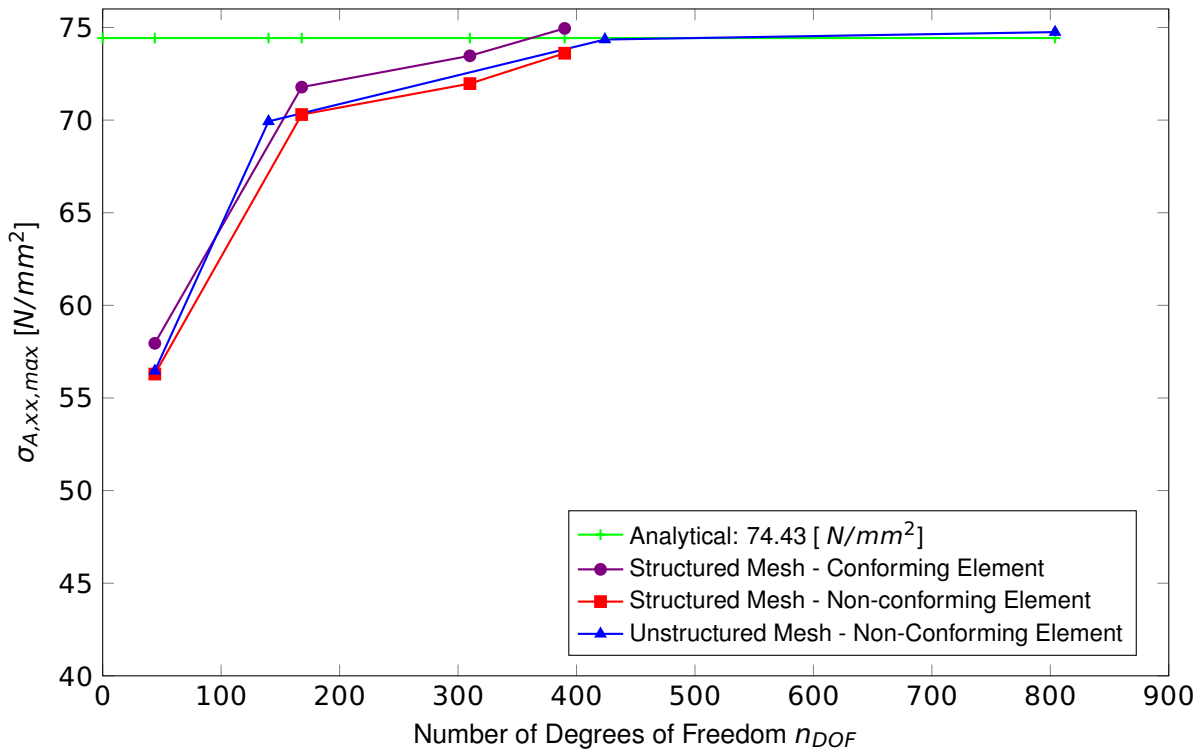

Figure 3: Convergence Diagram



Figure 4: Maximum Stresses $\sigma_{xx,max}$

The regular 4-node element is characterised through a bilinear accretion of the displacements and rotations. This element is called conforming, because the displacements and the rotations between elements do not have any jumps. The results at the gravity centre of the element represent the actual internal force variation fairly well, while the results at the corners are relatively useless, especially the ones at the edges or at the corners of a region. On the other hand the non-conforming elements, are based one the idea of describing more stress states through additional functions that their value is zero at all nodes. As a rule, these functions lead to a substantial improvement of the results, however, they violate the continuity of displacements between elements and thus they are called non-conforming.

4 Conclusion

The example allows the verification of the calculation of plane stress problems and the convergence behaviour of quadrilateral elements. For both types of elements, the calculated results converge rather fast to the predetermined precise analytical solution, within acceptable tolerance range. Furthermore, it is evident that the unstructured mesh, which is a more often choice in practice, gives results which are in very good agreement with the analytical solution.

5 Literature

- [1] VDI 6201 *Beispiel: Softwaregestützte Tragwerksberechnung - Beispiel Scheibe mit kreisförmigem Loch - Konvergenztest für Scheibenelemente, Kategorie 1: Mechanische Grundlagen*. Verein Deutscher Ingenieure e. V.
 - [2] C. Petersen. *Stahlbau. Grundlagen der Berechnung und baulichen Ausbildung von Stahlbauten*. Vieweg, 1997.
 - [3] W. D. Pilkey. *Formulaes for Stress, Strain and Structural Matrices*. Wileys & Sons, 1994.
-