



# VERiFiCATION

Design Code Benchmarks

## **VERiFiCATION**

VERiFiCATION Manual, Service Pack 2022-7 Build 23

Copyright © 2022 by SOFiSTiK AG, Nuremberg, Germany.

### **SOFiSTiK AG**

HQ Nuremberg  
Flataustraße 14  
90411 Nürnberg  
Germany

T +49 (0)911 39901-0  
F +49(0)911 397904

Office Garching  
Parkring 2  
85748 Garching bei München  
Germany

T +49 (0)89 315878-0  
F +49 (0)89 315878-23

[info@sofistik.com](mailto:info@sofistik.com)  
[www.sofistik.com](http://www.sofistik.com)

This manual is protected by copyright laws. No part of it may be translated, copied or reproduced, in any form or by any means, without written permission from SOFiSTiK AG. SOFiSTiK reserves the right to modify or to release new editions of this manual.

The manual and the program have been thoroughly checked for errors. However, SOFiSTiK does not claim that either one is completely error free. Errors and omissions are corrected as soon as they are detected.

The user of the program is solely responsible for the applications. We strongly encourage the user to test the correctness of all calculations at least by random sampling.

#### **Front Cover**

Arnulfsteg, Munich Photo: Hans Gössing

## Contents

<b>Introduction</b>	<b>3</b>
<b>1 About this Manual</b>	<b>3</b>
1.1 Layout and Organization of a Benchmark .....	3
1.2 Finding the Benchmark of interest.....	3
1.3 Symbols .....	5
<b>2 Index by Categories</b>	<b>7</b>
2.1 Design Code Benchmarks.....	7
<b>I SOFiSTiK Software Quality Assurance (SQA)</b>	<b>9</b>
<b>3 SOFiSTiK SQA Policy</b>	<b>11</b>
3.1 Objectives .....	11
3.1.1 About SOFiSTiK .....	11
3.1.2 Innovation and Reliability .....	11
3.2 Organisation .....	11
3.2.1 Software Release Schedule .....	11
3.2.2 SQA Modules - Classification .....	12
3.2.3 Responsibilities .....	12
3.2.4 Software Release Procedure .....	13
3.3 Instruments.....	14
3.3.1 CRM System .....	14
3.3.2 Tracking System (internal) .....	14
3.3.3 Continuous Integration – Continuous Testing.....	14
3.4 Additional Provisions.....	15
3.4.1 Training.....	15
3.4.2 Academia Network .....	15
3.5 Disclaimer .....	16
<b>II Design Code Benchmarks</b>	<b>17</b>
<b>4 DCE-EN1: Design of Slab for Bending</b>	<b>19</b>
4.1 Problem Description.....	19
4.2 Reference Solution .....	19
4.3 Model and Results .....	20
4.4 Design Process .....	21
4.5 Conclusion .....	22
4.6 Literature .....	22
<b>5 DCE-EN2: Design of a Rectangular CS for Bending</b>	<b>23</b>
5.1 Problem Description.....	23
5.2 Reference Solution .....	23
5.3 Model and Results .....	24

5.4	Design Process .....	25
5.5	Conclusion .....	27
5.6	Literature .....	27
<b>6</b>	<b>DCE-EN3: Design of a T-section for Bending</b>	<b>29</b>
6.1	Problem Description.....	29
6.2	Reference Solution .....	29
6.3	Model and Results .....	30
6.4	Design Process .....	32
6.5	Conclusion .....	34
6.6	Literature .....	34
<b>7</b>	<b>DCE-EN4: Design of a Rectangular CS for Bending and Axial Force</b>	<b>35</b>
7.1	Problem Description.....	35
7.2	Reference Solution .....	35
7.3	Model and Results .....	36
7.4	Design Process .....	37
7.5	Conclusion .....	38
7.6	Literature .....	38
<b>8</b>	<b>DCE-EN5: Design of a Rectangular CS for Double Bending and Axial Force</b>	<b>39</b>
8.1	Problem Description.....	39
8.2	Reference Solution .....	39
8.3	Model and Results .....	40
8.4	Design Process .....	42
8.5	Conclusion .....	43
8.6	Literature .....	43
<b>9</b>	<b>DCE-EN6: Design of a Rectangular CS for Shear Force</b>	<b>45</b>
9.1	Problem Description.....	45
9.2	Reference Solution .....	45
9.3	Model and Results .....	46
9.4	Design Process .....	47
9.5	Conclusion .....	49
9.6	Literature .....	49
<b>10</b>	<b>DCE-EN7: Design of a T-section for Shear</b>	<b>51</b>
10.1	Problem Description.....	51
10.2	Reference Solution .....	51
10.3	Model and Results .....	52
10.4	Design Process .....	54
10.5	Conclusion .....	57
10.6	Literature .....	57
<b>11</b>	<b>DCE-EN8: Design of a Rectangular CS for Shear and Axial Force</b>	<b>59</b>
11.1	Problem Description.....	59
11.2	Reference Solution .....	59
11.3	Model and Results .....	60
11.4	Design Process .....	61
11.5	Conclusion .....	63
11.6	Literature .....	63
<b>12</b>	<b>DCE-EN9: Design of a Rectangular CS for Shear and Torsion</b>	<b>65</b>
12.1	Problem Description.....	65
12.2	Reference Solution .....	65

12.3	Model and Results .....	66
12.4	Design Process .....	68
12.5	Conclusion .....	71
12.6	Literature .....	71
<b>13</b>	<b>DCE-EN10: Shear between web and flanges of T-sections</b>	<b>73</b>
13.1	Problem Description.....	73
13.2	Reference Solution .....	73
13.3	Model and Results .....	74
13.4	Design Process .....	76
13.5	Conclusion .....	79
13.6	Literature .....	79
<b>14</b>	<b>DCE-EN11: Shear at the interface between concrete cast</b>	<b>81</b>
14.1	Problem Description.....	81
14.2	Reference Solution .....	81
14.3	Model and Results .....	82
14.4	Design Process .....	83
14.5	Conclusion .....	86
14.6	Literature .....	86
<b>15</b>	<b>DCE-EN12: Crack width calculation of reinforced beam acc. DIN EN 1992-1-1</b>	<b>87</b>
15.1	Problem Description.....	87
15.2	Reference Solution .....	87
15.3	Model and Results .....	88
15.4	Design Process .....	90
15.5	Conclusion .....	95
15.6	Literature .....	95
<b>16</b>	<b>DCE-EN13: Design of a Steel I-section for Bending and Shear</b>	<b>97</b>
16.1	Problem Description.....	97
16.2	Reference Solution .....	97
16.3	Model and Results .....	97
16.4	Design Process .....	99
16.5	Conclusion .....	102
16.6	Literature .....	103
<b>17</b>	<b>DCE-EN14: Classification of Steel Cross-sections</b>	<b>105</b>
17.1	Problem Description.....	105
17.2	Reference Solution .....	105
17.3	Model and Results .....	106
17.4	Design Process .....	108
17.5	Conclusion .....	109
17.6	Literature .....	109
<b>18</b>	<b>DCE-EN15: Buckling Resistance of Steel Members</b>	<b>111</b>
18.1	Problem Description.....	111
18.2	Reference Solution .....	111
18.3	Model and Results .....	111
18.4	Design Process .....	113
18.5	Conclusion .....	114
18.6	Literature .....	114
<b>19</b>	<b>DCE-EN17: Stress Calculation at a Rectangular Prestressed Concrete CS</b>	<b>115</b>
19.1	Problem Description.....	115

19.2	Reference Solution .....	115
19.3	Model and Results .....	116
19.4	Design Process .....	118
19.5	Conclusion .....	121
19.6	Literature .....	121
<b>20</b>	<b>DCE-EN18: Creep and Shrinkage Calculation of a Rectangular Prestressed Concrete CS</b>	<b>123</b>
20.1	Problem Description.....	123
20.2	Reference Solution .....	123
20.3	Model and Results .....	124
20.4	Design Process .....	125
20.5	Conclusion .....	129
20.6	Literature .....	129
<b>21</b>	<b>DCE-EN19: Fatigue of a Rectangular Reinforced Concrete CS</b>	<b>131</b>
21.1	Problem Description.....	131
21.2	Reference Solution .....	131
21.3	Model and Results .....	131
21.4	Design Process .....	133
21.5	Conclusion .....	140
21.6	Literature .....	140
<b>22</b>	<b>DCE-EN20: Design of a Steel I-section for Bending, Shear and Axial Force</b>	<b>141</b>
22.1	Problem Description.....	141
22.2	Reference Solution .....	142
22.3	Model and Results .....	142
22.4	Design Process .....	143
22.5	Conclusion .....	146
22.6	Literature .....	147
<b>23</b>	<b>DCE-EN21: Real Creep and Shrinkage Calculation of a T-Beam Prestressed CS</b>	<b>149</b>
23.1	Problem Description.....	149
23.2	Reference Solution .....	149
23.3	Model and Results .....	149
23.4	Design Process .....	152
23.5	Conclusion .....	163
23.6	Literature .....	163
<b>24</b>	<b>DCE-EN22: Stress Relaxation of Prestressing Steel - EN 1992-1-1</b>	<b>165</b>
24.1	Problem Description.....	165
24.2	Reference Solution .....	165
24.3	Model and Results .....	165
24.4	Design Process .....	167
24.5	Conclusion .....	171
24.6	Literature .....	171
<b>25</b>	<b>DCE-EN23: Stress Relaxation of Prestressing Steel - DIN EN 1992-1-1</b>	<b>173</b>
25.1	Problem Description.....	173
25.2	Reference Solution .....	173
25.3	Model and Results .....	173
25.4	Design Process .....	175
25.5	Conclusion .....	179
25.6	Literature .....	179

<b>26</b>	<b>DCE-EN24: Lateral Torsional Buckling</b>	<b>181</b>
26.1	Problem Description.....	181
26.2	Reference Solution .....	181
26.3	Model and Results .....	182
26.4	Design Process .....	184
26.5	Conclusion .....	191
26.6	Literature .....	191
<b>27</b>	<b>DCE-EN25: Shear between web and flanges of Hollow CS acc. DIN EN 1992-2</b>	<b>193</b>
27.1	Problem Description.....	193
27.2	Reference Solution .....	193
27.3	Model and Results .....	194
27.4	Design Process .....	197
27.5	Conclusion .....	202
27.6	Literature .....	203
<b>28</b>	<b>DCE-EN27: Design of Quad Elements - Layer Design and Baumann Method</b>	<b>205</b>
28.1	Problem Description.....	205
28.2	Reference Solution .....	205
28.3	Model and Results .....	206
28.4	Design Process .....	210
28.5	Conclusion .....	217
28.6	Literature .....	217
<b>29</b>	<b>DCE-EN28: Design of a T-section for bending and shear using Design Elements</b>	<b>219</b>
29.1	Problem Description.....	219
29.2	Reference Solution .....	219
29.3	Model and Results .....	219
29.4	Design Process .....	222
29.5	Conclusion .....	224
29.6	Literature .....	224
<b>30</b>	<b>DCE-EN29: Design of restrained steel column</b>	<b>225</b>
30.1	Problem Description.....	225
30.2	Reference Solution .....	226
30.3	Model and Results .....	226
30.4	Design Process .....	228
30.5	Conclusion .....	232
30.6	Literature .....	232
<b>31</b>	<b>DCE-EN30: Steel column with a class 4 cross-section</b>	<b>233</b>
31.1	Problem Description.....	233
31.2	Reference Solution .....	234
31.3	Model and Results .....	235
31.4	Design Process .....	236
31.5	Conclusion .....	244
31.6	Literature .....	244
<b>32</b>	<b>DCE-EN31: Punching of flat slab acc. DIN EN 1992-1-1</b>	<b>247</b>
32.1	Problem Description.....	247
32.2	Reference Solution .....	248
32.3	Model and Results .....	248
32.4	Design Process .....	250
32.4.1	Material .....	250

32.4.2	Actions and Loads .....	250
32.4.3	Punching check for inner Column .....	250
32.4.4	Punching check for edge column .....	255
32.4.5	Punching check for wall .....	258
32.5	Conclusion .....	263
32.6	Literature .....	263
<b>33</b>	<b>DCE-EN32: Crack width calculation of reinforced slab acc. DIN EN 1992-1-1</b>	<b>265</b>
33.1	Problem Description .....	265
33.2	Reference Solution .....	265
33.3	Model and Results .....	266
33.4	Design Process .....	269
33.4.1	Material .....	269
33.4.2	Without direct calculation .....	269
33.4.3	With direct calculation .....	270
33.5	Conclusion .....	273
33.6	Literature .....	273
<b>34</b>	<b>DCE-EN33: Designing a Reinforced Concrete Column acc. DIN EN 1992-1-1</b>	<b>275</b>
34.1	Problem Description .....	275
34.2	Reference Solution .....	275
34.3	Model and Results .....	276
34.4	Design Process .....	278
34.4.1	Exposure class .....	278
34.4.2	Actions .....	278
34.4.3	Materials .....	278
34.4.4	Buckling length .....	279
34.4.5	Imperfections .....	280
34.4.6	Min. and max. required reinforcement .....	280
34.4.7	Design of longitudinal reinforcement .....	280
34.4.8	Design of shear reinforcement .....	283
34.5	Conclusion .....	284
34.6	Literature .....	285
<b>35</b>	<b>DCE-EN34: Elastic Critical Plate Buckling Stress</b>	<b>287</b>
35.1	Problem Description .....	287
35.2	Reference Solution .....	288
35.3	Model and Results .....	288
35.4	Design Process .....	291
35.4.1	Klöppel .....	291
35.4.2	EBPlate .....	291
35.4.3	EN 1993-1-5, Annex A.2 .....	293
35.4.4	ABAQUS .....	296
35.5	Conclusion .....	297
35.6	Literature .....	297
<b>36</b>	<b>DCE-MC1: Creep and Shrinkage Calculation using the Model Code 2010</b>	<b>299</b>
36.1	Problem Description .....	299
36.2	Reference Solution .....	299
36.3	Model and Results .....	299
36.4	Design Process .....	301
36.5	Conclusion .....	305
36.6	Literature .....	305



<b>37</b>	<b>DCE-MC2: Creep and Shrinkage Calculation using the Model Code 1990</b>	<b>307</b>
37.1	Problem Description.....	307
37.2	Reference Solution .....	307
37.3	Model and Results .....	307
37.4	Design Process .....	309
37.5	Conclusion .....	312
37.6	Literature .....	312
<b>38</b>	<b>DCE-SIA1: Punching of flat slabs acc. SIA 262</b>	<b>313</b>
38.1	Problem Description.....	313
38.2	Reference Solution .....	315
38.3	Model and Results .....	315
38.4	Design Process .....	316
38.5	Conclusion .....	321
38.6	Literature .....	321



# Introduction



# 1 About this Manual

The primary objective of this manual is to verify the capabilities of SOFiSTiK by means of nontrivial problems which are bound to reference solutions.

To this end, this manual contains a compilation of a number of selected computational benchmarks, each benchmark focusing on a specific (mechanical/design) topic. The obtained results from the SOFiSTiK analysis are contrasted with corresponding reference solutions<sup>1</sup>.

The tasks covered by SOFiSTiK, address a broad scope of engineering applications and it is therefore not possible to validate all specific features with known reference solutions in terms of this Verification Manual. An attempt has been made though, to include most significant features of the software with respect to common problems of general static and dynamic analysis of structures.

## 1.1 Layout and Organization of a Benchmark

For the description of each Benchmark, a standard format is employed, where the following topics are always treated:

- Problem Description
- Reference Solution
- Model and Results
- Conclusion
- Literature

First, the problem description is given, where the target of the benchmark is stated, followed by the reference solution, where usually a closed-form analytical solution is presented, when available. The next section is the description of the model, where its properties, the loading configuration, the analysis method and assumptions, further information on the finite element model, are presented in detail. Finally, the results are discussed and evaluated with respect to the reference solution and a final conclusion for the response of the software to the specific problem is drawn. Last but not least, the textbooks and references used for the verification examples are listed, which are usually well known and come from widely acclaimed engineering literature sources.

## 1.2 Finding the Benchmark of interest

There are several ways of locating a Benchmark that is of interest for the user. For each example a description table is provided in the beginning of the document, where all corresponding categories, that are treated by the specific benchmark, are tabulated, as well as the name of the corresponding input file. Such a description table with some example entries, follows next.

Overview	
<b>Element Type(s):</b>	C2D
<b>Analysis Type(s):</b>	STAT, MNL
<b>Procedure(s):</b>	LSTP

<sup>1</sup>Where available, analytical solutions serve as reference. Where this is not feasible, numerical or empirical solutions are referred to. In any case, the origin of the reference solution is explicitly stated.

<b>Topic(s):</b>	SOIL
<b>Module(s):</b>	TALPA
<b>Input file(s):</b>	<a href="#">passive_earth_pressure.dat</a>

As it can be seen, the available categories are the element type, the analysis type, the procedure, the topics and the modules. For each category that is provided in the description table, a hyperlink is created, linking each example to the global categories tables. In this manner, the user has a direct overview of the attributes involved in each problem, and at the same time is able to browse by category through the Verification Manual focusing only on the one of his interest. Table 1.1 provides an overview of all the categories options that are available.

Table 1.1: Categories Overview

Categories	Options
Element Type	Continuum 3D
	Continuum 2D (plane strain)
	Continuum axisymmetric
	Shell
	FE beam 3D
	Nonlinear FE beam 3D (AQB)
	Fiber beam 2D
	Fiber beam 3D
	Truss element
	Cable element
	Spring element
	Damping element
Analysis Type	Couplings
	Geometrically nonlinear
	Physically nonlinear
	Dynamic
Procedure	Static
	Potential problem
	Buckling analysis
	Eigenvalue/ Modal analysis
Topic	Time stepping
	Load stepping
	Phi-C reduction
	Soil related
	Seismic

Table 1.1: (continued)

Categories	Options
	Fire design
Module	AQB
	AQUA
	ASE
	BDK
	BEMESS
	CSM
	DYNA
	SOFiLOAD
	SOFiMSHC
	STAR2
	TALPA
	TENDON

### 1.3 Symbols

For the purpose of this manual the following symbols and abbreviations apply.

SOF.	SOFISTIK
Ref.	reference
Tol.	tolerance
cs	cross-section
sect.	section
temp.	temperature
homog.	homogeneous
Be.	benchmark
con.	construction
SDOF	single degree of freedom
$e_r$	relative error of the approximate number
$ e_r $	absolute relative error of the approximate number
$e$	error of the approximate number
$ e $	absolute error of the approximate number
$exp()$	same as $e^()$





## 2 Index by Categories

Subsequent tables show all Benchmarks included in this Verification Manual, indexed by category.

### 2.1 Design Code Benchmarks

DESIGN CODE FAMILY	Keyword	Benchmark Examples
Eurocodes	EN	DCE-EN6, DCE-EN7, DCE-EN13, DCE-EN14, DCE-EN15, DCE-EN20, DCE-EN21, DCE-EN22, DCE-EN24, DCE-EN27, DCE-EN30, DCE-EN34
German Standards	DIN	DCE-EN1, DCE-EN2, DCE-EN3, DCE-EN4, DCE-EN5, DCE-EN6, DCE-EN8, DCE-EN9, DCE-EN10, DCE-EN11, DCE-EN12, DCE-EN17, DCE-EN18, DCE-EN19, DCE-EN23, DCE-EN25, DCE-EN28, DCE-EN29, DCE-EN31, DCE-EN32, DCE-EN33
CEB-FIB Model Code	MC	DCE-MC1, DCE-MC2
Swiss Standards	SIA	DCE-SIA1

DESIGN CODE	Keyword	Benchmark Examples
Eurocode for Design of Concrete Structures - General rules and rules for buildings	EN 1992-1-1	DCE-EN1, DCE-EN2, DCE-EN3, DCE-EN4, DCE-EN5, DCE-EN6, DCE-EN7, DCE-EN8, DCE-EN9, DCE-EN10, DCE-EN11, DCE-EN12, DCE-EN17, DCE-EN18, DCE-EN19, DCE-EN21, DCE-EN22, DCE-EN23, DCE-EN25, DCE-EN27, DCE-EN28, DCE-EN31, DCE-EN32, DCE-EN33
Eurocode for Design of Concrete Structures - Concrete bridges	EN 1992-2	DCE-EN25
Eurocode for Design of Steel Structures - General rules and rules for buildings	EN 1993-1-1	DCE-EN13, DCE-EN14, DCE-EN15, DCE-EN20, DCE-EN24, DCE-EN29, DCE-EN30, DCE-EN34

*Table continued on next page.*

<b>DESIGN CODE</b>	<b>Keyword</b>	<b>Benchmark Examples</b>
Eurocode for Design of Concrete Structures - General rules and rules for building incl. German National Annex	DIN EN 1992-1-1	<a href="#">DCE-EN1</a> , <a href="#">DCE-EN2</a> , <a href="#">DCE-EN3</a> , <a href="#">DCE-EN4</a> , <a href="#">DCE-EN5</a> , <a href="#">DCE-EN6</a> , <a href="#">DCE-EN7</a> , <a href="#">DCE-EN8</a> , <a href="#">DCE-EN9</a> , <a href="#">DCE-EN10</a> , <a href="#">DCE-EN11</a> , <a href="#">DCE-EN12</a> , <a href="#">DCE-EN17</a> , <a href="#">DCE-EN18</a> , <a href="#">DCE-EN19</a> , <a href="#">DCE-EN21</a> , <a href="#">DCE-EN22</a> , <a href="#">DCE-EN23</a> , <a href="#">DCE-EN25</a> , <a href="#">DCE-EN27</a> , <a href="#">DCE-EN28</a> , <a href="#">DCE-EN31</a> , <a href="#">DCE-EN32</a> , <a href="#">DCE-EN33</a>
Eurocode for Design of Concrete Structures - Concrete bridges incl. German National Annex	DIN EN 1992-2	<a href="#">DCE-EN25</a>
Eurocode for Design of Steel Structures - General rules and rules for buildings incl. German National Annex	DIN EN 1993-1-1	<a href="#">DCE-EN13</a> , <a href="#">DCE-EN14</a> , <a href="#">DCE-EN15</a> , <a href="#">DCE-EN20</a> , <a href="#">DCE-EN24</a> , <a href="#">DCE-EN29</a> , <a href="#">DCE-EN30</a> , <a href="#">DCE-EN34</a>
CEB-FIP Model Code for Concrete Structures 1990	MC 1990	<a href="#">DCE-MC2</a>
CEB-FIP Model Code for Concrete Structures 2010	MC 2010	<a href="#">DCE-MC1</a>
Swiss Standard for Concrete Structures	SIA 262	<a href="#">DCE-SIA1</a>

<b>MODULE</b>	<b>Keyword</b>	<b>Benchmark Examples</b>
Design of Cross Sections and of Prestressed Concrete and Composite Cross Sections	AQB	<a href="#">DCE-EN1</a> , <a href="#">DCE-EN2</a> , <a href="#">DCE-EN3</a> , <a href="#">DCE-EN4</a> , <a href="#">DCE-EN5</a> , <a href="#">DCE-EN6</a> , <a href="#">DCE-EN7</a> , <a href="#">DCE-EN8</a> , <a href="#">DCE-EN9</a> , <a href="#">DCE-EN10</a> , <a href="#">DCE-EN11</a> , <a href="#">DCE-EN12</a> , <a href="#">DCE-EN13</a> , <a href="#">DCE-EN14</a> , <a href="#">DCE-EN17</a> , <a href="#">DCE-EN18</a> , <a href="#">DCE-EN19</a> , <a href="#">DCE-EN20</a> , <a href="#">DCE-EN22</a> , <a href="#">DCE-EN23</a> , <a href="#">DCE-EN25</a> , <a href="#">DCE-EN28</a> , <a href="#">DCE-EN30</a> , <a href="#">DCE-MC1</a> , <a href="#">DCE-MC2</a>
Lateral Torsional Buckling Check for Steel Cross Sections	BDK	<a href="#">DCE-EN15</a> , <a href="#">DCE-EN24</a> , <a href="#">DCE-EN29</a> , <a href="#">DCE-EN30</a>
Design of Plates and Shells	BEMESS	<a href="#">DCE-EN27</a> , <a href="#">DCE-EN31</a> , <a href="#">DCE-EN32</a> <a href="#">DCE-SIA1</a>
Geometry of Prestressing Tendons	TENDON	<a href="#">DCE-EN17</a>
Construction Stage Manager	CSM	<a href="#">DCE-EN18</a> , <a href="#">DCE-EN21</a> , <a href="#">DCE-MC1</a> , <a href="#">DCE-MC2</a>

## Part I

# SOFiSTiK Software Quality Assurance (SQA)



### 3 SOFiSTiK SQA Policy

#### 3.1 Objectives

##### 3.1.1 About SOFiSTiK

SOFiSTiK finite element software has been continuously developed since 1981. It is currently used by more than 10000 customers worldwide. SOFiSTiK is a multipurpose tool with extensive capabilities which fall into a wide spectrum of engineering analyses such as static and dynamic structural analysis, modal and buckling eigenvalue problems, nonlinearities and higher order effects, geotechnics and tunnel analysis, heat transfer and fire analysis, as well as numerous types of other applications.

##### 3.1.2 Innovation and Reliability

As a provider of cutting-edge engineering software, confidence in robustness and reliability of the product is an issue of outstanding relevance for SOFiSTiK. To some degree, however, innovation and reliability are conflicting targets, since every change introduces new possible sources of uncertainty and error. To meet both demands on a sustainable basis, SOFiSTiK has installed a comprehensive quality assurance system. The involved organizational procedures and instruments are documented in the following Sections.

#### 3.2 Organisation

##### 3.2.1 Software Release Schedule

SOFiSTiK is now switching to a yearly release cycle for all SOFiSTiK products (incl. current OEMs) with a service period of 3 years. Meaning the next release 2023 will not only be a BIM App and compatibility release for SOFiCAD and SOFiPLUS, but also a release of the FEA products including latest OEM versions: e.g. SOFiSTiK — 2023.

The first customer shipment (FCS) of a SOFiSTiK major release is preceded by an extensive testing period. The major release cycle is supplemented by a two-month service pack cycle. Service packs are quality assured, which means they have passed both the continuous testing procedures and the functional tests. They are available for download via the SOFiSTiK update tool [SOFiSTiK Application Manager \(SAM\)](#).

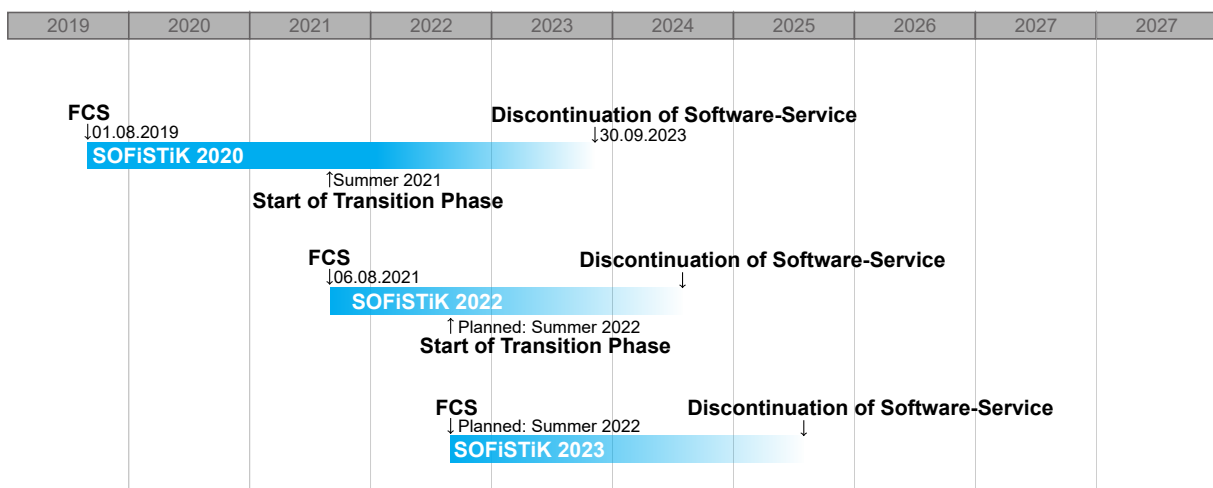

Figure 3.1: SOFiSTiK Release Schedule

Software updates for the current version (service packs) include bug-fixes and minor new features. Major new developments with increased potential regarding side-effects are reserved for major releases with an obligatory extensive testing period.

### 3.2.2 SQA Modules - Classification

Figure 3.2 depicts the "three pillars" of the SOFiSTiK SQA procedure. Preventive and analytic provisions can be differentiated.

Preventive provisions essentially concern the organization of the *development process*. They aim at minimizing human errors by a high degree of automatism and by avoiding error-prone stress situations. These provisions comprise:

- A thoroughly planned feature map and release schedule.
- Strict phase differentiation: Prior to any software release (also for service packs), the *development phase* is followed up by a *consolidation phase*. This phase is characterized by extensive functional testing. No new features are implemented, only test feedback is incorporated. For major releases, an additional *BETA test phase* is scheduled.
- Fully automated build and publishing mechanisms.

Analytic provisions provide for the actual testing of the software products. *Continuous Testing* directly accompanies the development process: Automated and modular regression tests assure feedback at a very early stage of the development (Section 3.3.3: Continuous Testing). *Functional Testing* is carried out in particular during the consolidation phases. These tests essentially involve manual testing; they focus on comprehensive workflow tests and product oriented semantic tests.

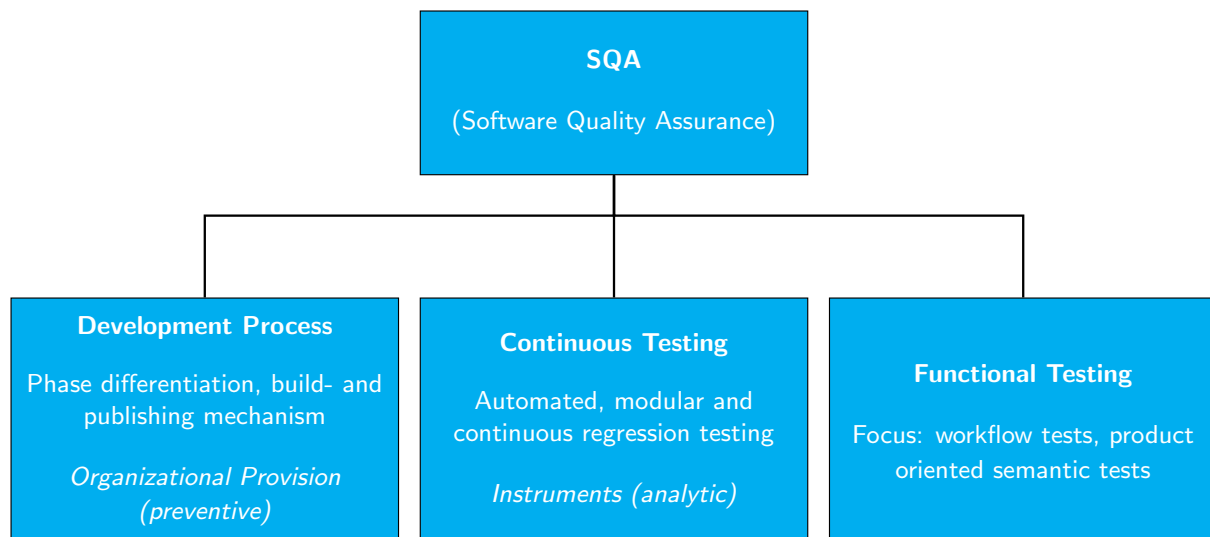

Figure 3.2: SQA Modules

### 3.2.3 Responsibilities

The consistent implementation of quality assurance procedures is responsibly coordinated by the managing board executive for products.

The development divisions are in authority for:

- The establishment, maintenance and checking of continuous testing procedures.
- The implementation of corresponding feedback.

The product management is responsible for:

- The coordination and execution of functional testing.
- The integration of customer feedback into the QA process.

As a corporate activity is carried out:

- Continuous review of processes.
- The identification of supplemental objectives.
- Identification and implementation of possible optimizations.

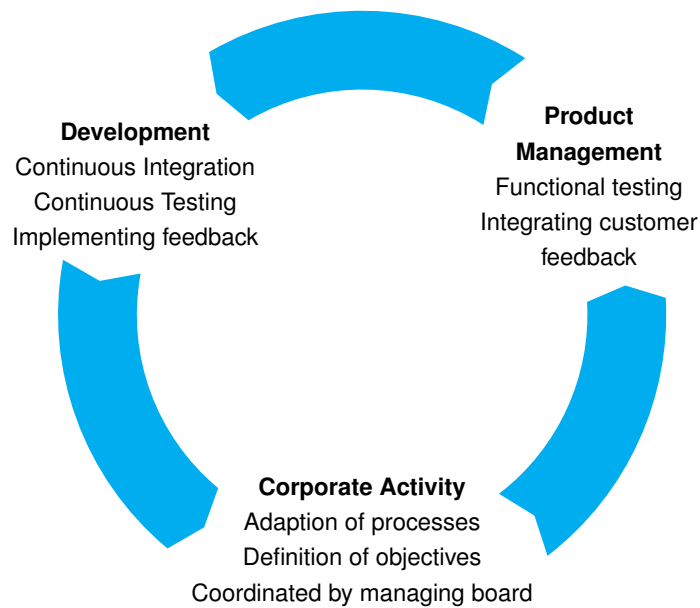

Figure 3.3: SQA Responsibilities

### 3.2.4 Software Release Procedure

The defined minimum requirements for software releases of type Hotfix, Service Pack and Major Release are illustrated by Figure 3.4. Approval of individual products is accomplished by the respective person in charge; the overall approval is in authority of the managing board executive for products.

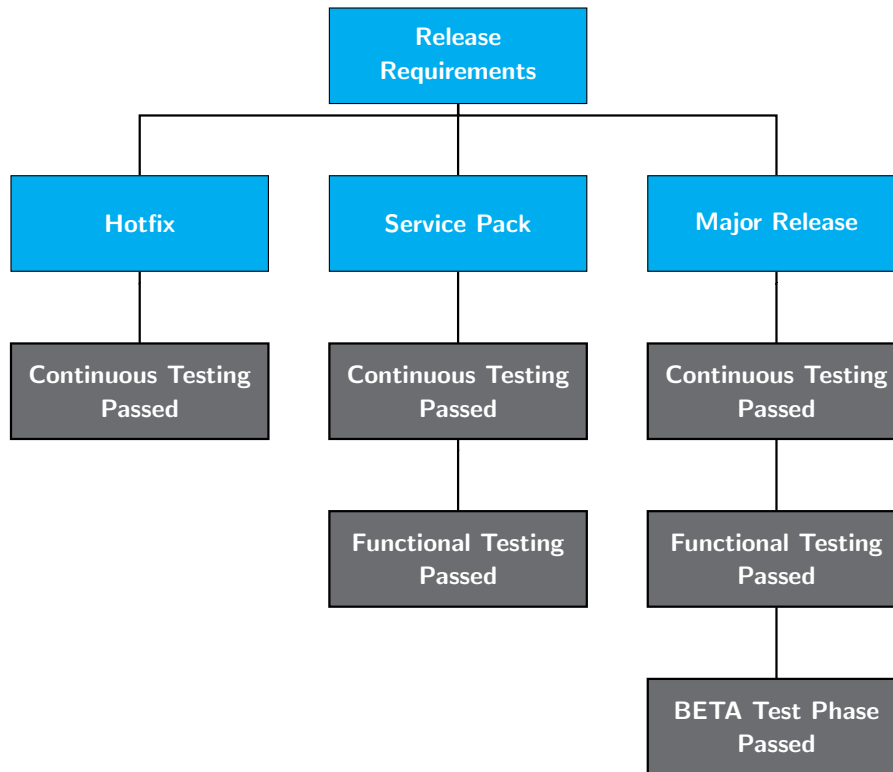

Figure 3.4: Software Release Requirements

### 3.3 Instruments

#### 3.3.1 CRM System

Each request from our customers is traced by means of a Customer Relation Management (CRM) System assuring that no case will be lost. Detailed feedback to the customer is provided via this system.

Possible bug fixes or enhancements of the software are documented with version number and date in corresponding log files. These log files are published via RSS-feed to our customers. In this way, announcement of available software updates (service-pack or hotfix) is featured proactively. Moreover, information is provided independent of and prior to the actual software update procedure.

Further sources of information are the electronic newsletter/ newsfeeds and the internet forum ([www.sofistik.de](http://www.sofistik.de) / [www.sofistik.com](http://www.sofistik.com)).

#### 3.3.2 Tracking System (internal)

For SOFiSTiK-internal management and coordination of the software development process - both regarding implementation of features and the fixing of detected bugs - a web-based tracking system is adopted.

#### 3.3.3 Continuous Integration – Continuous Testing

As mentioned above, the production chain is characterized by a high degree of automation. An important concern is the realization of prompt feedback cycles featuring an immediate response regarding quality of the current development state.



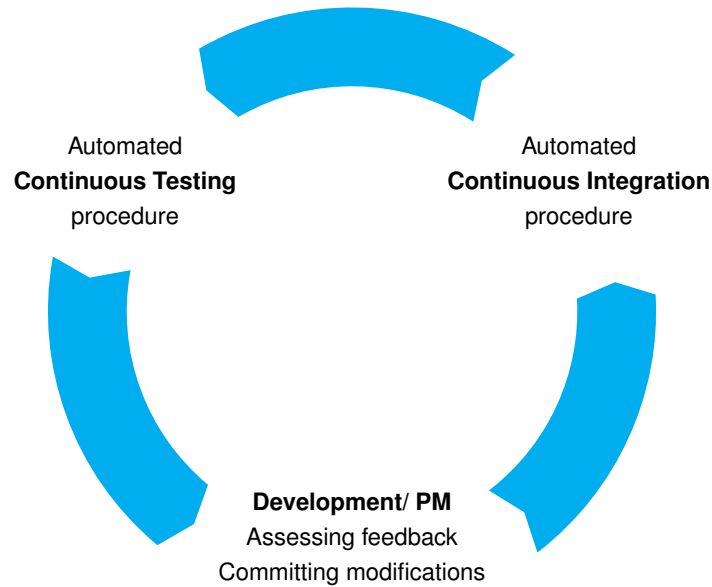

Figure 3.5: Feedback cycle: Continuous Integration – Continuous Testing

*Continuous integration* denotes the automated process, assuring that all executed and committed modifications of the program's code basis are directly integrated via rebuild into the internal testing environment.

Upon completion of the integration, the *continuous testing* procedure is triggered automatically. This procedure executes a standardized testing scenario using the newly updated software. Test results are prepared in form of compact test protocols allowing for quick assessment.

The executed tests are so-called regression tests. Regression tests examine by means of associated reference solutions whether the conducted modifications of the code basis cause undesired performance in other already tested parts of the program.

Together, continuous integration and continuous testing form the basis for a quality control that directly accompanies the development process. This way, possibly required corrections can be initiated promptly. SOFiSTiK has successfully implemented this procedure. Currently, the continuous test database comprises more than 3000 tests.

## 3.4 Additional Provisions

### 3.4.1 Training

As a special service to our customers, SOFiSTiK provides for comprehensive and individually tailored training to support a qualified and responsible use of the software. This is complemented by offering a variety of thematic workshops which are dedicated to specific engineering topics.

It is the credo of SOFiSTiK that a high-quality product can only be created and maintained by highly qualified personnel. Continuing education of the staff members is required by SOFiSTiK and it is supported by an education program which involves both in- house trainings and provisions of external trainings on a regular basis.

### 3.4.2 Academia Network

Arising questions are treated by an intense discussion with customers, authorities and scientists to find the best interpretation.

### **3.5 Disclaimer**

Despite all efforts to achieve the highest possible degree of reliability, SOFiSTiK cannot assure that the provided software is bug-free or that it will solve a particular problem in a way which is implied with the opinion of the user in all details. Engineering skill is required when assessing the software results.

## Part II

# Design Code Benchmarks



## 4 DCE-EN1: Design of Slab for Bending

### Overview

<b>Design Code Family(s):</b>	DIN
<b>Design Code(s):</b>	DIN EN 1992-1-1
<b>Module(s):</b>	AQB
<b>Input file(s):</b>	<a href="#">slab_bending.dat</a>

### 4.1 Problem Description

The problem consists of a slab section of depth  $h$ , as shown in Fig. 4.1. The cross-section is designed for an ultimate moment  $m_{Ed}$  and the required reinforcement is determined.

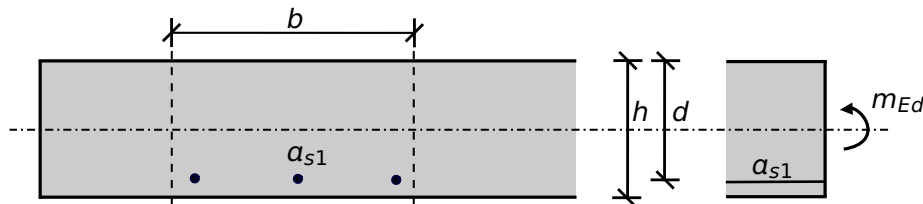

Figure 4.1: Problem Description

### 4.2 Reference Solution

This example is concerned with the design of sections for ULS, subject to pure flexure, such as beams or slabs. The content of this problem is covered by the following parts of DIN EN 1992-1-1:2004 [1]:

- Design stress-strain curves for concrete and reinforcement (Section 3.1.7, 3.2.7)
- Basic assumptions for section design (Section 6.1)
- Reinforcement (Section 9.3.1.1, 9.2.1.1)

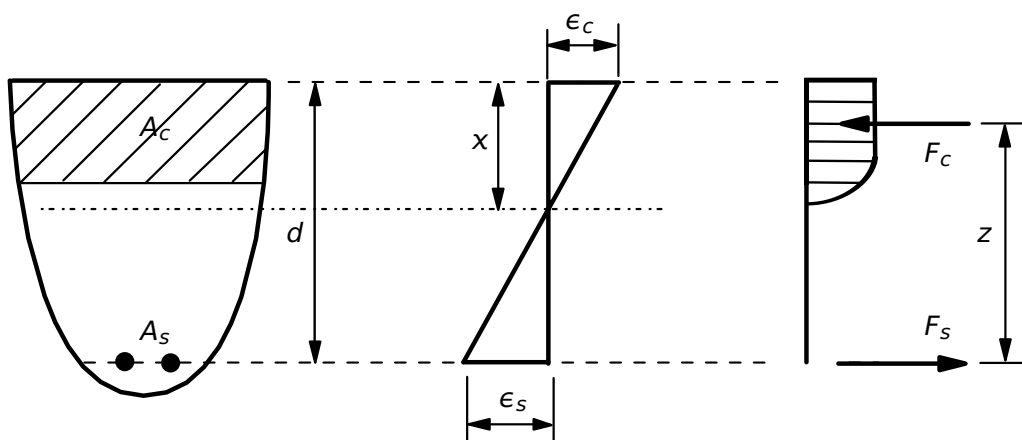

Figure 4.2: Stress and Strain Distributions in the Design of Cross-sections

In singly reinforced beams and slabs, the conditions in the cross-section at the ultimate limit state, are

assumed to be as shown in Fig. 4.2. The design stress-strain diagram for reinforcing steel considered in this example, consists of an inclined top branch, as presented in Fig. 4.3 and as defined in DIN EN 1992-1-1:2004 [1] (Section 3.2.7).

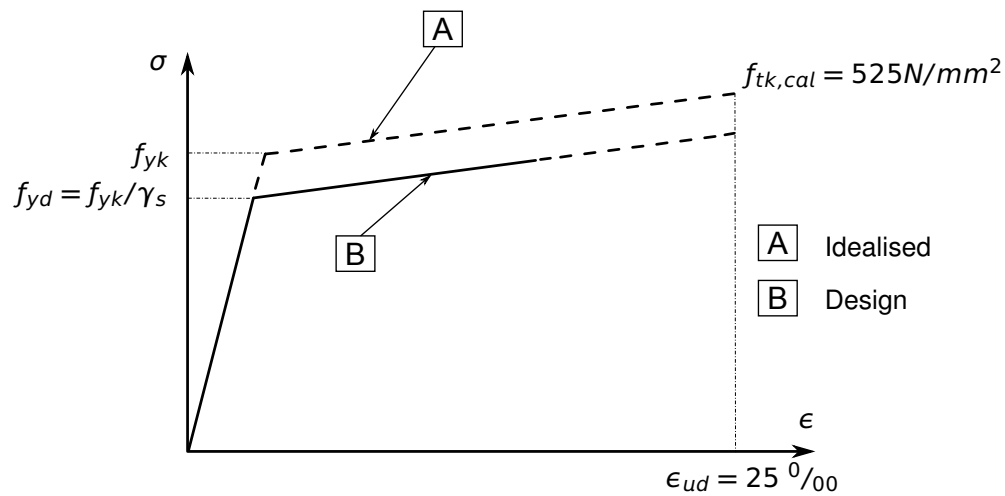

Figure 4.3: Idealised and Design Stress-Strain Diagram for Reinforcing Steel

### 4.3 Model and Results

The rectangular slab section, with properties as defined in Table 4.1, is to be designed, with respect to DIN EN 1992-1-1:2004 (German National Annex) [1] [2], to carry an ultimate moment of 25 kNm. The calculation steps with different design methods [3] [4] [5] are presented below and the results are given in Table 4.2. Here, it has to be mentioned that these standard methods employed in order to calculate the reinforcement are approximate, and therefore deviations often occur.

Table 4.1: Model Properties

Material Properties	Geometric Properties	Loading
C 25/30	$h = 20.0 \text{ cm}$	$m_{Ed} = 25 \text{ kNm/m}$
B 500A	$d = 17.0 \text{ cm}$ $b = 1.0 \text{ m}$	

Table 4.2: Results

	SOF.	General Chart [3]	$\omega$ -Table [3]	$k_d$ -Table [3]
$a_{s1} [\text{cm}^2/\text{m}]$	3.334	3.328	3.334	3.333

## 4.4 Design Process<sup>1</sup>

### Design with respect to DIN EN 1992-1-1:2004 (NA) [1] [2]:<sup>2</sup>

Material:

Concrete:  $\gamma_c = 1.50$

Steel:  $\gamma_s = 1.15$

$f_{ck} = 25 \text{ MPa}$

$f_{cd} = \alpha_{cc} \cdot f_{ck} / \gamma_c = 0.85 \cdot 25 / 1.5 = 14.17 \text{ MPa}$

$f_{yk} = 500 \text{ MPa}$

$f_{yd} = f_{yk} / \gamma_s = 500 / 1.15 = 434.78 \text{ MPa}$

Design Load:

$M_{Ed} = m_{Ed} \cdot b = 25 \text{ kNm}; \quad N_{Ed} = 0$

$M_{Eds} = M_{Ed} - N_{Ed} \cdot z_{s1} = 25 \text{ kNm}$

### Design with respect to General Design Chart Bending with axial force for rectangular cross-sections:

$$\mu_{Eds} = \frac{M_{Eds}}{b \cdot d^2 \cdot f_{cd}} = \frac{25 \cdot 10^{-3}}{1.0 \cdot 0.17^2 \cdot 14.17} = 0.061$$

$$\epsilon = 25 \cdot 10^{-3}; \quad \zeta = 0.97 \quad \rightarrow \quad \sigma_{s1d} = 456.52 \text{ MPa}$$

$$\alpha_{s1} = \frac{1}{\sigma_{s1d}} \cdot \left( \frac{M_{Eds}}{\zeta \cdot d} + N_{Ed} \right) = 3.328 \text{ cm}^2/\text{m}$$

(NDP) 2.4.2.4: (1), Tab. 2.1DE: Partial factors for materials

Tab. 3.1: Strength for concrete

3.1.6: (1)P, Eq. (3.15):  $\alpha_{cc} = 0.85$  considering long term effects

3.2.2: (3)P: yield strength  $f_{yk} = 500 \text{ MPa}$

3.2.7: (2), Fig. 3.8

Tab. 9.1 [3]: General Chart for up to C50/60 - Cross-section without compression reinforcement

### Design with respect to $\omega$ - (or $\mu_s$ - ) Design Table for rectangular cross-sections:

$$\mu_{Eds} = \frac{M_{Eds}}{b \cdot d^2 \cdot f_{cd}} = \frac{25 \cdot 10^{-3}}{1.0 \cdot 0.17^2 \cdot 14.17} = 0.061$$

$\omega = 0.0632$  (interpolated) and  $\sigma_{sd} = 456.52 \text{ MPa}$

$$\alpha_{s1} = \frac{1}{\sigma_{sd}} \cdot (\omega \cdot b \cdot d \cdot f_{cd} + N_{Ed}) = 3.334 \text{ cm}^2/\text{m}$$

Tab. 9.2 [3]:  $\omega$ -Table for up to C50/60 - Rectangular section without compression reinforcement

### Design with respect to $k_d$ - Design Table for rectangular cross-sections:

$$k_d = \frac{d}{\sqrt{M_{Eds}/b}} = \frac{17}{\sqrt{25/1.0}} = 3.40$$

$k_s = 2.381, \kappa_s = 0.952$  (interpolated values)

$$\alpha_{s1} = \left( k_s \cdot \frac{M_{Eds}}{d} + \frac{N_{Ed}}{\sigma_{s1d}} \right) \cdot \kappa_s = 3.333 \text{ cm}^2/\text{m}$$

Tab. 9.3 [3]:  $k_d$ -Table for up to C50/60 - Rectangular section without compression reinforcement

<sup>1</sup>The tools used in the design process are based on steel stress-strain diagrams, as defined in [1] 3.2.7:(2), Fig. 3.8, which can be seen in Fig. 4.3.

<sup>2</sup>The sections mentioned in the margins refer to DIN EN 1992-1-1:2004 (German National Annex) [1], [2], unless otherwise specified.

## 4.5 Conclusion

This example shows the calculation of the required reinforcement for a slab section under bending. Various different reference solutions are employed in order to compare the SOFiSTiK results to. It has been shown that the results are reproduced with excellent accuracy.

## 4.6 Literature

- [1] *DIN EN 1992-1-1/NA: Eurocode 2: Design of concrete structures, Part 1-1/NA: General rules and rules for buildings - German version EN 1992-1-1:2005 (D), Nationaler Anhang Deutschland - Stand Februar 2010.* CEN. 2010.
  - [2] F. Fingerloos, J. Hegger, and K. Zilch. *DIN EN 1992-1-1 Bemessung und Konstruktion von Stahlbeton- und Spannbetontragwerken - Teil 1-1: Allgemeine Bemessungsregeln und Regeln für den Hochbau.* BVPI, DBV, ISB, VBI. Ernst & Sohn, Beuth, 2012.
  - [3] K. Holschemacher, T. Müller, and F. Lobisch. *Bemessungshilfsmittel für Betonbauteile nach Eurocode 2 Bauingenieure.* 3rd. Ernst & Sohn, 2012.
  - [4] *Beispiele zur Bemessung nach Eurocode 2 - Band 1: Hochbau.* Ernst & Sohn. Deutschen Beton- und Bautechnik-Verein E.V. 2011.
  - [5] R. S. Narayanan and A. W. Beeby. *Designers' Guide to EN 1992-1-1 and EN 1992-1-2 - Eurocode 2: Design of Concrete Structures.* Thomas Telford, 2005.
-



## 5 DCE-EN2: Design of a Rectangular CS for Bending

### Overview

<b>Design Code Family(s):</b>	DIN
<b>Design Code(s):</b>	DIN EN 1992-1-1
<b>Module(s):</b>	AQB
<b>Input file(s):</b>	<a href="#">rectangular_bending.dat</a>

### 5.1 Problem Description

The problem consists of a rectangular section, as shown in Fig. 5.1. The cross-section is designed for an ultimate moment  $M_{Ed}$  and the required reinforcement is determined.

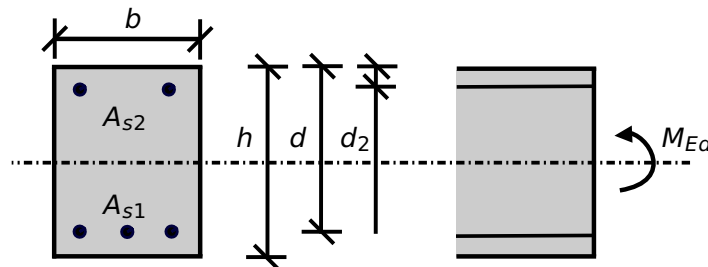

Figure 5.1: Problem Description

### 5.2 Reference Solution

This example is concerned with the design of doubly reinforced sections for ULS, subject to pure flexure, such as beams. The content of this problem is covered by the following parts of DIN EN 1992-1-1:2004 [1]:

- Design stress-strain curves for concrete and reinforcement (Section 3.1.7, 3.2.7)
- Basic assumptions for section design (Section 6.1)
- Reinforcement (Section 9.3.1.1, 9.2.1.1)

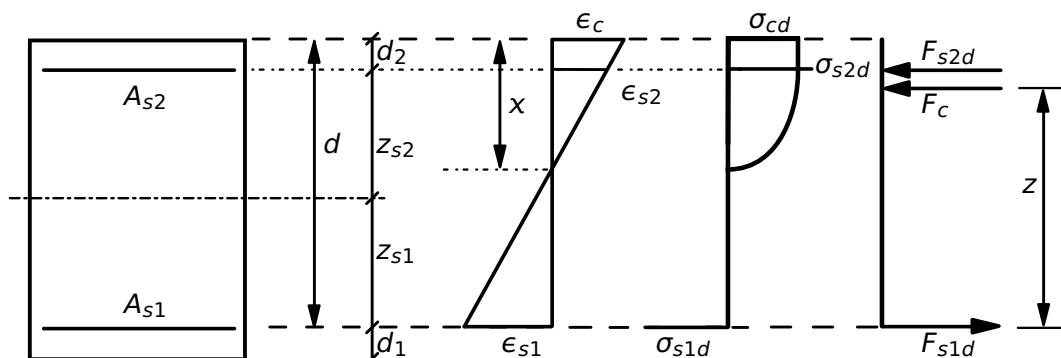

Figure 5.2: Stress and Strain Distributions in the Design of Doubly Reinforced Cross-sections

In doubly reinforced rectangular beams, the conditions in the cross-section at the ultimate limit state, are assumed to be as shown in Fig. 5.2. The design stress-strain diagram for reinforcing steel considered in this example, consists of an inclined top branch, as presented in Fig. 5.3 and as defined in DIN EN 1992-1-1:2004 [1] (Section 3.2.7).

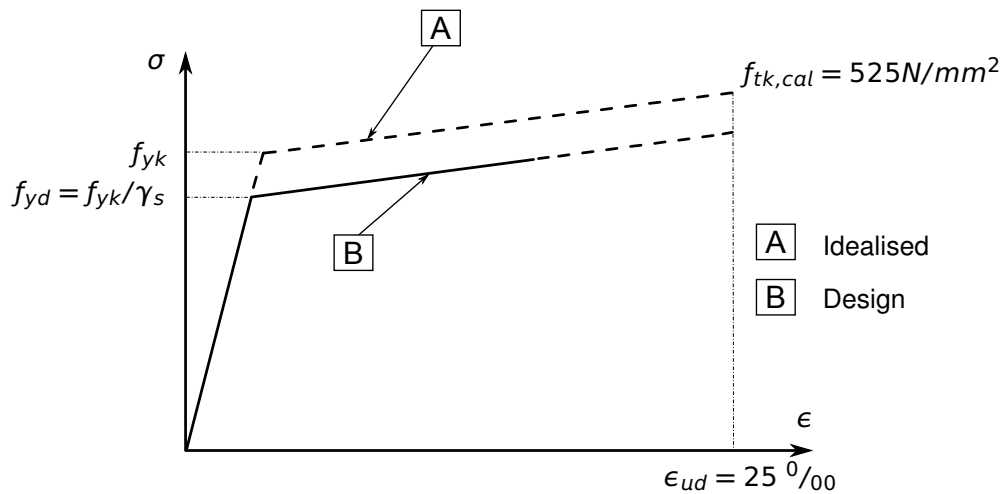

Figure 5.3: Idealised and Design Stress-Strain Diagram for Reinforcing Steel

### 5.3 Model and Results

The rectangular cross-section, with properties as defined in Table 5.1, is to be designed, with respect to DIN EN 1992-1-1:2004 (German National Annex) [1], [2], to carry an ultimate moment of 135 kNm. The calculation steps with different design methods [3] [4] [5] are presented below and the results are given in Table 5.2. Here, it has to be mentioned that these standard methods employed in order to calculate the reinforcement are approximate, and therefore deviations often occur.

Table 5.1: Model Properties

Material Properties	Geometric Properties	Loading
C 20/25	$h = 40.0 \text{ cm}$	$M_{Ed} = 135 \text{ kNm}$
B 500A	$d = 35.0 \text{ cm}$ $d_2 = 5.0 \text{ cm}$ $b = 25 \text{ cm}$	

Table 5.2: Results

	SOF.	General Chart [3]	$\omega$ —Table [3]	$k_d$ —Table [3]
$A_{s1} [\text{cm}^2/\text{m}]$	10.73	10.73	10.77	10.79
$A_{s2} [\text{cm}^2/\text{m}]$	2.47	2.47	2.52	2.43

## 5.4 Design Process<sup>1</sup>

### Design with respect to DIN EN 1992-1-1:2004 (NA) [1] [2]:<sup>2</sup>

Material:

Concrete:  $\gamma_c = 1.50$

Steel:  $\gamma_s = 1.15$

$f_{ck} = 20 \text{ MPa}$

$f_{cd} = \alpha_{cc} \cdot f_{ck} / \gamma_c = 0.85 \cdot 20 / 1.5 = 11.33 \text{ MPa}$

$f_{yk} = 500 \text{ MPa}$

$f_{yd} = f_{yk} / \gamma_s = 500 / 1.15 = 434.78 \text{ MPa}$

Design Load:

$N_{Ed} = 0$

$M_{Eds} = M_{Ed} - N_{Ed} \cdot z_{s1} = 135 \text{ kNm}$

(NDP) 2.4.2.4: (1), Tab. 2.1DE: Partial factors for materials

Tab. 3.1: Strength for concrete

3.1.6: (1)P, Eq. (3.15):  $\alpha_{cc} = 0.85$  considering long term effects

3.2.2: (3)P: yield strength  $f_{yk} = 500 \text{ MPa}$

3.2.7: (2), Fig. 3.8

### Design with respect to General Design Chart Bending with axial force for rectangular cross-sections:

$$\mu_{Eds} = \frac{M_{Eds}}{b \cdot d^2 \cdot f_{cd}} = \frac{135 \cdot 10^{-3}}{0.25 \cdot 0.35^2 \cdot 11.33} = 0.389$$

$$\mu_{Eds} > \mu_{Eds,lim} = 0.296$$

→ *compression reinforcement required*

from design chart for  $\mu_{Eds,lim} = 0.296$  and  $d_2/d = 0.143$  :

$$\epsilon_{s1} = 4.30 \cdot 10^{-3} ; \quad \epsilon_{s2} = -2.35 \cdot 10^{-3} ; \quad \zeta = z/d = 0.813$$

$$\text{for } \epsilon_{s1} = 4.30 \cdot 10^{-3} \rightarrow \sigma_{s1d} = 436.8 \text{ MPa}$$

$$\text{for } \epsilon_{s2} = -2.35 \cdot 10^{-3} \rightarrow \sigma_{s2d} = -434.9 \text{ MPa}$$

$$M_{Eds,lim} = \mu_{Eds,lim} \cdot b \cdot d^2 \cdot f_{cd} = 102.7 \text{ kNm}$$

$$\Delta M_{Eds} = M_{Eds} - M_{Eds,lim} = 135 - 102.7 = 32.3 \text{ kNm}$$

$$A_{s1} = \frac{1}{\sigma_{s1d}} \cdot \left( \frac{M_{Eds,lim}}{\zeta \cdot d} + \frac{\Delta M_{Eds}}{d - d_2} + N_{Ed} \right) = 10.73 \text{ cm}^2$$

$$A_{s2} = \frac{1}{|\sigma_{s2d}|} \cdot \frac{\Delta M_{Eds}}{d - d_2} = 2.47 \text{ cm}^2$$

5.4: (NA.5): Linear elastic analysis

$\xi$  = height of compression zone  $x/d \leq 0.45$  for C12/15 – C50/60

Tab. 9.1 [3]: General Chart for up to C50/60 - Section with compression reinforcement

### Design with respect to $\omega$ - (or $\mu_s$ - )Table for rectangular cross-sections:

$$\mu_{Eds} = \frac{M_{Eds}}{b \cdot d^2 \cdot f_{cd}} = \frac{135 \cdot 10^{-3}}{0.25 \cdot 0.35^2 \cdot 11.33} = 0.389$$

Because the internal force determination is done on the basis of a linear

<sup>1</sup>The tools used in the design process are based on steel stress-strain diagrams, as defined in [1] 3.2.7:(2), Fig. 3.8, which can be seen in Fig. 5.3.

<sup>2</sup>The sections mentioned in the margins refer to DIN EN 1992-1-1:2004 (German National Annex) [1], [2], unless otherwise specified.

5.4: (NA.5): Linear elastic analysis

$\xi$  = height of compression zone  $x/d \leq 0.45$  for C12/15 – C50/60

Tab. 9.2 [3]:  $\omega$ —Table for up to C50/60  
- Rectangular section with compression reinforcement

elastic calculation, then  $\xi_{lim} = 0.45$  is chosen. Referring to the design table with compression reinforcement and for  $d_2/d = 0.15$ :

$$\omega_1 = 0.4726; \quad \omega_2 = 0.1104$$

$$A_{s1} = \frac{1}{f_{yd}} \cdot (\omega_1 \cdot b \cdot d \cdot f_{cd} + N_{Ed}) = 10.77 \text{ cm}^2$$

$$A_{s2} = \frac{f_{cd}}{f_{yd}} \cdot (\omega_2 \cdot b \cdot d) = 2.52 \text{ cm}^2$$

**Design with respect to  $k_d$ — Design Table for rectangular cross-sections:**

$$k_d = \frac{d}{\sqrt{M_{Eds}/b}} = \frac{35}{\sqrt{135/0.25}} = 1.51$$

Tab. 9.3 [3]:  $k_d$ —Table for up to C50/60 - Rectangular section with compression reinforcement

Not able to read values from  $k_d$ —table for simply reinforced rectangular cross-sections

→ *compression reinforcement is required*

5.4: (NA.5): Linear elastic analysis  
 $\xi$  = height of compression zone  $x/d \leq 0.45$  for C12/15 – C50/60

Because the internal force determination is done on the basis of a linear elastic calculation, then  $\xi_{lim} = 0.45$  is chosen. Referring to the  $k_d$ —table with compression reinforcement:

$$k_{s1} = 2.740; \quad k_{s2} = 0.575$$

(interpolated values for  $k_d = 1.51$ )

$$\rho_1 = 1.021; \quad \rho_2 = 1.097$$

(interpolated values for  $d_2/d = 0.143$  and  $k_{s1} = 2.740$ )

$$A_{s1} = \rho_1 \cdot k_{s1} \cdot \frac{M_{Eds}}{d} + \frac{N_{Ed}}{\sigma_{s1d}} = 10.79 \text{ cm}^2$$

$$A_{s2} = \rho_2 \cdot k_{s2} \cdot \frac{M_{Eds}}{d} = 2.43 \text{ cm}^2$$

## 5.5 Conclusion

This example shows the calculation of the required reinforcement for a rectangular beam cross-section under bending. Various different reference solutions are employed in order to compare the SOFiSTiK results to. It has been shown that the results are reproduced with excellent accuracy.

## 5.6 Literature

- [1] *DIN EN 1992-1-1/NA: Eurocode 2: Design of concrete structures, Part 1-1/NA: General rules and rules for buildings - German version EN 1992-1-1:2005 (D), Nationaler Anhang Deutschland - Stand Februar 2010.* CEN. 2010.
  - [2] F. Fingerloos, J. Hegger, and K. Zilch. *DIN EN 1992-1-1 Bemessung und Konstruktion von Stahlbeton- und Spannbetontragwerken - Teil 1-1: Allgemeine Bemessungsregeln und Regeln für den Hochbau.* BVPI, DBV, ISB, VBI. Ernst & Sohn, Beuth, 2012.
  - [3] K. Holschemacher, T. Müller, and F. Lobisch. *Bemessungshilfsmittel für Betonbauteile nach Eurocode 2 Bauingenieure.* 3rd. Ernst & Sohn, 2012.
  - [4] *Beispiele zur Bemessung nach Eurocode 2 - Band 1: Hochbau.* Ernst & Sohn. Deutschen Beton- und Bautechnik-Verein E.V. 2011.
  - [5] R. S. Narayanan and A. W. Beeby. *Designers' Guide to EN 1992-1-1 and EN 1992-1-2 - Eurocode 2: Design of Concrete Structures.* Thomas Telford, 2005.
-



## 6 DCE-EN3: Design of a T-section for Bending

### Overview

<b>Design Code Family(s):</b>	DIN
<b>Design Code(s):</b>	DIN EN 1992-1-1
<b>Module(s):</b>	AQB
<b>Input file(s):</b>	<a href="#">t-beam_bending.dat</a>

### 6.1 Problem Description

The problem consists of a T-beam section, as shown in Fig. 6.1. The cross-section is designed for an ultimate moment  $M_{Ed}$  and the required reinforcement is determined.

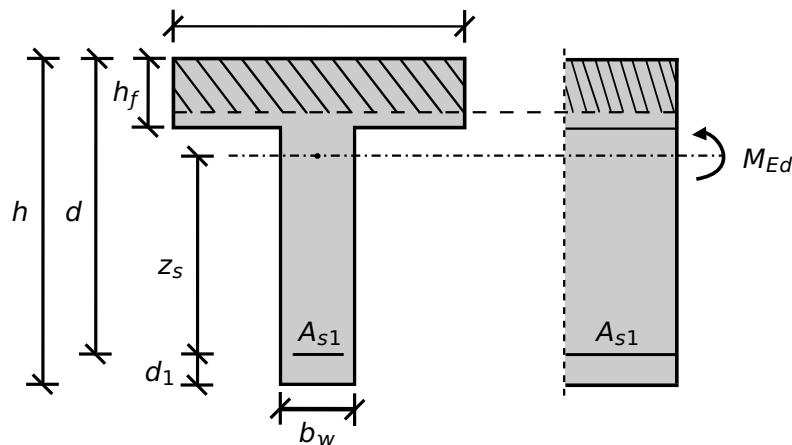

Figure 6.1: Problem Description

### 6.2 Reference Solution

This example is concerned with the design of sections for ULS, subject to pure flexure. The content of this problem is covered by the following parts of DIN EN 1992-1-1:2004 [1]:

- Design stress-strain curves for concrete and reinforcement (Section 3.1.7, 3.2.7)
- Basic assumptions for section design (Section 6.1)
- Reinforcement (Section 9.3.1.1, 9.2.1.1)

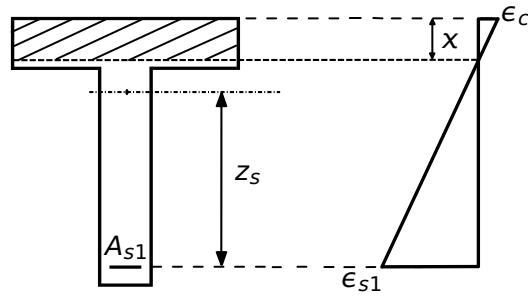

Figure 6.2: Stress and Strain Distributions in the Design of T-beams

In doubly reinforced rectangular beams, the conditions in the cross-section at the ultimate limit state, are assumed to be as shown in Fig. 6.2. The design stress-strain diagram for reinforcing steel considered in this example, consists of an inclined top branch, as presented in Fig. 6.3 and as defined in DIN EN 1992-1-1:2004 [1] (Section 3.2.7).

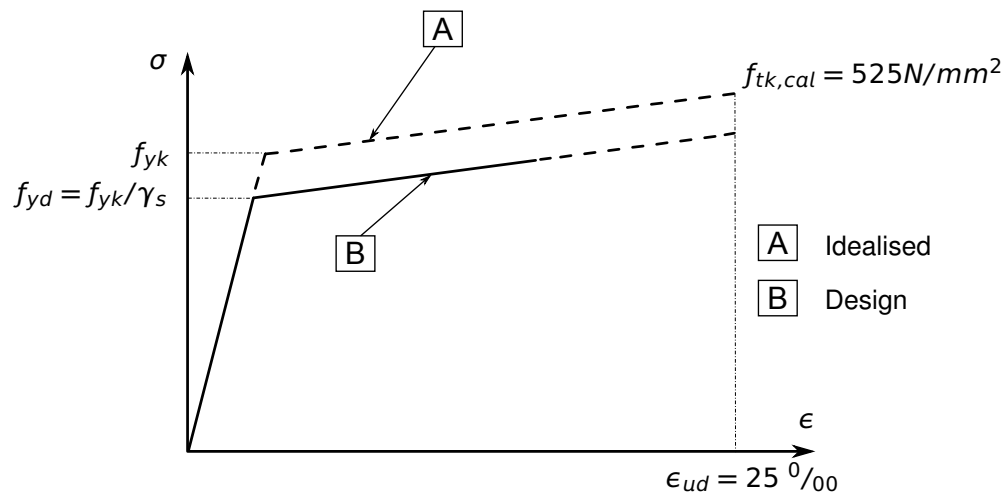

Figure 6.3: Idealised and Design Stress-Strain Diagram for Reinforcing Steel

### 6.3 Model and Results

The T-beam, with properties as defined in Table 6.1, is to be designed, with respect to DIN EN 1992-1-1:2004 (German National Annex) [1], [2], to carry an ultimate moment of 425 kNm. The calculation steps with different design methods [3] [4] [5] are presented below and the results are given in Table 6.2. Here, it has to be mentioned that these standard methods employed in order to calculate the reinforcement are approximate, and therefore deviations often occur.

Table 6.1: Model Properties

Material Properties	Geometric Properties	Loading
C 20/25	$h = 65.0 \text{ cm}$	$M_{Ed} = 425 \text{ kNm}$
B 500A	$d = 60.0 \text{ cm}$	
	$d_1 = 5.0 \text{ cm}$	
	$b = 30 \text{ cm}$	
	$b_{eff} = 258 \text{ cm}$	



Table 6.1: (continued)

Material Properties	Geometric Properties	Loading
	$h_f = 18 \text{ cm}$	

Table 6.2: Results

	SOF.	$\omega$ —Table [3]	$k_d$ —Table [3]
$A_{s1} [\text{cm}^2/\text{m}]$	15.90	15.74	15.85

## 6.4 Design Process<sup>1</sup>

### Design with respect to DIN EN 1992-1-1:2004 (NA) [1] [2]:<sup>2</sup>

Material:

(NDP) 2.4.2.4: (1), Tab. 2.1DE: Partial factors for materials

Concrete:  $\gamma_c = 1.50$

Steel:  $\gamma_s = 1.15$

Tab. 3.1: Strength for concrete

$f_{ck} = 20 \text{ MPa}$

3.1.6: (1)P, Eq. (3.15):  $\alpha_{cc} = 0.85$  considering long term effects

$f_{cd} = \alpha_{cc} \cdot f_{ck} / \gamma_c = 0.85 \cdot 20 / 1.5 = 11.33 \text{ MPa}$

3.2.2: (3)P: yield strength  $f_{yk} = 500 \text{ MPa}$

$f_{yk} = 500 \text{ MPa}$

3.2.7: (2), Fig. 3.8

$f_{yd} = f_{yk} / \gamma_s = 500 / 1.15 = 434.78 \text{ MPa}$

Design Load:

$N_{Ed} = 0$

$M_{Eds} = M_{Ed} - N_{Ed} \cdot z_{s1} = 425 \text{ kNm}$

### Design with respect to $\omega$ – (or $\mu_s$ –) Table for T-beams:

Tab. 9.4 [3]:  $\omega$ –Table for up to C50/60 - T-beam

$$\mu_{Eds} = \frac{M_{Eds}}{b_{eff} \cdot d^2 \cdot f_{cd}} = \frac{425 \cdot 10^{-3}}{2.58 \cdot 0.60^2 \cdot 11.33} = 0.040$$

Referring to the design table for T-beams for:

$\mu_{Eds} = 0.040$  and

$$\frac{h_f}{d} = \frac{0.18}{0.60} = 0.30; \quad \frac{b_{eff}}{b_w} = \frac{2.58}{0.30} = 8.6$$

$\rightarrow \omega_1 = 0.039$

$$A_{s1} = \frac{1}{f_{yd}} \cdot (\omega_1 \cdot b_{eff} \cdot d \cdot f_{cd} + N_{Ed}) = 15.74 \text{ cm}^2$$

### Design with respect to $k_d$ – Design Table for T-beams:

Alternatively, the  $k_d$ –Tables can be applied, demonstrated that the neutral line lies inside the flange.

Tab. 9.3 [3]:  $k_d$ –Table for up to C50/60 - Rectangular section without compression reinforcement

$$k_d = \frac{d}{\sqrt{M_{Eds}/b}} = \frac{60}{\sqrt{425/2.58}} = 4.67$$

Referring to the table for  $k_d = 4.67$  and after interpolation

$\rightarrow k_s = 2.351; \quad \xi = 0.060; \quad \kappa_s = 0.952$

$k_d$ –Table is applicable since the neutral line lies inside the flange

$x = \xi \cdot d = 0.060 \cdot 60 = 3.6 \text{ cm}; \quad h_f = 18 \text{ cm}$

$$A_{s1} = \left( k_s \cdot \frac{M_{Eds}}{d} + \frac{N_{Ed}}{\sigma_{s1d}} \right) \cdot \kappa_s = 15.85 \text{ cm}^2$$

<sup>1</sup>The tools used in the design process are based on steel stress-strain diagrams, as defined in [1] 3.2.7:(2), Fig. 3.8, which can be seen in Fig. 6.3.

<sup>2</sup>The sections mentioned in the margins refer to DIN EN 1992-1-1:2004 (German National Annex) [1], [2], unless otherwise specified.



## 6.5 Conclusion

This example shows the calculation of the required reinforcement for a T-beam under bending. Two different reference solutions are employed in order to compare the SOFiSTiK results to. It has been shown that the results are reproduced with excellent accuracy.

## 6.6 Literature

- [1] *DIN EN 1992-1-1/NA: Eurocode 2: Design of concrete structures, Part 1-1/NA: General rules and rules for buildings - German version EN 1992-1-1:2005 (D), Nationaler Anhang Deutschland - Stand Februar 2010.* CEN, 2010.
  - [2] F. Fingerloos, J. Hegger, and K. Zilch. *DIN EN 1992-1-1 Bemessung und Konstruktion von Stahlbeton- und Spannbetontragwerken - Teil 1-1: Allgemeine Bemessungsregeln und Regeln für den Hochbau.* BVPI, DBV, ISB, VBI. Ernst & Sohn, Beuth, 2012.
  - [3] K. Holschemacher, T. Müller, and F. Lobisch. *Bemessungshilfsmittel für Betonbauteile nach Eurocode 2 Bauingenieure.* 3rd. Ernst & Sohn, 2012.
  - [4] *Beispiele zur Bemessung nach Eurocode 2 - Band 1: Hochbau.* Ernst & Sohn. Deutschen Beton- und Bautechnik-Verein E.V. 2011.
  - [5] R. S. Narayanan and A. W. Beeby. *Designers' Guide to EN 1992-1-1 and EN 1992-1-2 - Eurocode 2: Design of Concrete Structures.* Thomas Telford, 2005.
-

## 7 DCE-EN4: Design of a Rectangular CS for Bending and Axial Force

Overview	
<b>Design Code Family(s):</b>	DIN
<b>Design Code(s):</b>	DIN EN 1992-1-1
<b>Module(s):</b>	AQB
<b>Input file(s):</b>	<a href="#">rectangular_bending_axial.dat</a>

### 7.1 Problem Description

The problem consists of a rectangular section, as shown in Fig. 7.1. The cross-section is designed for an ultimate moment  $M_{Ed}$  and a compressive force  $N_{Ed}$  and the required reinforcement is determined.

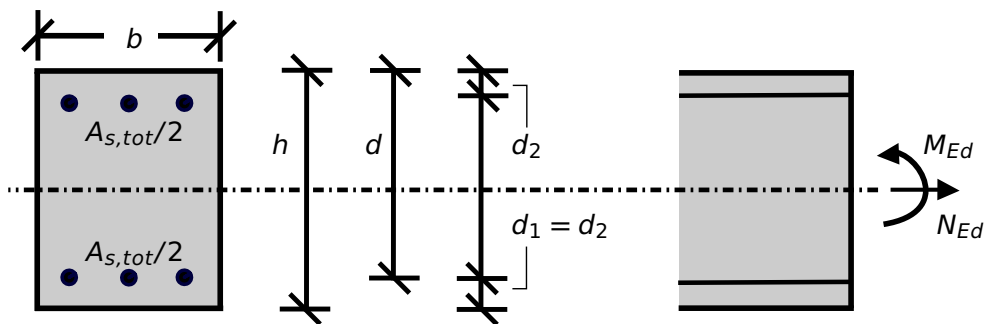

Figure 7.1: Problem Description

### 7.2 Reference Solution

This example is concerned with the design of sections for ULS, subject to bending with axial force. The content of this problem is covered by the following parts of DIN EN 1992-1-1:2004 [1]:

- Design stress-strain curves for concrete and reinforcement (Section 3.1.7, 3.2.7)
- Basic assumptions for section design (Section 6.1)
- Reinforcement (Section 9.3.1.1, 9.2.1.1)

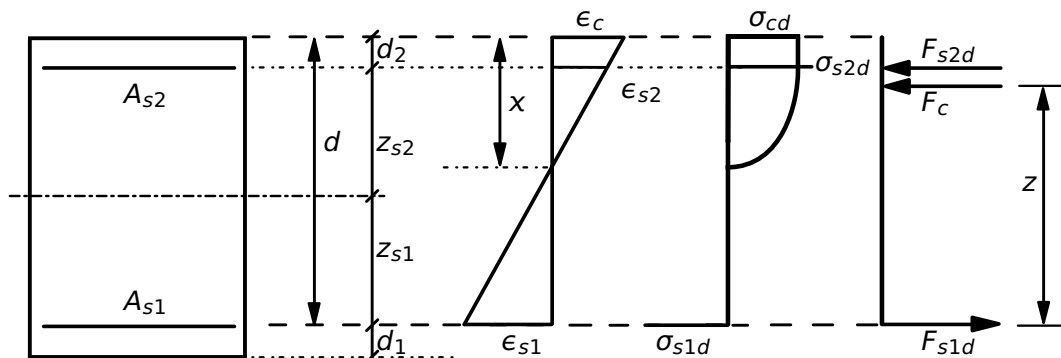

Figure 7.2: Stress and Strain Distributions in the Design of Doubly Reinforced Cross-sections

In doubly reinforced rectangular beams, the conditions in the cross-section at the ultimate limit state, are assumed to be as shown in Fig. 7.2. The design stress-strain diagram for reinforcing steel considered in this example, consists of an horizontal top branch, as presented in Fig. 7.3 and as defined in DIN EN 1992-1-1:2004 [1] (Section 3.2.7).

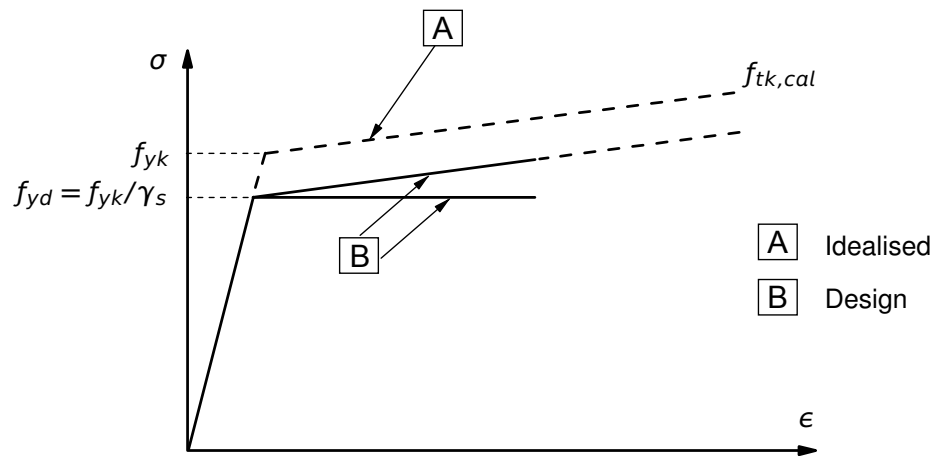

Figure 7.3: Idealised and Design Stress-Strain Diagram for Reinforcing Steel

### 7.3 Model and Results

The rectangular cross-section, with properties as defined in Table 7.1, is to be designed, with respect to DIN EN 1992-1-1:2004 (German National Annex) [1], [2], to carry an ultimate moment of 382 kNm with an axial compressive force of 1785 kN. The calculation steps with a commonly used design method [3] [4] are presented below and the results are given in Table 7.2. Here, it has to be mentioned that the standard methods employed in order to calculate the reinforcement are approximate, and therefore deviations often occur.

Table 7.1: Model Properties

Material Properties	Geometric Properties	Loading
C 30/37	$h = 50.0 \text{ cm}$	$M_{Ed} = 382 \text{ kNm}$
B 500A	$d = 45.0 \text{ cm}$ $d_1 = d_2 = 5.0 \text{ cm}$ $b = 30 \text{ cm}$	$N_{Ed} = -1785 \text{ kN}$

Table 7.2: Results

	SOF.	Interaction Diagram [3]
$A_{s,tot} [\text{cm}^2/\text{m}]$	35.03	35.19

## 7.4 Design Process<sup>1</sup>

### Design with respect to DIN EN 1992-1-1:2004 (NA) [1] [2]:<sup>2</sup>

Material:

Concrete:  $\gamma_c = 1.50$

Steel:  $\gamma_s = 1.15$

$f_{ck} = 30 \text{ MPa}$

$f_{cd} = \alpha_{cc} \cdot f_{ck} / \gamma_c = 0.85 \cdot 30 / 1.5 = 17.0 \text{ MPa}$

$f_{yk} = 500 \text{ MPa}$

$f_{yd} = f_{yk} / \gamma_s = 500 / 1.15 = 434.78 \text{ MPa}$

Design Load:

$N_{Ed} = -1785 \text{ kN}$

$M_{Ed} = 382 \text{ kNm}$

$$\frac{e_d}{h} = \left| \frac{M_{Ed}}{N_{Ed} \cdot h} \right| = \left| \frac{382}{-1785 \cdot 0.50} \right| = 0.428 < 3.5$$

→ Axial force dominant → Design with respect to  $\mu - \nu$  interaction diagram is suggested

### Design with respect to Interaction diagram for Bending with axial force for rectangular cross-sections:

$$\mu_{Ed} = \frac{M_{Ed}}{b \cdot h^2 \cdot f_{cd}} = \frac{382 \cdot 10^{-3}}{0.30 \cdot 0.50^2 \cdot 17.0} = 0.30$$

$$\nu_{Ed} = \frac{N_{Ed}}{b \cdot h^2 \cdot f_{cd}} = \frac{-1785 \cdot 10^{-3}}{0.30 \cdot 0.50 \cdot 17.0} = -0.70$$

from design chart for  $d_1/h = 0.05/0.5 = 0.10$ :

$$\omega_{tot} = 0.60$$

$$A_{s,tot} = \omega_{tot} \cdot \frac{b \cdot h}{f_{yd}/f_{cd}} = 35.19 \text{ cm}^2$$

$$A_{s1} = A_{s2} = \frac{A_{s,tot}}{2} = 17.6 \text{ cm}^2$$

(NDP) 2.4.2.4: (1), Tab. 2.1DE: Partial factors for materials

Tab. 3.1: Strength for concrete

3.1.6: (1)P, Eq. (3.15):  $\alpha_{cc} = 0.85$  considering long term effects

3.2.2: (3)P: yield strength  $f_{yk} = 500 \text{ MPa}$

3.2.7: (2), Fig. 3.8

Tab. 9.6 [3]:  $\mu - \nu$  Interaction diagram for concrete C12/15–C50/60 - Rectangular cross-section with double symmetric reinforcement.

<sup>1</sup>The tools used in the design process are based on steel stress-strain diagrams, as defined in [1] 3.2.7:(2), Fig. 3.8, which can be seen in Fig. 7.3.

<sup>2</sup>The sections mentioned in the margins refer to DIN EN 1992-1-1:2004 (German National Annex) [1], [2], unless otherwise specified.

## 7.5 Conclusion

This example shows the calculation of the required reinforcement for a rectangular beam cross-section under bending with axial force. It has been shown that the results are reproduced with excellent accuracy.

## 7.6 Literature

- [1] *DIN EN 1992-1-1/NA: Eurocode 2: Design of concrete structures, Part 1-1/NA: General rules and rules for buildings - German version EN 1992-1-1:2005 (D), Nationaler Anhang Deutschland - Stand Februar 2010.* CEN. 2010.
  - [2] F. Fingerloos, J. Hegger, and K. Zilch. *DIN EN 1992-1-1 Bemessung und Konstruktion von Stahlbeton- und Spannbetontragwerken - Teil 1-1: Allgemeine Bemessungsregeln und Regeln für den Hochbau.* BVPI, DBV, ISB, VBI. Ernst & Sohn, Beuth, 2012.
  - [3] K. Holschemacher, T. Müller, and F. Lobisch. *Bemessungshilfsmittel für Betonbauteile nach Eurocode 2 Bauingenieure.* 3rd. Ernst & Sohn, 2012.
  - [4] *Beispiele zur Bemessung nach Eurocode 2 - Band 1: Hochbau.* Ernst & Sohn. Deutschen Beton- und Bautechnik-Verein E.V. 2011.
-



## 8 DCE-EN5: Design of a Rectangular CS for Double Bending and Axial Force

### Overview

<b>Design Code Family(s):</b>	DIN
<b>Design Code(s):</b>	DIN EN 1992-1-1
<b>Module(s):</b>	AQB
<b>Input file(s):</b>	<a href="#">rectangular_double_bending_axial.dat</a>

### 8.1 Problem Description

The problem consists of a rectangular section, as shown in Fig. 8.1. The cross-section is designed for double axially bending moments  $M_{Edy}$ ,  $M_{Edz}$  and a compressive force  $N_{Ed}$ .

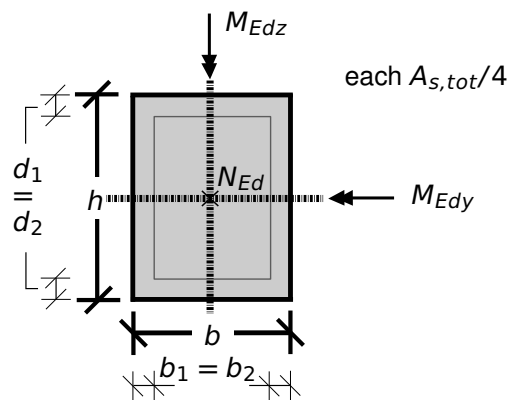

Figure 8.1: Problem Description

### 8.2 Reference Solution

This example is concerned with the design of sections for ULS, subject to double bending with axial force. The content of the problem is covered by the following parts of DIN EN 1992-1-1:2004 [1]:

- Design stress-strain curves for concrete and reinforcement (Section 3.1.7, 3.2.7)
- Basic assumptions for section design (Section 6.1)
- Reinforcement (Section 9.3.1.1, 9.2.1.1)

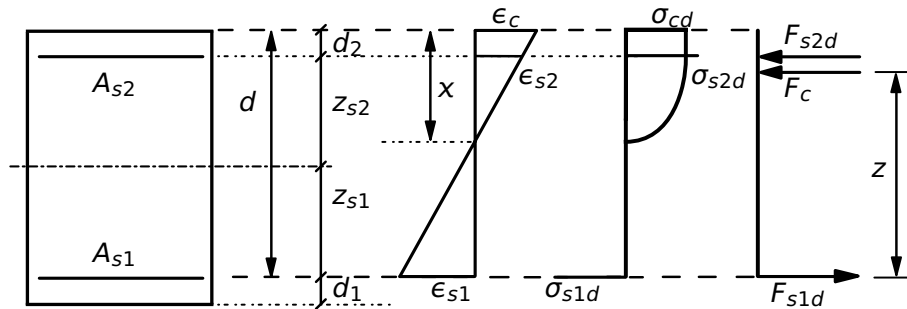

Figure 8.2: Stress and Strain Distributions in the Design of Doubly Reinforced Cross-sections

The design stress-strain diagram for reinforcing steel considered in this example, consists of an inclined top branch, as presented in Fig. 8.3 and as defined in DIN EN 1992-1-1:2004 [1] (Section 3.2.7).

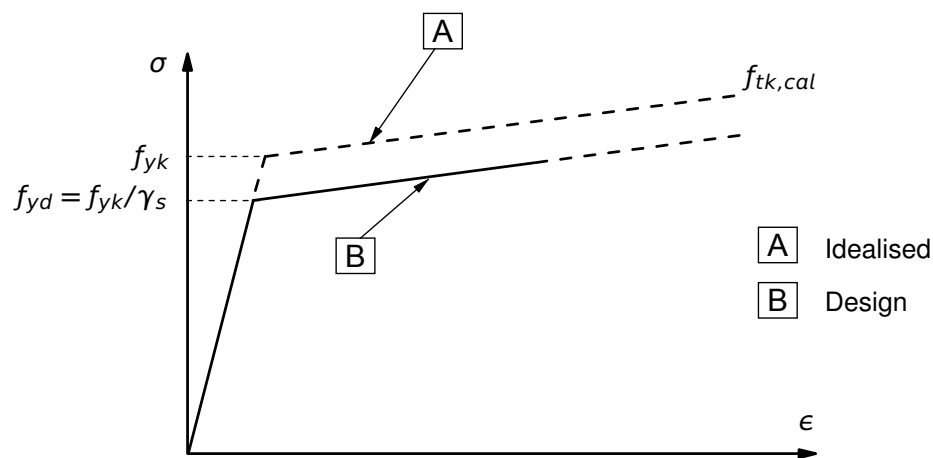

Figure 8.3: Idealised and Design Stress-Strain Diagram for Reinforcing Steel

### 8.3 Model and Results

The rectangular cross-section, with properties as defined in Table 8.1, is to be designed, with respect to DIN EN 1992-1-1:2004 (German National Annex) [1], [2], under double axial bending and an axial compressive force of 1600 kN. The calculation steps with a commonly used design method [3] [4] are presented below and the results are given in Table 8.2. Here, it has to be mentioned that the standard methods employed in order to calculate the reinforcement are approximate, and therefore deviations often occur.

Table 8.1: Model Properties

Material Properties	Geometric Properties	Loading
C 35/45	$h = 50.0 \text{ cm}$	$M_{Edy} = 500 \text{ kNm}$
B 500A	$b_1 = b_2 = 5.0 \text{ cm}$	$M_{Edz} = 450 \text{ kNm}$
	$d_1 = d_2 = 5.0 \text{ cm}$	$N_{Ed} = -1600 \text{ kN}$
	$b = 40 \text{ cm}$	

Table 8.2: Results

	SOF.	Interaction Diagram [3]
$A_{s,tot}$ [ $cm^2/m$ ]	115.9	113.1

## 8.4 Design Process<sup>1</sup>

### Design with respect to DIN EN 1992-1-1:2004 (NA) [1] [2]:<sup>2</sup>

Material:

(NDP) 2.4.2.4: (1), Tab. 2.1DE: Partial factors for materials

Concrete:  $\gamma_c = 1.50$

Steel:  $\gamma_s = 1.15$

Tab. 3.1: Strength for concrete

$f_{ck} = 30 \text{ MPa}$

3.1.6: (1)P, Eq. (3.15):  $\alpha_{cc} = 0.85$  considering long term effects

$f_{cd} = \alpha_{cc} \cdot f_{ck} / \gamma_c = 0.85 \cdot 35 / 1.5 = 19.8 \text{ MPa}$

3.2.2: (3)P: yield strength  $f_{yk} = 500 \text{ MPa}$

$f_{yk} = 500 \text{ MPa}$

3.2.7: (2), Fig. 3.8

$f_{yd} = f_{yk} / \gamma_s = 500 / 1.15 = 434.78 \text{ MPa}$

Design Load:

$N_{Ed} = -1600 \text{ kN}$

$M_{Edy} = 500 \text{ kNm}$

$M_{Edz} = 450 \text{ kNm}$

### Design with respect to Interaction diagram for Double Bending with axial force for rectangular cross-sections:

$$\mu_{Edy} = \frac{M_{Ed}}{b \cdot h^2 \cdot f_{cd}} = \frac{500 \cdot 10^{-3}}{0.40 \cdot 0.50^2 \cdot 19.8} = 0.252$$

$$\mu_{Edz} = \frac{M_{Ed}}{b \cdot h^2 \cdot f_{cd}} = \frac{450 \cdot 10^{-3}}{0.40 \cdot 0.50^2 \cdot 19.8} = 0.284$$

$$\nu_{Ed} = \frac{N_{Ed}}{b \cdot h^2 \cdot f_{cd}} = \frac{-1600 \cdot 10^{-3}}{0.40 \cdot 0.50 \cdot 19.8} = -0.403$$

Tab. 9.7 [3]:  $\mu - \nu$  Interaction diagram for concrete C12/15 – C50/60 - Rectangular cross-section with all-round symmetric reinforcement.

from design chart  $\rightarrow \omega_{tot} = 1.24$  for:

- $d_1/h = d_2/h = 0.05/0.5 = 0.10$
- $b_1/b = b_2/b = 0.05/0.4 = 0.08 \approx 0.10$
- $\nu = -0.4$
- $\mu_1 = \max[\mu_{Edy}; \mu_{Edz}] = 0.284$
- $\mu_2 = \min[\mu_{Edy}; \mu_{Edz}] = 0.252$

$$A_{s,tot} = \omega_{tot} \cdot \frac{b \cdot h}{f_{yd}/f_{cd}} = 113.1 \text{ cm}^2$$

$$A_{s,tot/4} = 28.28 \text{ cm}^2$$

<sup>1</sup>The tools used in the design process are based on steel stress-strain diagrams, as defined in [1] 3.2.7:(2), Fig. 3.8, which can be seen in Fig. 8.3.

<sup>2</sup>The sections mentioned in the margins refer to DIN EN 1992-1-1:2004 (German National Annex) [1], [2], unless otherwise specified.

## 8.5 Conclusion

This example shows the calculation of the required reinforcement for a rectangular beam cross-section under double axial bending with compressive axial force. It has been shown that the results are reproduced with excellent accuracy.

## 8.6 Literature

- [1] *DIN EN 1992-1-1/NA: Eurocode 2: Design of concrete structures, Part 1-1/NA: General rules and rules for buildings - German version EN 1992-1-1:2005 (D), Nationaler Anhang Deutschland - Stand Februar 2010.* CEN. 2010.
  - [2] F. Fingerloos, J. Hegger, and K. Zilch. *DIN EN 1992-1-1 Bemessung und Konstruktion von Stahlbeton- und Spannbetontragwerken - Teil 1-1: Allgemeine Bemessungsregeln und Regeln für den Hochbau.* BVPI, DBV, ISB, VBI. Ernst & Sohn, Beuth, 2012.
  - [3] K. Holschemacher, T. Müller, and F. Lobisch. *Bemessungshilfsmittel für Betonbauteile nach Eurocode 2 Bauingenieure.* 3rd. Ernst & Sohn, 2012.
  - [4] *Beispiele zur Bemessung nach Eurocode 2 - Band 1: Hochbau.* Ernst & Sohn. Deutschen Beton- und Bautechnik-Verein E.V. 2011.
-



## 9 DCE-EN6: Design of a Rectangular CS for Shear Force

### Overview

<b>Design Code Family(s):</b>	EN, DIN
<b>Design Code(s):</b>	DIN EN 1992-1-1, EN 1992-1-1
<b>Module(s):</b>	AQB
<b>Input file(s):</b>	<a href="#">rectangular_shear.dat</a>

### 9.1 Problem Description

The problem consists of a rectangular section, symmetrically reinforced for bending, as shown in Fig. 9.1. The cross-section is designed for shear force  $V_{Ed}$  and the required shear reinforcement is determined.

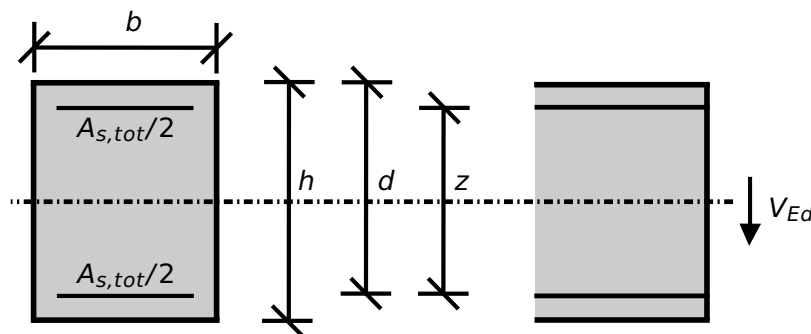

Figure 9.1: Problem Description

### 9.2 Reference Solution

This example is concerned with the design of sections for ULS, subject to shear force. The content of this problem is covered by the following parts of DIN EN 1992-1-1:2004 [1] [2]:

- Design stress-strain curves for concrete and reinforcement (Section 3.1.7, 3.2.7)
- Guidelines for shear design (Section 6.2)
- Reinforcement (Section 9.2.2)

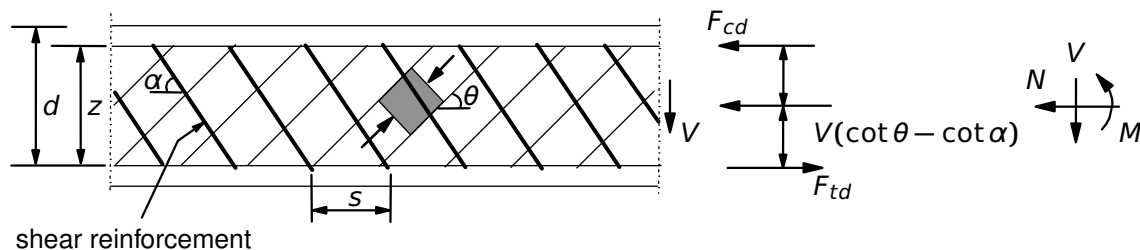

Figure 9.2: Shear Reinforced Members

The design stress-strain diagram for reinforcing steel considered in this example, consists of an inclined top branch, as presented in Fig. 9.3 and as defined in DIN EN 1992-1-1:2004 [1] (Section 3.2.7).

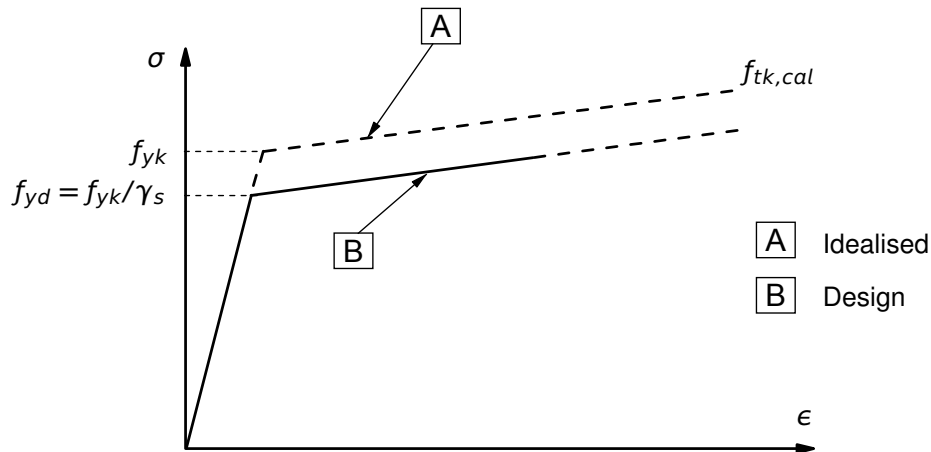

Figure 9.3: Idealised and Design Stress-Strain Diagram for Reinforcing Steel

### 9.3 Model and Results

The rectangular section, with properties as defined in Table 9.1, is to be designed, with respect to DIN EN 1992-1-1:2004 (German National Annex) [1], [2], under shear force of 343.25 kN. The reference calculation steps are presented below and the results are given in Table 9.2. Then, the same section is designed with respect to EN 1992-1-1:2004 [6]. The same angle  $\theta (= 1.60)$  is chosen, as calculated with respect to DIN EN 1992-1-1:2004, in order to compare the results. If no  $\theta$  value is input, then the calculation starts with the upper limit  $\cot \theta = 2.5$  and through an optimization process the right angle is selected. In this case, the reinforcement is determined with  $\cot \theta = 2.5$ , giving a shear reinforcement of  $7.80 \text{ cm}^2/\text{m}$ . Also in order to demonstrate that the correct value of  $V_{Rd,max} = 734.4 \text{ kN}$  (reference value) with respect to DIN EN 1992-1-1:2004 is calculated in SOFiSTiK, we input a design shear force of 734.3 delivering a shear reinforcement, but when a value of 734.4 is input then AQB gives the warning of 'no shear design possible' showing that the maximum shear resistance is exceeded.

Table 9.1: Model Properties

Material Properties	Geometric Properties	Loading
C 30/37	$h = 50.0 \text{ cm}$	$V_{Ed} = 343.25 \text{ kN}$
B 500A	$b = 30 \text{ cm}$ $d = 45.0 \text{ cm}$ $A_{s,tot} = 38.67 \text{ cm}^2$	

Table 9.2: Results

$A_{s,tot} [\text{cm}^2/\text{m}]$	Design Code	SOF.	Ref.
	DIN EN [1]	12.84	12.84
	EN [6]	12.18	12.18



## 9.4 Design Process<sup>1</sup>

Material:

Concrete:  $\gamma_c = 1.50$

(NDP) 2.4.2.4: (1), Tab. 2.1DE: Partial factors for materials

Steel:  $\gamma_s = 1.15$

$f_{ck} = 30 \text{ MPa}$

$f_{cd} = a_{cc} \cdot f_{ck} / \gamma_c = 0.85 \cdot 30 / 1.5 = 17.0 \text{ MPa}$

Tab. 3.1: Strength for concrete

3.1.6: (1)P, Eq. (3.15):  $a_{cc} = 0.85$  considering long term effects

3.2.2: (3)P: yield strength  $f_{yk} = 500 \text{ MPa}$

3.2.7: (2), Fig. 3.8

$f_{yk} = 500 \text{ MPa}$

$f_{yd} = f_{yk} / \gamma_s = 500 / 1.15 = 434.78 \text{ MPa}$

Design Load:  $V_{Ed} = 343.25 \text{ kN}$

**Design with respect to DIN EN 1992-1-1:2004 (NA) [1] [2]:<sup>2</sup>**

$z = \max \{ d - c_{v,l} - 30 \text{ mm}; d - 2 c_{v,l} \}$

(NDP) 6.2.3 (1): Inner lever arm  $z$

$c_{v,l} = SU - D/2 = 50 - 28/2 = 36 \text{ mm}$

$z = \max \{ 450 - 36 - 30 \text{ mm}; 450 - 2 \cdot 36 \}$

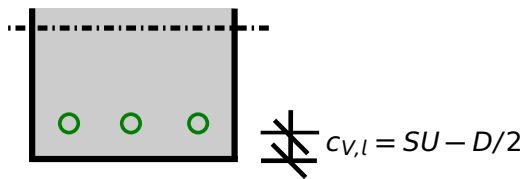

$z = \max \{ 384; 378 \} = 384 \text{ mm}$

$1.0 \leq \cot \theta \leq \frac{1.2 + 1.4 \sigma_{cd} / f_{cd}}{1 - V_{Rd,cc} / V_{Ed}} \leq 3.0$

(NDP) 6.2.3 (2): Eq. 6.7aDE

$V_{Rd,cc} = c \cdot 0.48 \cdot f_{ck}^{1/3} \cdot \left( 1 - 1.2 \frac{\sigma_{cd}}{f_{cd}} \right) \cdot b_w \cdot z$

(NDP) Eq. 6.2.3 (2): 6.7bDE  
 $c = 0.5$

$V_{Rd,cc} = 0.5 \cdot 0.48 \cdot 30^{1/3} \cdot (1 - 0) \cdot 0.3 \cdot 0.384$

(NDP) 6.2.3 (2):  $\sigma_{cd} = N_{Ed} / A_c$

$V_{Rd,cc} = 0.08591 \text{ MN} = 85.91 \text{ kN}$

$\cot \theta = \frac{1.2 + 0}{1 - 85.91 / 343.25} = 1.60$

(NDP) 6.2.3 (2): The angle  $\theta$  should be limited by Eq. 6.7DE

$A_{sw,requ} / s = V_{Ed} / (f_{ywd} \cdot z \cdot \cot \theta) = 12.84 \text{ cm}^2/\text{m}$

6.2.3 (3): Eq. 6.8

$f_{ywd} = f_{yk} / \gamma_s = 435 \text{ MPa}$

Calculating the max. shear force  $V_{Rd,max}$  in general that the concrete can bear  $\rightarrow \cot \theta = \tan \theta = 1.0$ .

$V_{Rd,max} = b_w \cdot z \cdot v_1 \cdot f_{cd} / (\cot \theta + \tan \theta)$

(NDP) 6.2.3 (3): Eq. 6.9

Maximum shear force  $V_{Rd,max}$  occurs for  $\theta = 45^\circ$ :  $\cot \theta = \tan \theta = 1$

$v_1 = 0.75 \cdot v_2 = 0.75$ ,  $v_2 = 1$  for  $\leq C50/60$

<sup>1</sup>The tools used in the design process are based on steel stress-strain diagrams, as defined in [1] 3.2.7:(2), Fig. 3.8, which can be seen in Fig. 9.3.

<sup>2</sup>The sections mentioned in the margins refer to DIN EN 1992-1-1:2004 (German National Annex) [1], [2], unless otherwise specified.

$$V_{Rd,max} = 0.3 \cdot 0.384 \cdot 0.75 \cdot 17 / (1 + 1) = 734.4 \text{ kN}$$

**Design with respect to EN 1992-1-1:2004 [6]:**<sup>3</sup>6.2.3 (1): Inner lever arm  $z$ 

$$z = 0.9 \cdot d$$

$$z = 0.9 \cdot 450 = 405 \text{ mm}$$

6.2.3 (2): Eq. 6.7N

The angle  $\theta$  should be limited by Eq. 6.7N

$$1.0 \leq \cot \theta \leq 2.5 \rightarrow \cot \theta = 1.60 \text{ (choose for comparison)}$$

$$A_{sw,requ} / s = V_{Ed} / (f_{ywd} \cdot z \cdot \cot \theta) = 12.18 \text{ cm}^2/\text{m}$$

<sup>3</sup>The sections mentioned in the margins refer to EN 1992-1-1:2004 [6], unless otherwise specified.

## 9.5 Conclusion

This example shows the calculation of the required reinforcement for a rectangular cross-section under shear force. It has been shown that the results are reproduced with excellent accuracy.

## 9.6 Literature

- [1] *DIN EN 1992-1-1/NA: Eurocode 2: Design of concrete structures, Part 1-1/NA: General rules and rules for buildings - German version EN 1992-1-1:2005 (D), Nationaler Anhang Deutschland - Stand Februar 2010.* CEN. 2010.
  - [2] F. Fingerloos, J. Hegger, and K. Zilch. *DIN EN 1992-1-1 Bemessung und Konstruktion von Stahlbeton- und Spannbetontragwerken - Teil 1-1: Allgemeine Bemessungsregeln und Regeln für den Hochbau.* BVPI, DBV, ISB, VBI. Ernst & Sohn, Beuth, 2012.
  - [6] *EN 1992-1-1: Eurocode 2: Design of concrete structures, Part 1-1: General rules and rules for buildings.* CEN. 2004.
-



## 10 DCE-EN7: Design of a T-section for Shear

### Overview

<b>Design Code Family(s):</b>	EN
<b>Design Code(s):</b>	EN 1992-1-1
<b>Module(s):</b>	AQB
<b>Input file(s):</b>	<a href="#">t-beam_shear.dat</a>

### 10.1 Problem Description

The problem consists of a T-section, as shown in Fig. 10.1. The cross-section is designed for an ultimate shear force  $V_{Ed}$  and the required reinforcement is determined.

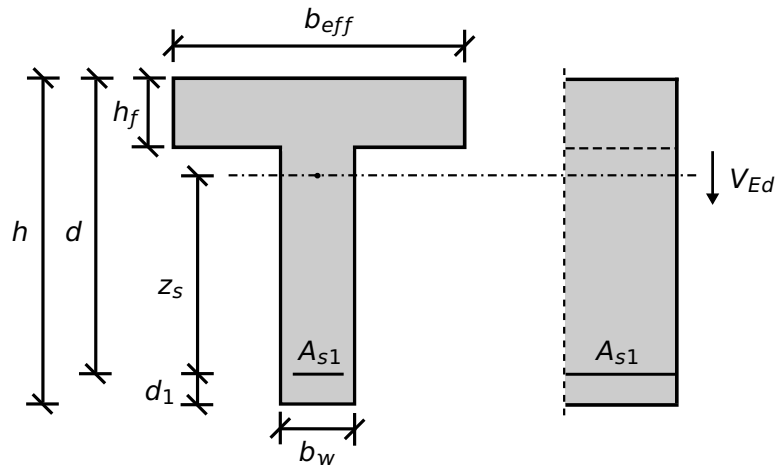

Figure 10.1: Problem Description

### 10.2 Reference Solution

This example is concerned with the design of sections for ULS, subject to shear force. The content of this problem is covered by the following parts of EN 1992-1-1:2004 [6]:

- Design stress-strain curves for concrete and reinforcement (Section 3.1.7, 3.2.7)
- Guidelines for shear design (Section 6.2)
- Reinforcement (Section 9.2.2)

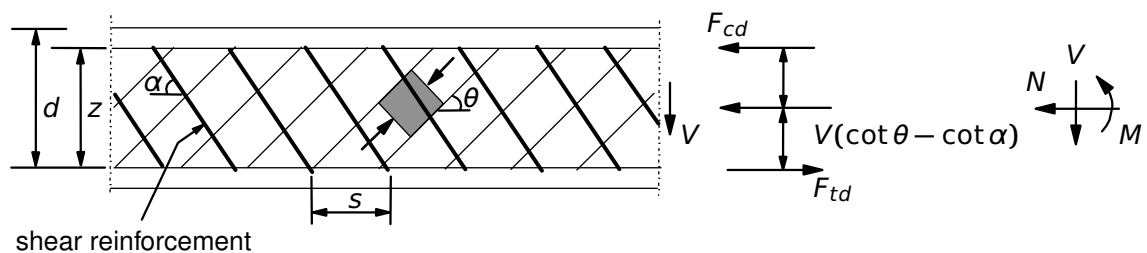

Figure 10.2: Shear Reinforced Members

The design stress-strain diagram for reinforcing steel considered in this example, consists of an inclined top branch, as presented in Fig. 10.3 and as defined in EN 1992-1-1:2004 [6] (Section 3.2.7).

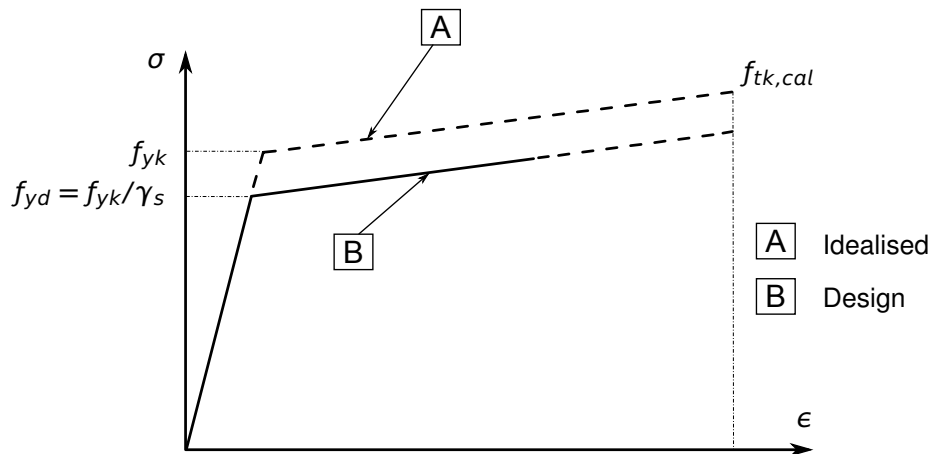

Figure 10.3: Idealised and Design Stress-Strain Diagram for Reinforcing Steel

### 10.3 Model and Results

The T-section, with properties as defined in Table 10.1, is to be designed, with respect to EN 1992-1-1:2004 [6] to carry an ultimate shear force of 450 kN. The reference calculation steps are presented below and the results are given in Table 10.2.

Table 10.1: Model Properties

Material Properties	Geometric Properties	Loading
C 30/37	$h = 60.0 \text{ cm}$	$V_{Ed} = 450 \text{ kN}$
B 500A	$d = 53.0 \text{ cm}$	
	$d_1 = 7.0 \text{ cm}$	
	$b = 30 \text{ cm}$	
	$b_{eff} = 180 \text{ cm}$	
	$h_f = 15 \text{ cm}$	
	$A_{s1} = 15 \text{ cm}^2$	

The intermediate steps of calculating the required reinforcement are also validated in this example. First we calculate the design value for the shear resistance  $V_{Rd,c}$  for members not requiring shear reinforcement.

It gives a value of  $V_{Rd,c} = 62.52 \text{ kN}$ .

Checking the results in **AQB**, we can see that SOFiSTiK outputs also  $V_{rd1,c} = 62.52 \text{ kN}$ .

Just to test this result, if we input a shear force of  $V_{Ed} = 62.51 \text{ kN}$  just below the value for  $V_{Rd,c}$ , **AQB** will not output any value for  $\cot \theta$  and the minimum reinforcement will be printed ( $M$ ). If we now give a value of  $V_{Ed} = 62.53 \text{ kN}$  just larger than  $V_{Rd,c}$ , then **AQB** will start increasing  $\cot \theta$  and the minimum

reinforcement will be printed. If we continue increasing  $V_{Ed}$ , **AQB** will continue increasing  $\cot \theta$  until it reaches the upper limit of  $\cot \theta = 2.5$  with using the minimum reinforcement. If now the minimum reinforcement is exceeded, **AQB** starts calculating a value for the required reinforcement.

Another option to test this limit of  $V_{Rd,c} = 62.52 \text{ kN}$ , would be to keep  $\cot \theta = 1.0$  and now with  $V_{Ed} = 62.53 \text{ kN}$ , **AQB** calculates a value for the required reinforcement larger than the minimum reinforcement. For the maximum value of the angle  $\theta$ , hence  $\cot \theta = 1.0$ , the maximum value allowed for  $V_{Ed}$  can be calculated as  $755.57 \text{ kN}$ . This can be found in **AQB** results as the  $V_{rd2,c} = 755.57 \text{ kN}$  for the case of  $\cot \theta = 1.0$ . Giving as an input a shear force just above this value  $V_{Ed} = 755.58$  triggers a warning "Shear design not possible".

Next step is the validation of  $V_{Rd,max}$ . When the design shear force  $V_{Ed}$  exceeds  $V_{Rd,max}$  then  $\cot \theta$  must be decreased so that  $V_{Ed} = V_{Rd,max}$ . The reference result for  $V_{Rd,max}$  is  $521.08 \text{ kN}$ . Inputting a value just below that, should give a  $\cot \theta = 2.5$ , whereas for a value just above should give  $\cot \theta < 2.5$ . This can be verified easily in **AQB** output for  $V_{Ed} = 521.07$  and  $521.09 \text{ kN}$ , respectively.

Also the minimum reinforcement is calculated exactly by **AQB** with a value of  $2.63 \text{ cm}^2/\text{m}$ .

Table 10.2: Results

	SOF.	Ref.
$A_{sw,requ} / s \text{ [cm}^2/\text{m]}$	8.68	8.679
$A_{sw,min} / s \text{ [cm}^2/\text{m]}$	2.63	2.629
$V_{Rd,c} \text{ [kN]}$	62.52	62.517
$V_{Rd,max} \text{ [kN]}$	521.08	521.08
$V_{Ed,max} \text{ [kN]}$	755.57	755.5

## 10.4 Design Process<sup>1</sup>

(NDP) 2.4.2.4: (1), Tab. 2.1DE: Partial factors for materials

Material: Concrete:  $\gamma_c = 1.50$

Steel:  $\gamma_s = 1.15$

Tab. 3.1: Strength for concrete

$$f_{ck} = 30 \text{ MPa}$$

$$f_{cd} = \alpha_{cc} \cdot f_{ck} / \gamma_c = 1.0 \cdot 30 / 1.5 = 20.0 \text{ MPa}$$

3.1.6: (1)P, Eq. (3.15):  $\alpha_{cc} = 0.85$  considering long term effects

$$\alpha_{cc} = 1.0$$

3.2.2: (3)P: yield strength  $f_{yk} = 500 \text{ MPa}$

$$f_{yk} = 500 \text{ MPa}$$

3.2.7: (2), Fig. 3.8

$$f_{yd} = f_{yk} / \gamma_s = 500 / 1.15 = 434.78 \text{ MPa}$$

Design Load:  $V_{Ed} = 450.0 \text{ kN}$

### Design with respect to EN 1992-1-1:2004 [6]:<sup>2</sup>

6.2.3 (1): Inner lever arm  $z$

$$z \approx 0.9 \cdot d = 0.9 \cdot 530 = 477 \text{ mm}$$

6.2.3 (1): Design value for shear resistance  $V_{Rd,c}$  for members not requiring design shear reinforcement

$$V_{Rd,c} = \left[ C_{Rd,c} \cdot k \cdot (100 \cdot \rho_1 \cdot f_{ck})^{1/3} + k_1 \cdot \sigma_{cp} \right] \cdot b_w \cdot d$$

$$C_{Rd,c} = 0.18 / \gamma_c = 0.12$$

$$k = 1 + \sqrt{\frac{200}{d}} = 1.6143 < 2.0$$

$$\rho_1 = \frac{A_{sl}}{b_w d} = 0.00 < 0.02$$

$$V_{Rd,c} = \left[ 0.12 \cdot 1.6143 \cdot (100 \cdot 0.0 \cdot 30)^{1/3} + 0 \right] \cdot 0.3 \cdot 0.53$$

$$V_{Rd,c} = 0.00 \text{ kN} \geq V_{Rd,c,min}$$

$$V_{Rd,c,min} = (v_{min} + k_1 \cdot \sigma_{cp}) \cdot b_w \cdot d$$

$$v_{min} = 0.035 \cdot k^{3/2} \cdot f_{ck}^{1/2}$$

$$v_{min} = 0.035 \cdot 1.6143 \cdot 30^{1/2} = 0.39319$$

$$V_{Rd,c,min} = (0.39319 + 0.0) \cdot 0.3 \cdot 0.53 = 0.062517 \text{ MN}$$

$$V_{Rd,c,min} = 62.517 \text{ kN} \rightarrow V_{Rd,c} = 62.517 \text{ kN}$$

$V_{Ed} > V_{Rd,c} \rightarrow$  shear reinforcement is required

6.2.3 (2): Eq. 6.7N: The angle  $\theta$  should be limited by Eq. 6.7N

$$1.0 \leq \cot \theta \leq 2.5 \rightarrow \text{start with } \cot \theta = 2.50$$

6.2.3 (3): Eq. 6.9

$$V_{Rd,max} = b_w \cdot z \cdot v \cdot f_{cd} / (\cot \theta + \tan \theta)$$

6.2.2 (6): Eq. 6.6N

$$v = 0.6 \cdot \left[ 1 - \frac{f_{ck}}{250} \right] = 0.528$$

Min. reinforcement:

<sup>1</sup>The tools used in the design process are based on steel stress-strain diagrams, as defined in [6] 3.2.7:(2), Fig. 3.8, which can be seen in Fig. 10.3.

<sup>2</sup>The sections mentioned in the margins refer to EN 1992-1-1:2004 [6], unless otherwise specified.



$$\rho_{w,min} = 0.08 \cdot \sqrt{f_{ck}/f_{yk}} = 0.08 \cdot \sqrt{30}/500 = 0.0008763$$

9.2.2 (5): Eq. 9.5N

$$A_{sw,min}/s = \rho_{w,min} \cdot b_w \sin \alpha$$

$$A_{sw,min}/s = 0.0008763 \cdot 30 \cdot 100 = 2.629 \text{ cm}^2/\text{m}'$$

Required reinforcement:

$$A_{sw,requ} / s = \frac{V_{Ed}}{f_{ywd} \cdot z \cdot \cot \theta}$$

6.2.3 (3): Eq. 6.8

- For  $V_{Ed} < V_{Rd,c}$

Shear reinforcement not required (min. reinforcement). In this example min. reinforcement is disabled.

$$\cot \theta = \tan \theta = 1.0, \quad b_w = 0.3 \text{ m}, \quad z = 0.477 \text{ m}, \quad \nu_1 = 0.6$$

$$\alpha_w = 1.0$$

$$V_{Rd,max} = 1.0 \cdot 0.3 \cdot 0.477 \cdot 0.60 \cdot \frac{20}{1.0 + 1.0} = 0.85859 \text{ MN}$$

$$V_{Rd,max} = 858.59 \text{ kN}$$

- For  $V_{Ed} = 63.0 \text{ kN} > V_{Rd,c} = 62.57$ :

Calculating the  $V_{Rd,max}$  value:

$$V_{Rd,max} = 0.3 \cdot 0.477 \cdot 0.528 \cdot \frac{20}{2.5 + 0.4} = 0.52108 \text{ MN}$$

$$V_{Rd,max} = 521.08 \text{ kN} \geq V_{Ed} = 63 \text{ kN}$$

Calculating the  $A_{sw,requ} / s$  value:

$$A_{sw,requ} / s = \frac{0.063}{434.78 \cdot 0.477 \cdot 2.5} \cdot 100^2 = 1.2151 \text{ cm}^2$$

- For  $V_{Ed} = 63 \text{ kN}$  and  $\cot \theta = 1.0$ :

$$V_{Ed} = 63 \text{ kN} > V_{Rd,c} = 62.51 \text{ kN}$$

Calculating the  $V_{Rd,max}$  value:

$$V_{Rd,max} = 0.3 \cdot 0.477 \cdot 0.528 \cdot \frac{20}{1.0 + 1.0} = 0.7555 \text{ MN}$$

$$V_{Rd,max} = 755.5 \text{ kN} \geq V_{Ed} = 63 \text{ kN}$$

Calculating the  $A_{sw,requ} / s$  value:

$$A_{sw,requ} / s = \frac{0.521}{434.78 \cdot 0.477 \cdot 1.0} \cdot 100^2 = 3.037 \text{ cm}^2$$

- For  $V_{Ed} = 756 \text{ kN}$  and  $\cot \theta = 1.0$ :

$$V_{Ed} = 756 \text{ kN} > V_{Rd,c} = 62.51 \text{ kN}$$

$$V_{Ed} = 756 \text{ kN} > V_{Rd,max} = 755.5 \text{ kN}$$

Shear design not possible, because the  $\cot \theta$  value is fixed and can't

be iterated.

- For  $V_{Ed} = 521.10 \text{ kN}$ :

$$V_{Ed} = 521.10 \text{ kN} > V_{Rd,c} = 62.51 \text{ kN}$$

$$V_{Ed} = 521.10 \text{ kN} > V_{Rd,max} = 521.08 \text{ kN}$$

The  $\cot \theta$  value is iterated until  $V_{Rd,max} \geq V_{Ed}$

- For  $V_{Ed} = 450 \text{ kN}$ :

$$V_{Ed} = 450 \text{ kN} > V_{Rd,c} = 62.51 \text{ kN}$$

$$V_{Ed} = 450 \text{ kN} < V_{Rd,max} = 521.08 \text{ kN}$$

Calculating the  $V_{Rd,max}$  value:

$$V_{Rd,max} = 0.3 \cdot 0.477 \cdot 0.528 \cdot \frac{20}{2.5 + 0.4} = 0.52108 \text{ MN}$$

$$V_{Rd,max} = 521.08 \text{ kN} \geq V_{Ed} = 450 \text{ kN}$$

Calculating the  $A_{sw,requ} / s$  value:

$$A_{sw,requ} / s = \frac{0.450}{434.78 \cdot 0.477 \cdot 2.5} \cdot 100^2 = 8.679 \text{ cm}^2$$

## 10.5 Conclusion

This example shows the calculation of the required reinforcement for a T-beam under shear force. It has been shown that the results are reproduced with excellent accuracy.

## 10.6 Literature

- [6] *EN 1992-1-1: Eurocode 2: Design of concrete structures, Part 1-1: General rules and rules for buildings*. CEN. 2004.
-



## 11 DCE-EN8: Design of a Rectangular CS for Shear and Axial Force

### Overview

<b>Design Code Family(s):</b>	DIN
<b>Design Code(s):</b>	DIN EN 1992-1-1
<b>Module(s):</b>	AQB
<b>Input file(s):</b>	<a href="#">rectangular_shear_axial.dat</a>

### 11.1 Problem Description

The problem consists of a rectangular section, symmetrically reinforced for bending, as shown in Fig. 11.1. The cross-section is designed for a shear force  $V_{Ed}$  and a compressive force  $N_{Ed}$  and the required reinforcement is determined.

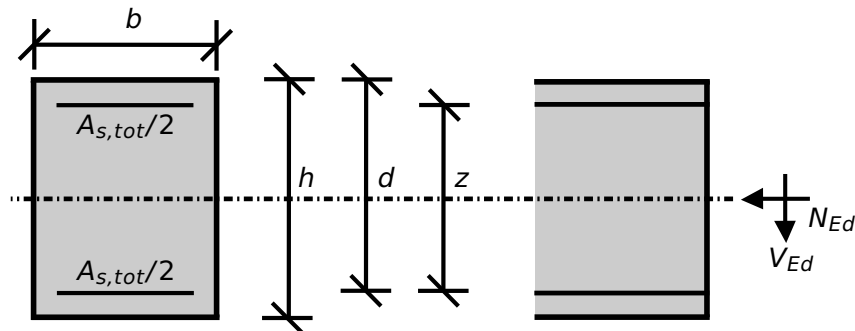

Figure 11.1: Problem Description

### 11.2 Reference Solution

This example is concerned with the design of sections for ULS, subject to shear force and axial force. The content of this problem is covered by the following parts of DIN EN 1992-1-1:2004 [1] [2]:

- Design stress-strain curves for concrete and reinforcement (Section 3.1.7, 3.2.7)
- Guidelines for shear design (Section 6.2)
- Reinforcement (Section 9.2.2)

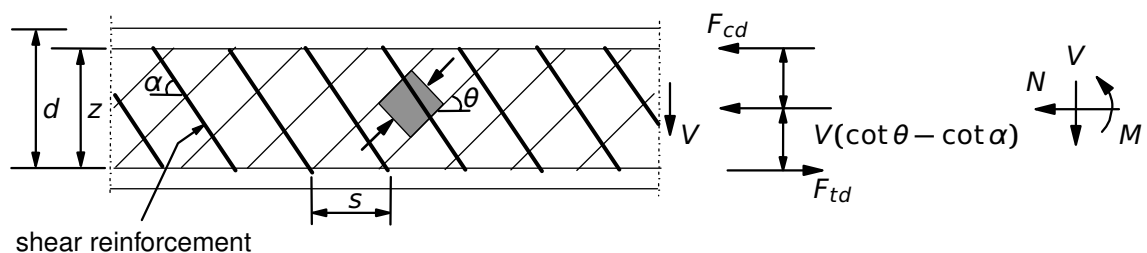

Figure 11.2: Shear Reinforced Members

The design stress-strain diagram for reinforcing steel considered in this example, consists of an inclined top branch, as presented in Fig. 11.3 and defined in DIN EN 1992-1-1:2004 [1].

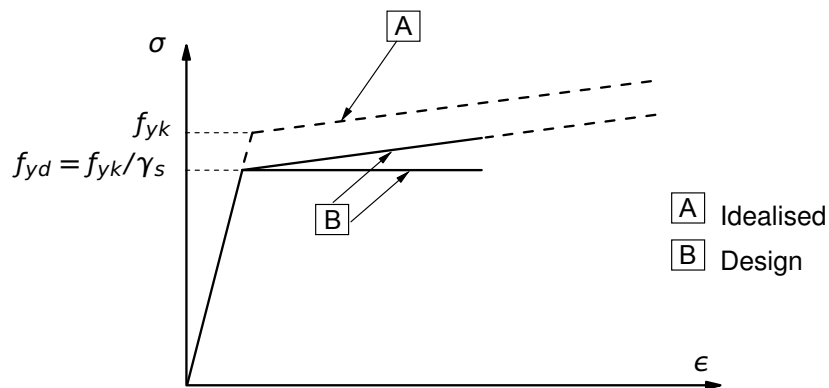

Figure 11.3: Idealised and Design Stress-Strain Diagram for Reinforcing Steel

### 11.3 Model and Results

The rectangular cross-section, with properties as defined in Table 11.1, is to be designed, with respect to DIN EN 1992-1-1:2004 (German National Annex) [1], [2], under a shear force of 343.25 kN and a compressive axial force of 500.0 kN. The reference calculation steps are presented below and the results are given in Table 11.2.

Table 11.1: Model Properties

Material Properties	Geometric Properties	Loading
C 30/37	$h = 50.0 \text{ cm}$	$V_{Ed} = 343.25 \text{ kN}$
B 500A	$b = 30 \text{ cm}$	$N_{Ed} = 500.0 \text{ kN}$
	$d = 45.0 \text{ cm}$	
	$A_{s,tot} = 38.67 \text{ cm}^2$	
	$c_{v,l} = 3.6 \text{ cm}$	

Table 11.2: Results

	SOF.	Ref.
$A_{sw} / s \text{ [cm}^2/\text{m]}$	11.27	11.27
$V_{Rd,c} \text{ [kN]}$	132.71	132.71
$\cot \theta$	1.82	1.82

## 11.4 Design Process<sup>1</sup>

### Design with respect to DIN EN 1992-1-1:2004 (NA) [1] [2]:<sup>2</sup>

Material:

Concrete:  $\gamma_c = 1.50$

Steel:  $\gamma_s = 1.15$

$f_{ck} = 30 \text{ MPa}$

$f_{cd} = a_{cc} \cdot f_{ck} / \gamma_c = 0.85 \cdot 30 / 1.5 = 17.0 \text{ MPa}$

$f_{yk} = 500 \text{ MPa}$

$f_{yd} = f_{yk} / \gamma_s = 500 / 1.15 = 434.78 \text{ MPa}$

Design Load:  $V_{Ed} = 343.25 \text{ kN}$

$N_{Ed} = -500.0 \text{ kN}$

$z = \max \{d - c_{V,l} - 30 \text{ mm}; d - 2 c_{V,l}\}$

$z = \max \{384; 378\} = 384 \text{ mm}$

$V_{Rd,c} = [C_{Rd,c} \cdot k \cdot (100 \cdot \rho_1 \cdot f_{ck})^{1/3} + 0.12 \cdot \sigma_{cp}] \cdot b_w \cdot d$

with a minimum of

$(v_{min} + 0.12 \cdot \sigma_{cp}) \cdot b_w \cdot d$

$C_{Rd,c} = 0.15 / \gamma_c = 0.1$

$k = 1 + \sqrt{\frac{200}{d}} = 1 + \sqrt{\frac{200}{450}} = 1.6667 < 2.0$

$\rho_1 = \frac{A_{s,tot}/2}{b_w d} = 0.01432 < 0.02$

$V_{Rd,c,min} = (v_{min} + 0.12 \cdot \sigma_{cp}) \cdot b_w \cdot d$

$v_{min} = (0.0525 / \gamma_c) \cdot k^{3/2} \cdot f_{ck}^{1/2} = 0.41249$

$V_{Rd,c,min} = 109.68 \text{ kN}$

$\sigma_{cp} = N_{Ed} / A_c < 0.2 \cdot f_{cd}$

$\sigma_{cp} = -500 \cdot 10^{-3} / 0.15 \cdot 10^6 = -3.3333 \text{ N/mm}^2 < 3.4$

$V_{Rd,c} = [0.1 \cdot 1.6667 \cdot (1.432 \cdot 30)^{1/3} + 0.112 \cdot 3.3333] \cdot 0.3 \cdot 0.45 = 132.71 \text{ kN}$

$V_{Ed} > V_{Rd,c} \rightarrow$  shear reinforcement is required

<sup>1</sup>The tools used in the design process are based on steel stress-strain diagrams, as defined in [1] 3.2.7:(2), Fig. 3.8, which can be seen in Fig. 11.3.

<sup>2</sup>The sections mentioned in the margins refer to DIN EN 1992-1-1:2004 (German National Annex) [1], [2], unless otherwise specified.

(NDP) 2.4.2.4: (1), Tab. 2.1DE: Partial factors for materials

Tab. 3.1: Strength for concrete

3.1.6: (1)P, Eq. (3.15):  $a_{cc} = 0.85$  considering long term effects

3.2.2: (3)P: yield strength  $f_{yk} = 500 \text{ MPa}$

3.2.7: (2), Fig. 3.8

(NDP) 6.2.3 (1): Inner lever arm  $z$

(NDP) 6.2.2 (1): Eq. 6.2a: Design value for shear resistance  $V_{Rd,c}$  for members not requiring design shear reinforcement

(NDP) 6.2.2 (1): Eq. 6.2b

(NDP) 6.2.2 (1):  $C_{Rd,c} = 0.15 / \gamma_c$

(NDP) 6.2.2 (1): Eq. 6.3aDE:  $v_{min}$  for  $d \leq 600 \text{ mm}$

(NDP) 6.2.2 (1): Eq. 6.2  $\sigma_{cp} > 0$  for compression

(NDP) 6.2.3 (2): Eq. 6.7aDE

$$1.0 \leq \cot \theta \leq \frac{1.2 + 1.4 \sigma_{cd} / f_{cd}}{1 - V_{Rd,cc} / V_{Ed}} \leq 3.0$$

(NDP) 6.2.3 (2): Eq. 6.7bDE  
 $c = 0.5$

$$V_{Rd,cc} = c \cdot 0.48 \cdot f_{ck}^{1/3} \cdot \left(1 - 1.2 \frac{\sigma_{cd}}{f_{cd}}\right) \cdot b_w \cdot z$$

(NDP) 6.2.3 (2):  $\sigma_{cd} = N_{Ed} / A_c$

$$\sigma_{cp} = N_{Ed} / A_c$$

$$\sigma_{cd} = -500 \cdot 10^{-3} / 0.15 \cdot 10^6 = -3.3333 \text{ N/mm}^2$$

6.7DE:  $\sigma_{cd} > 0$  for compression

$$V_{Rd,cc} = 0.5 \cdot 0.48 \cdot 30^{1/3} \cdot \left(1 - 1.2 \frac{3.3333}{17.0}\right) \cdot 0.3 \cdot 0.384$$

$$V_{Rd,cc} = 65.6948 \text{ kN}$$

(NDP) 6.2.3 (2): The angle  $\theta$  should be limited by Eq. 6.7DE

$$\cot \theta = \frac{1.2 + 1.4 \cdot 3.3333 / 17.0}{1 - 65.6948 / 343.25} = 1.823$$

6.2.3 (3): Eq. 6.8  
 $f_{ywd} = f_{yk} / \gamma_s = 435 \text{ MPa}$

(NDP) 6.2.3 (3): Eq. 6.9  
Maximum shear force  $V_{Rd,max}$  occurs for  $\theta = 45^\circ$ :  $\cot \theta = \tan \theta = 1$   
(NDP)  $v_1 = 0.75 \cdot v_2 = 0.75$ ,  $v_2 = 1$  for  $\leq C50/60$

$$A_{sw,requ} / s = V_{Ed} / (f_{ywd} \cdot z \cdot \cot \theta) = 11.27 \text{ cm}^2/\text{m}$$

$$V_{Rd,max} = b_w \cdot z \cdot v_1 \cdot f_{cd} / (\cot \theta + \tan \theta)$$

$$V_{Rd,max} = 0.3 \cdot 0.384 \cdot 0.75 \cdot 17 / (1 + 1) = 734.4 \text{ kN}$$



## 11.5 Conclusion

This example shows the calculation of the required reinforcement for a rectangular beam cross-section under shear with compressive axial force. It has been shown that the results are reproduced with excellent accuracy.

## 11.6 Literature

- [1] *DIN EN 1992-1-1/NA: Eurocode 2: Design of concrete structures, Part 1-1/NA: General rules and rules for buildings - German version EN 1992-1-1:2005 (D), Nationaler Anhang Deutschland - Stand Februar 2010.* CEN. 2010.
  - [2] F. Fingerloos, J. Hegger, and K. Zilch. *DIN EN 1992-1-1 Bemessung und Konstruktion von Stahlbeton- und Spannbetontragwerken - Teil 1-1: Allgemeine Bemessungsregeln und Regeln für den Hochbau.* BVPI, DBV, ISB, VBI. Ernst & Sohn, Beuth, 2012.
-



## 12 DCE-EN9: Design of a Rectangular CS for Shear and Torsion

### Overview

<b>Design Code Family(s):</b>	DIN
<b>Design Code(s):</b>	DIN EN 1992-1-1
<b>Module(s):</b>	AQB
<b>Input file(s):</b>	<a href="#">rectangular_shear_torsion.dat</a>

### 12.1 Problem Description

The problem consists of a rectangular section, symmetrically reinforced for bending, as shown in Fig. 12.1. The cross-section is designed for shear force  $V_{Ed}$  and torsion  $T_{Ed}$  and the required shear and torsion reinforcement is determined.

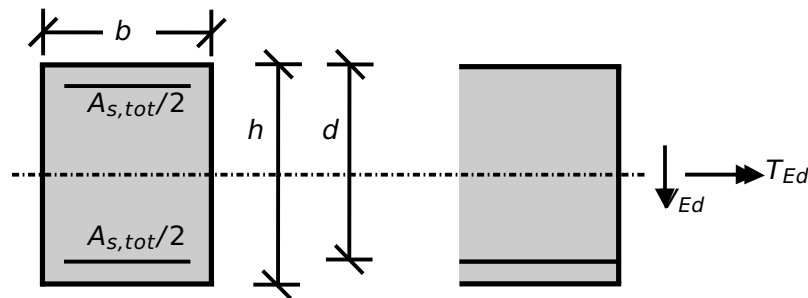

Figure 12.1: Problem Description

### 12.2 Reference Solution

This example is concerned with the design of sections for ULS, subject to shear force and torsion. The content of this problem is covered by the following parts of DIN EN 1992-1-1:2004 [1] [2]:

- Design stress-strain curves for concrete and reinforcement (Section 3.1.7, 3.2.7)
- Guidelines for shear (Section 6.2) and torsion design (Section 6.3)
- Reinforcement (Section 9.2.2, 9.2.3)

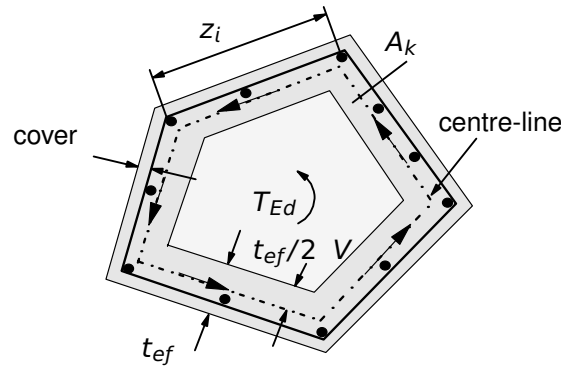

Figure 12.2: Torsion Reinforced Members

The design stress-strain diagram for reinforcing steel considered in this example, consists of an inclined top branch, as presented in Fig. 12.3 and as defined in DIN EN 1992-1-1:2004 [1] (Section 3.2.7).

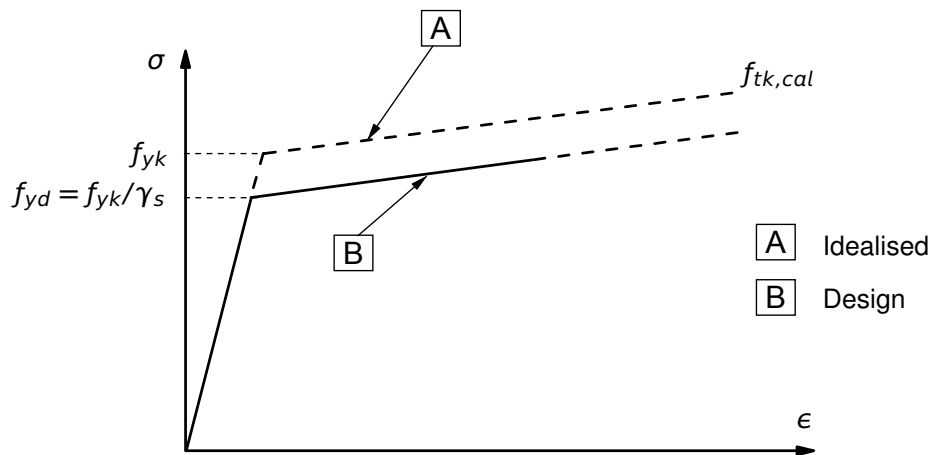

Figure 12.3: Idealised and Design Stress-Strain Diagram for Reinforcing Steel

## 12.3 Model and Results

The rectangular cross-section, with properties as defined in Table 12.1, is to be designed, with respect to DIN EN 1992-1-1:2004 (German National Annex) [1], [2], under shear force of 175.0 kN and torsional moment 35 kNm. The reference calculation steps [4] are presented below and the results are given in Table 12.2.

Table 12.1: Model Properties

Material Properties	Geometric Properties	Loading
C 35/45	$h = 70.0 \text{ cm}$	$V_{Ed} = 175.0 \text{ kN}$
B 500A	$b = 30 \text{ cm}$	$T_{Ed} = 35.0 \text{ kNm}$
	$d = 65.0 \text{ cm}$	
	$A_{s,tot} = 26.8 \text{ cm}^2$	

Table 12.2: Results

	SOF	Ref.
$A_{sw} / s_w (T) [cm^2/m]$	3.35	3.35
$A_{sl} (T) [cm^2]$	5.37	5.37
$A_{sw,total} / s [cm^2/m]$	13.60	13.59
$V_{Rd,c} [kN]$	110.13	113.12
$V_{Rd,max} [kN]$	1303.05	1303.03
$T_{Rd,max} [kNm]$	124.95	124.95

## 12.4 Design Process <sup>1</sup>

### Design with respect to DIN EN 1992-1-1:2004 (NA) [1] [2]:<sup>2</sup>

Material:

(NA) 2.4.2.4: (1), Tab. 2.1DE: Partial factors for materials

Concrete:  $\gamma_c = 1.50$

Steel:  $\gamma_s = 1.15$

Tab. 3.1: Strength for concrete

$f_{ck} = 30 \text{ MPa}$

(NDP) 3.1.6: (1)P, Eq. (3.15):  $\alpha_{cc} = 0.85$  considering long term effects

$f_{cd} = \alpha_{cc} \cdot f_{ck} / \gamma_c = 0.85 \cdot 35 / 1.5 = 19.833 \text{ MPa}$

(NDP) 3.2.2: (3)P: yield strength  $f_{yk} = 500 \text{ MPa}$

$f_{yk} = 500 \text{ MPa}$

3.2.7: (2), Fig. 3.8

$f_{yd} = f_{yk} / \gamma_s = 500 / 1.15 = 434.78 \text{ MPa}$

Design Load:

$V_{Ed} = 175.0 \text{ kN}, T_{Ed} = 35.0 \text{ kN}$

(NDP) 6.3.2 (5): Eq. (NA.6.31.1): For approximately rectangular solid sections no shear and torsion reinforcement is required except from the minimum reinforcement, provided that the condition is satisfied

$$T_{Ed} \leq \frac{V_{Ed} \cdot b_w}{4.5}$$

$$35 > \frac{175 \cdot 0.3}{4.5} = 11.66$$

→ Eq. NA.6.31.1 is not fulfilled

and (NDP) 6.3.2 (5): Eq. (NA.6.31.2): When the condition equation is not fulfilled then shear and torsion design has to be reverified

$$V_{Ed} \cdot \left[ 1 + \frac{4.5 \cdot T_{Ed}}{V_{Ed} \cdot b_w} \right] \leq V_{Rd,c}$$

(NDP) 6.2.2 (1): Eq. 6.2a: Design value for shear resistance  $V_{Rd,c}$  for members not requiring design shear reinforcement

$$V_{Rd,c} = \left[ C_{Rd,c} \cdot k \cdot (100 \cdot \rho_1 \cdot f_{ck})^{1/3} + 0.12 \cdot \sigma_{cp} \right] \cdot b_w \cdot d$$

(NDP) 6.2.2 (1):  $C_{Rd,c} = 0.15 / \gamma_c$

$$C_{Rd,c} = 0.15 / \gamma_c = 0.1$$

$$k = 1 + \sqrt{\frac{200}{d}} < 2.0$$

$$k = 1 + \sqrt{\frac{200}{650}} = 1.5547 < 2.0$$

$$\rho_1 = \frac{A_{sl}}{b_w \cdot d}$$

$$\rho_1 = \frac{26.8 \cdot 100^{-2}}{0.3 \cdot 0.65} = 0.0137 < 0.02$$

$$V_{Rd,c} = \left[ 0.1 \cdot 1.5547 \cdot (100 \cdot 0.0137 \cdot 35)^{1/3} + 0 \right] \cdot 0.3 \cdot 0.65$$

$$V_{Rd,c} = 0.11013 \text{ MN} = 110.13 \text{ kN}$$

$$175 \cdot \left[ 1 + \frac{4.5 \cdot 35}{175 \cdot 0.3} \right] = 700 > 111.74$$

<sup>1</sup>The tools used in the design process are based on steel stress-strain diagrams, as defined in [1] 3.2.7:(2), Fig. 3.8, which can be seen in Fig. 12.3.

<sup>2</sup>The sections mentioned in the margins refer to DIN EN 1992-1-1:2004 (German National Annex) [1], [2], unless otherwise specified.

→ requirement of Eq. NA.6.31.2 is not met

### Torsional reinforcement

$$t_{eff,1} = t_{eff,2} = 2 \cdot 50 = 100 \text{ mm} \quad (s_o = s_u = s_s = 50 \text{ mm})$$

$$A_k = (h - s_u - s_o) \cdot (b_w - t_{eff,1}) = 100 \text{ mm}$$

$$A_k = (700 - 50 - 50) \cdot (300 - 100) = 120000 \text{ mm}^2 = 0.12 \text{ m}^2$$

$$u_k = 2 \cdot [(700 - 50 - 50) + (300 - 100)] = 1600 \text{ mm} = 1.6 \text{ m}$$

Simplifying, the reinforcement for torsion may be determined alone under the assumption of  $\cot \theta = 1.0$ ,  $\theta = 45^\circ$  and be added to the independently calculated shear force reinforcement.

$$A_{sw,requ} / s_w = T_{Ed} \cdot \tan \theta / (f_{yd} \cdot 2A_k)$$

$$A_{sw,requ} / s_w = 350 \cdot 1.0 / (435 \cdot 2 \cdot 0.12) = 3.35 \text{ cm}^2/\text{m} \quad (T)$$

$$A_{sl,requ} = T_{Ed} \cdot u_k \cdot \cot \theta / (f_{yd} \cdot 2A_k) = 5.37 \text{ cm}^2 \quad (T)$$

### Torsional resistance moment

$$T_{Rd,max} = 2 \cdot \nu \cdot f_{cd} \cdot A_k \cdot t_{eff,i} \cdot \sin \theta \cdot \cos \theta$$

$$\sin \theta \cdot \cos \theta = 0.5 \text{ since } \theta = 45^\circ$$

$$T_{Rd,max} = 124.95 \text{ kNm}$$

### Check of the concrete compressive strut bearing capacity for the load combination of shear force and torsion

The maximum resistance of a member subjected to torsion and shear is limited by the capacity of the concrete struts. The following condition should be satisfied:

$$\left[ \frac{T_{Ed}}{T_{Rd,max}} \right]^2 + \left[ \frac{V_{Ed}}{V_{Rd,max}} \right]^2 \leq 1.0$$

For the T+V utilization, SOFiSTiK uses:

$$\sqrt{\left[ \frac{T_{Ed}}{T_{Rd,max}} \right]^2 + \left[ \frac{V_{Ed}}{V_{Rd,max}} \right]^2} \leq 1.0$$

$$z = \max \{ d - c_{v,l} - 30 \text{ mm}; d - 2 c_{v,l} \}$$

$$c_{v,l} = s_o - D_o/2 = 50 - 28/2 = 36 \text{ mm}$$

$$z = \max \{ 584; 578 \} = 584 \text{ mm}$$

$$V_{Rd,max} = b_w \cdot z \cdot \nu_1 \cdot f_{cd} / (\cot \theta + \tan \theta)$$

$$V_{Rd,max} = 0.3 \cdot 0.584 \cdot 0.75 \cdot 19.833 / (1 + 1) = 1303.03 \text{ kN}$$

$$\left[ \frac{35}{124.95} \right]^2 + \left[ \frac{175}{1303.04} \right]^2 = 0.0965 < 1$$

### Shear reinforcement

6.3.1 (3): Solid sections may be modelled by equivalent thin-walled sections (Fig. 12.2)

$A_k$ : area enclosed by the centre-line

$u_k$ : circumference of area  $A_k$

6.3.2 (2): The effects of torsion and shear may be superimposed, assuming the same value for  $\theta$

(NDP) 6.3.2 (3): Eq. (NA.6.28.1)

6.3.2 (3): Eq. 6.28

6.3.2 (4): Eq. 6.30

(NDP):  $\nu = 0.525$

(NDP) 6.3.2 (4): Eq. (NA.6.29.1) for solid cross-sections

(NDP) 6.2.3 (1): Inner lever arm  $z$

$s_o$ : offset of reinforcement  
 $D_o$ : bar diameter

(NDP) 6.2.3 (3): Eq. 6.9

Maximum shear force  $V_{Rd,max}$  occurs for  $\theta = 45^\circ$ :  $\cot \theta = \tan \theta = 1$

(NDP) 6.2.3 (3):  $\nu_1 = 0.75 \cdot \nu_2 = 0.75$ ,  $\nu_2 = 1$  for  $\leq C50/60$

6.2.3 (3): Eq. 6.8  
 $f_{ywd} = f_{yk} / \gamma_s = 435 \text{ MPa}$

$$A_{sw,requ} / s = V_{Ed} / (f_{ywd} \cdot z \cdot \cot \theta) = 6.89 \text{ cm}^2/\text{m}$$

### Total required reinforcement

Required torsional reinforcement:

$$2 \cdot A_{sw}/s_w = 2 \cdot 3.35 = 6.7 \text{ cm}^2/\text{m} \text{ (double-shear connection)}$$

$$\text{Total reinforcement: } A_{sw,total}/s = 6.7 + 6.89 = 13.59 \text{ cm}^2/\text{m}$$

### Check the maximum allowable compressive stress

$$\begin{aligned} v_{cv} &= 0.750 \cdot \eta_1 \cdot \min(1.0, 1.1 - \frac{f_{ck}}{500}) \\ &= 0.750 \cdot 1.00 \cdot \min(1.0, 1.1 - \frac{35}{500}) \\ &= 0.750 \end{aligned}$$

$$\begin{aligned} v_{cv} &= 0.525 \cdot \eta_1 \cdot \min(1.0, 1.1 - \frac{f_{ck}}{500}) \\ &= 0.525 \cdot 1.00 \cdot \min(1.0, 1.1 - \frac{35}{500}) \\ &= 0.525 \end{aligned}$$

$$\begin{aligned} \sigma_{cv} &= v_{cv} \cdot f_{cd} \\ &= 0.75 \cdot 19.83 \\ &= 14.88 \end{aligned}$$

$$\begin{aligned} \sigma_{ct} &= v_{ct} \cdot f_{cd} \\ &= 0.525 \cdot 19.83 \\ &= 10.41 \end{aligned}$$

$$\sigma_{II} < \sigma_{c,v+t}$$

$$-4.91 \text{ MPa} < -14.88 \text{ MPa} \rightarrow \text{OK}$$



## 12.5 Conclusion

This example shows the calculation of the required reinforcement for a rectangular beam cross-section under shear and torsion. It has been shown that the results are reproduced with excellent accuracy.

## 12.6 Literature

- [1] *DIN EN 1992-1-1/NA: Eurocode 2: Design of concrete structures, Part 1-1/NA: General rules and rules for buildings - German version EN 1992-1-1:2005 (D), Nationaler Anhang Deutschland - Stand Februar 2010.* CEN. 2010.
  - [2] F. Fingerloos, J. Hegger, and K. Zilch. *DIN EN 1992-1-1 Bemessung und Konstruktion von Stahlbeton- und Spannbetontragwerken - Teil 1-1: Allgemeine Bemessungsregeln und Regeln für den Hochbau.* BVPI, DBV, ISB, VBI. Ernst & Sohn, Beuth, 2012.
  - [4] *Beispiele zur Bemessung nach Eurocode 2 - Band 1: Hochbau.* Ernst & Sohn. Deutschen Beton- und Bautechnik-Verein E.V. 2011.
-



## 13 DCE-EN10: Shear between web and flanges of T-sections

### Overview

<b>Design Code Family(s):</b>	DIN
<b>Design Code(s):</b>	DIN EN 1992-1-1
<b>Module(s):</b>	AQB
<b>Input file(s):</b>	<a href="#">t-beam_shear_web_flange.dat</a>

### 13.1 Problem Description

The problem consists of a T-beam section, as shown in Fig. 13.1. The cs is designed for shear, the shear between web and flanges of T-sections is considered and the required reinforcement is determined.

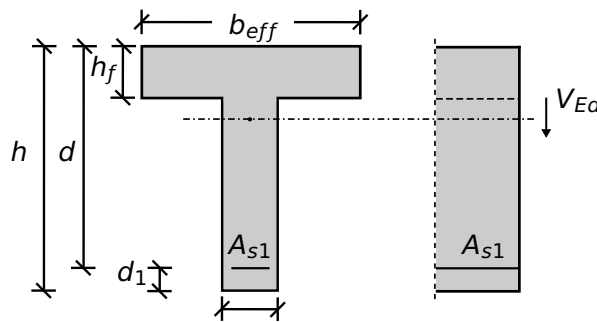

Figure 13.1: Problem Description

### 13.2 Reference Solution

This example is concerned with the shear design of T-sections, for the ultimate limit state. The content of this problem is covered by the following parts of DIN EN 1992-1-1:2004 [1]:

- Design stress-strain curves for concrete and reinforcement (Section 3.1.7, 3.2.7)
- Guidelines for shear design (Section 6.2)

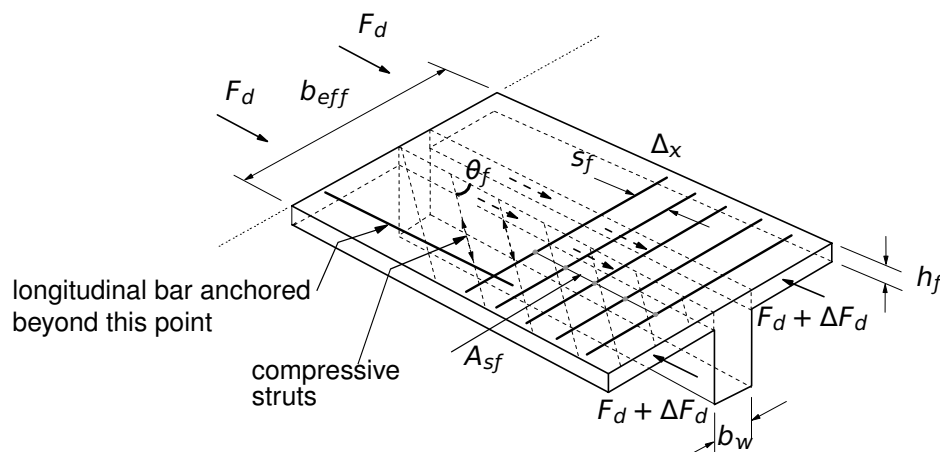

Figure 13.2: Connection between flange and web in T-sections

The design stress-strain diagram for reinforcing steel considered in this example, consists of an inclined top branch, as presented in Fig. 13.3 and as defined in DIN EN 1992-1-1:2004 [1] (Section 3.2.7).

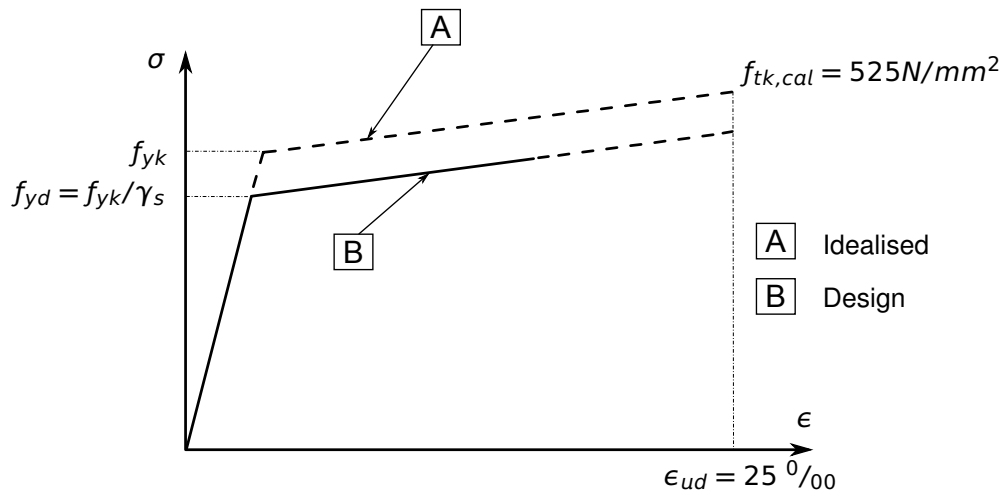

Figure 13.3: Idealised and Design Stress-Strain Diagram for Reinforcing Steel

### 13.3 Model and Results

The T-section, with properties as defined in Table 13.1, is to be designed for shear, with respect to DIN EN 1992-1-1:2004 (German National Annex) [1], [2]. The structure analysed, consists of a single span beam with a distributed load in gravity direction. The cross-section geometry, as well as the shear cut under consideration can be seen in Fig. 13.4.

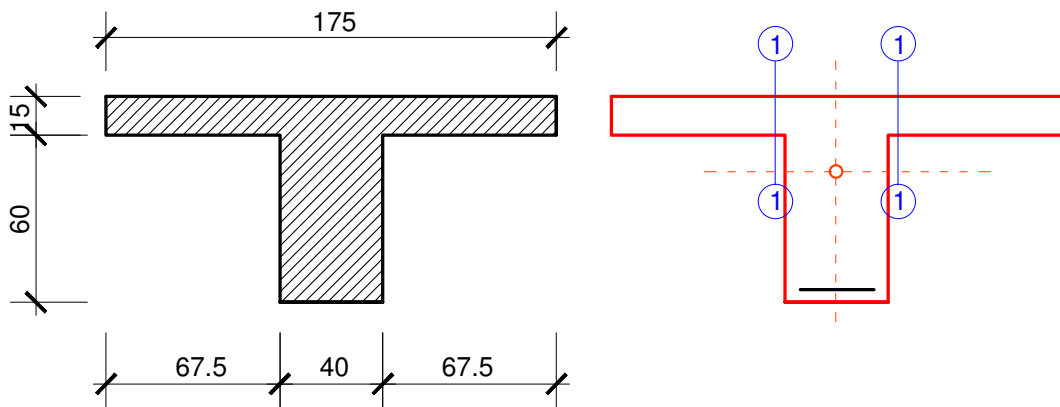

Figure 13.4: Cross-section Geometry, Properties and Shear Cuts

Table 13.1: Model Properties

Material Properties	Geometric Properties	Loading
C 20/25	$h = 75.0 \text{ cm}$	$P_g = 155 \text{ kN/m}$
B 500A	$h_f = 15 \text{ cm}, h_w = 60.0 \text{ cm}$ $d_1 = 7.0 \text{ cm}$	

Table 13.1: (continued)

Material Properties	Geometric Properties	Loading
	$b_w = 40 \text{ cm}$	
	$b_{eff,i} = 67.5 \text{ cm}, b_{eff} = 175 \text{ cm}$	

The system with its loading as well as the moment and shear force are shown in Fig. 13.5. The reference calculation steps [4] are presented in the next section and the results are given in Table 13.2.

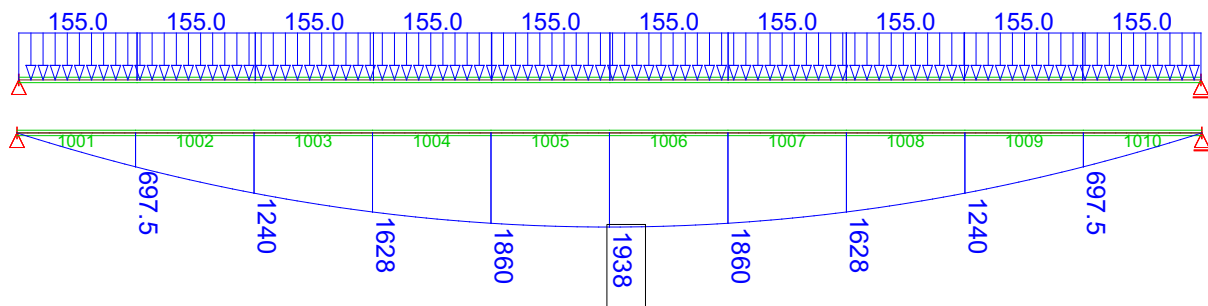

Figure 13.5: Loaded Structure, Resulting Moment and Shear Force

Table 13.2: Results

At beam 1001	SOF.	Ref.
$A_{s1} \text{ [cm}^2\text{] at } x = 1.0 \text{ m}$	23.26	23.27
$A_{sf} / s_f \text{ [cm}^2\text{/m]}$	5.71	5.79
$V_{Rd,c} \text{ [kN]}$	61.05	61.2
$V_{Rd,max} \text{ [kN]}$	711.61	712.53
$\cot \theta$	1.62	1.619
$z \text{ [cm] at } x = 1.0 \text{ m}$	65.72	65.7
$V_{Ed} = \Delta F_d \text{ [kN]}$	403.65	409.36

## 13.4 Design Process<sup>1</sup>

### Design with respect to DIN EN 1992-1-1:2004 (NA) [1] [2]:<sup>2</sup>

Material:

(NDP) 2.4.2.4: (1), Tab. 2.1DE: Partial factors for materials

Concrete:  $\gamma_c = 1.50$

Steel:  $\gamma_s = 1.15$

Tab. 3.1: Strength for concrete

3.1.6: (1)P, Eq. (3.15):  $\alpha_{cc} = 0.85$  considering long term effects

3.2.2: (3)P: yield strength  $f_{yk} = 500$  MPa

3.2.7: (2), Fig. 3.8

$$f_{ck} = 25 \text{ MPa}$$

$$f_{cd} = \alpha_{cc} \cdot f_{ck} / \gamma_c = 0.85 \cdot 25 / 1.5 = 14.17 \text{ MPa}$$

$$f_{yk} = 500 \text{ MPa}$$

$$f_{yd} = f_{yk} / \gamma_s = 500 / 1.15 = 434.78 \text{ MPa}$$

$$\sigma_{sd} = 456.52 \text{ MPa}$$

#### Design loads

- Design Load for beam 1001,  $x=0.0$  m:

$$M_{Ed, x=0.0 \text{ m}} = 0.0 \text{ kNm}$$

- Design Load for beam 1001,  $x=1.0$  m:

$$M_{Ed, x=1.0 \text{ m}} = 697.5 \text{ kNm}$$

#### Calculating the longitudinal reinforcement:

- For beam 1001,  $x=0.0$  m

$$\mu = 0 \rightarrow A_{s1} = 0$$

$$\mu_{Eds} = \frac{M_{Eds}}{b_{eff} \cdot d^2 \cdot f_{cd}} = \frac{0.0 \cdot 10^{-3}}{1.75 \cdot 0.68^2 \cdot 14.17} = 0.00$$

- For beam 1001,  $x=1.0$  m

$$\mu_{Eds} = \frac{M_{Eds}}{b_{eff} \cdot d^2 \cdot f_{cd}} = \frac{697.5 \cdot 10^{-3}}{1.75 \cdot 0.68^2 \cdot 14.17} = 0.0608$$

Tab. 9.2 [3]:  $\omega$ —Table for up to C50/60 without compression reinforcement

$$N_{Ed} = 0$$

$\omega \approx 0.063$ ,  $\zeta \approx 0.967$  and  $\xi \approx 0.086$  (interpolated)

$$A_{s1} = \frac{1}{\sigma_{sd}} \cdot (\omega \cdot b \cdot d \cdot f_{cd} + N_{Ed})$$

$$A_{s1} = \frac{1}{456.52} \cdot (0.063 \cdot 1.75 \cdot 0.68 \cdot 14.17) \cdot 100^2 = 23.27 \text{ cm}^2$$

$$z = \zeta \cdot d = 0.967 \cdot 0.68 \text{ m} \approx 65.7 \text{ cm}$$

#### Calculating the shear between flange and web

The shear force, is determined by the change of the longitudinal force, at the junction between one side of a flange and the web, in the separated flange:

6.2.4 (3): Eq. 6.20

<sup>1</sup>The tools used in the design process are based on steel stress-strain diagrams, as defined in [1] 3.2.7:(2), Fig. 3.8, which can be seen in Fig. 13.3.

<sup>2</sup>The sections mentioned in the margins refer to DIN EN 1992-1-1:2004 (German National Annex) [1], [2], unless otherwise specified.

$$\Delta F_d = \left( \frac{M_{Ed,x=1.0}}{z} - \frac{M_{Ed,x=0.0}}{z} \right) \cdot \frac{h_f \cdot b_{eff,i}}{h_f \cdot b_{eff}}$$

For beam 1001 ( $x=0.00$  m)  $\rightarrow M_{Ed} = 0.00$  therefore:

$$\Delta F_d = \left( \frac{697.5}{0.657} - 0 \right) \cdot \frac{0.675}{1.75} = 409.36 \text{ kN}$$

In AQB output  $\Delta F_d = T$  [kN/m]

The longitudinal shear stress  $v_{Ed}$  at the junction between one side of a flange and the web is determined by the change of the normal (longitudinal) force in the part of the flange considered, according to:

$$v_{Ed} = \frac{\Delta F_d}{h_f \cdot \Delta x}$$

DIN EN 1992, 6.2.4 (3), Eq. 6.20:  $h_f$  is the thickness of flange at the junctions,  $\Delta x$  is the length under consideration,  $\Delta F_d$  is the change of the normal force in the flange over the length  $\Delta x$

In our case  $\Delta x = 1.0$  because the beam length is = 1.00 m.

Please note that AQB is outputting the results per length.

$$v_{Ed} = \frac{409.36}{15 \cdot 100} = 0.272 \text{ kN/m}^2 = 2.72 \text{ MPa}$$

In AQB output  $v_{Ed} = \tau - V$

### Checking the maximum $v_{Rd,max}$ value to prevent crushing of the struts in the flange

To prevent crushing of the compression struts in the flange, the following condition should be satisfied:

$$v_{Ed} \leq v_{Rd,max} = v \cdot f_{cd} \cdot \sin\theta_f \cdot \cos\theta_f$$

DIN EN 1992, 6.2.4 (4), Eq. 6.22

$$v_{Rd,max} = v \cdot f_{cd} \cdot \sin\theta_f \cdot \cos\theta_f$$

According to DIN EN 1992-1-1, NDP 6.2.4(4):

$$v = v_1$$

$$v_1 = 0.75 \cdot v_2$$

DIN EN 1992, NDP 6.2.3 (3), Eq. 6.22

$$v_2 = 1.1 - \frac{f_{ck}}{500} \leq 1.0$$

$$v_2 = 1.1 - \frac{20}{500} = 1.1 - 0.04 = 1.06 \geq 1.0 \rightarrow v_2 = 1.0$$

$$v_1 = 0.75 \cdot 1.0 = 0.75 \rightarrow v = 0.75$$

The  $\theta$  value is calculated:

$$v_{Rd,cc} = c \cdot 0.48 \cdot f_{ck}^{1/3} \cdot \left( 1 - 1.2 \cdot \frac{\sigma_{cd}}{f_{cd}} \right) \cdot b_w \cdot z$$

DIN EN 1992, NDP 6.2.3 (2), Eq. NA.6.7b:  $\sigma_{cd} = N_{Ed}/A_c$ ,  $c=0.5$

$$b_w \rightarrow h_f, \quad z \rightarrow \Delta x, \quad c = 0.5$$

$$v_{Rd,cc} = c \cdot 0.48 \cdot f_{ck}^{1/3} \cdot \left( 1 - 1.2 \cdot \frac{\sigma_{cd}}{f_{cd}} \right) \cdot h_f \cdot \Delta x$$

$$v_{Rd,cc} = 0.5 \cdot 0.48 \cdot 25^{1/3} \cdot \left( 1 - 1.2 \cdot \frac{0}{14.17} \right) \cdot 0.15 \cdot 1.0$$

$$v_{Rd,cc} = 0.1052 \text{ MN} = 105.26 \text{ kN}$$

DIN EN 1992, NDP 6.2.3 (2), Eq. NA.6.7a

$$1.0 \leq \cot\theta \leq \frac{1.2 + 1.4 \cdot \Delta\sigma_{cd}/f_{cd}}{1 - V_{Rd,cc}/V_{Ed}} \leq 3.0$$

$$\cot\theta = \frac{1.2}{1 - 105.26/409.36} = 1.619$$

$$\tan\theta = \frac{1}{\cot\theta} = \frac{1}{1.619} = 0.619 \rightarrow \theta = 31.75^\circ$$

$$v_{Rd,max} = 0.75 \cdot 14.17 \cdot \sin 31.75 \cdot \cos 31.75 = 4.7502 \text{ MPa}$$

$$V_{Rd,max} = v_{Rd,max} \cdot h_f \cdot \Delta x = 4.7502 \cdot 0.15 \cdot 1.0 = 0.71253 \text{ MN}$$

$$V_{Rd,max} = 712.53 \text{ kN}$$

#### Checking the value $v_{Rd,c}$

If  $v_{Ed}$  is less than or equal to  $v_{Rd,c} = k \cdot f_{ctd}$  no extra reinforcement above that for flexure is required.

$$v_{Rd,c} = k \cdot f_{ctd}$$

For concrete C 25/30  $\rightarrow f_{ctd} = 1.02 \text{ MPa}$

$$v_{Rd,c} = 0.4 \cdot 1.02 = 0.408 \text{ MPa}$$

$$V_{Rd,c} = v_{Rd,c} \cdot h_f \cdot \Delta x = 0.408 \cdot 15 \cdot 100 = 61.2 \text{ kN}$$

- Calculating the necessary transverse reinforcement:

DIN EN 1992, 6.2.4 (4), Eq. 6.21

$$a_{sf} = \frac{v_{Ed} \cdot h_f}{\cot\theta_f \cdot f_{yd}}$$

$$a_{sf} = \frac{2.72 \cdot 0.15}{1.619 \cdot 434.78} \cdot 100^2 = 5.79 \text{ cm}^2$$



## 13.5 Conclusion

This example is concerned with the calculation of the shear between web and flanges of T-sections. It has been shown that the results are reproduced with good accuracy.

## 13.6 Literature

- [1] *DIN EN 1992-1-1/NA: Eurocode 2: Design of concrete structures, Part 1-1/NA: General rules and rules for buildings - German version EN 1992-1-1:2005 (D), Nationaler Anhang Deutschland - Stand Februar 2010.* CEN. 2010.
  - [2] F. Fingerloos, J. Hegger, and K. Zilch. *DIN EN 1992-1-1 Bemessung und Konstruktion von Stahlbeton- und Spannbetontragwerken - Teil 1-1: Allgemeine Bemessungsregeln und Regeln für den Hochbau.* BVPI, DBV, ISB, VBI. Ernst & Sohn, Beuth, 2012.
  - [3] K. Holschemacher, T. Müller, and F. Lobisch. *Bemessungshilfsmittel für Betonbauteile nach Eurocode 2 Bauingenieure.* 3rd. Ernst & Sohn, 2012.
  - [4] *Beispiele zur Bemessung nach Eurocode 2 - Band 1: Hochbau.* Ernst & Sohn. Deutschen Beton- und Bautechnik-Verein E.V. 2011.
-



## 14 DCE-EN11: Shear at the interface between concrete cast

### Overview

<b>Design Code Family(s):</b>	DIN
<b>Design Code(s):</b>	DIN EN 1992-1-1
<b>Module(s):</b>	AQB
<b>Input file(s):</b>	<a href="#">shear_interface.dat</a>

### 14.1 Problem Description

The problem consists of a T-beam section, as shown in Fig. 14.1. The cs is designed for shear, the shear at the interface between concrete cast at different times is considered and the required reinforcement is determined.

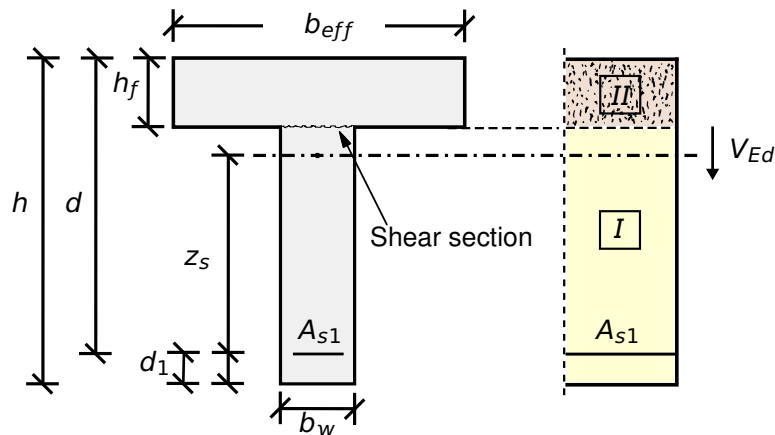

Figure 14.1: Problem Description

### 14.2 Reference Solution

This example is concerned with the shear design of T-sections, for the ultimate limit state. The content of this problem is covered by the following parts of DIN EN 1992-1-1:2004 [1]:

- Design stress-strain curves for concrete and reinforcement (Section 3.1.7, 3.2.3)
- Guidelines for shear design (Section 6.2)

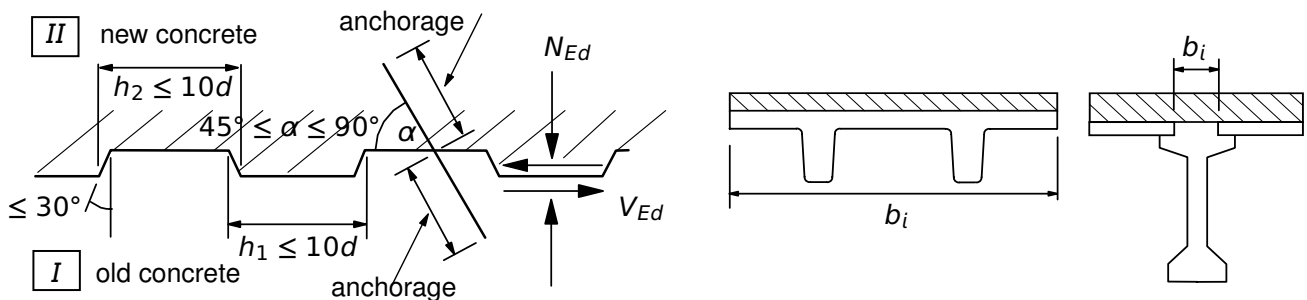

Figure 14.2: Indented Construction Joint - Examples of Interfaces

The design stress-strain diagram for reinforcing steel considered in this example, consists of an inclined top branch, as presented in Fig. 14.3 and as defined in DIN EN 1992-1-1:2004 [1] (Section 3.2.7).

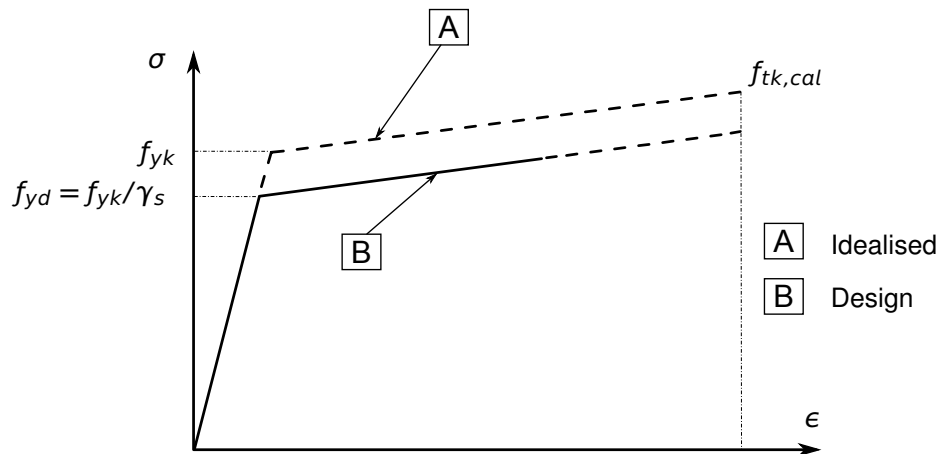

Figure 14.3: Idealised and Design Stress-Strain Diagram for Reinforcing Steel

### 14.3 Model and Results

The T-section, with properties as defined in Table 14.1, is to be designed for shear, with respect to DIN EN 1992-1-1:2004 (German National Annex) [1], [2]. The reference calculation steps [4] are presented in the next section and the results are given in Table 14.2.

Table 14.1: Model Properties

Material Properties	Geometric Properties	Loading
C 20/25	$h = 135.0 \text{ cm}$	$V_z = 800 \text{ kN}$
B 500A	$h_f = 29 \text{ cm}$	$M_y = 2250 \text{ kNm}$
	$d_1 = 7.0 \text{ cm}$	
	$b_w = 40 \text{ cm}, b_{eff} = 250 \text{ cm}$	
	$A_{s1} = 1.0 \text{ cm}^2$	
	$z_s = 95.56 \text{ cm}$	

Table 14.2: Results

$a_s \text{ [cm}^2\text{/m]}$	SOF.	Ref.
state I	7.00	7.07
state II only V	4.86	4.90
state II V + M	4.99	4.99

## 14.4 Design Process <sup>1</sup>

### Design with respect to DIN EN 1992-1-1:2004 (NA) [1] [2]:<sup>2</sup>

Material:

Concrete:  $\gamma_c = 1.50$

Steel:  $\gamma_s = 1.15$

$f_{ck} = 25 \text{ MPa}$

$f_{cd} = \alpha_{cc} \cdot f_{ck} / \gamma_c = 0.85 \cdot 25 / 1.5 = 14.17 \text{ MPa}$

$f_{yk} = 500 \text{ MPa}$

$f_{yd} = f_{yk} / \gamma_s = 500 / 1.15 = 434.78 \text{ MPa}$

$\sigma_{sd} = 456.52 \text{ MPa}$

$$\tau = \frac{T_v}{b_w} = \frac{V \cdot S}{I_y \cdot b_w}$$

where  $S$  is the static moment of the separated area

$S = h_w \cdot b_w \cdot (z_s - h_w/2) = 0.18058 \text{ m}^3$

$$\tau = \frac{0.8 \cdot 0.18058}{0.16667 \cdot 0.4} = 2.1669 \text{ MPa}$$

$$T_v = \frac{0.8 \cdot 0.18058}{0.16667} = 0.86676 \text{ MN/m} = 866.76 \text{ kN/m}$$

$$T_v = 866.76 / 2 = 433.38 \text{ kN/m}$$

**State I:**

Design Load:

$$V_{Edi} = T_v = 433.38 \text{ kN/m}$$

$$v_{Edi} = \tau = 2.1669 \text{ MPa}$$

$$V_{Rd,c} = \left[ C_{Rd,c} \cdot k \cdot (100 \cdot \rho_1 \cdot f_{ck})^{1/3} + 0.12 \cdot \sigma_{cp} \right] \cdot b_w \cdot d$$

$$v_{Rd,c} = C_{Rd,c} \cdot k \cdot (100 \cdot \rho_1 \cdot f_{ck})^{1/3} + 0.12 \cdot \sigma_{cp}$$

$$\rho_1 = \frac{A_{st}}{b_w d} = 0.0 \rightarrow v_{Rd,c} = 0.0$$

with a minimum of

$$V_{Rd,c,min} = (v_{min} + 0.12 \cdot \sigma_{cp}) \cdot b_w \cdot d$$

$$v_{Rd,c,min} = v_{min} + 0.12 \cdot \sigma_{cp}$$

$$v_{min} = (0.0375 / \gamma_c) \cdot k^{3/2} \cdot f_{ck}^{1/2} = 0.20833 \text{ MPa}$$

<sup>1</sup>The tools used in the design process are based on steel stress-strain diagrams, as defined in [1] 3.2.7:(2), Fig. 3.8, which can be seen in Fig. 14.3.

<sup>2</sup>The sections mentioned in the margins refer to DIN EN 1992-1-1:2004 (German National Annex) [1], [2], unless otherwise specified.

(NDP) 2.4.2.4: (1), Tab. 2.1DE: Partial factors for materials

Tab. 3.1: Strength for concrete

3.1.6: (1)P, Eq. (3.15):  $\alpha_{cc} = 0.85$  considering long term effects

3.2.2: (3)P: yield strength  $f_{yk} = 500 \text{ MPa}$

3.2.7: (2), Fig. 3.8

The shear section with a length of 0.4 m is split into two equal parts with  $b_i = 0.2 \text{ m}$

The associated design shear flow  $V_{Edi}$  is:

(NDP) 6.2.2 (1): Eq. 6.2a: Design value for shear resistance  $V_{Rd,c}$  for members not requiring design shear reinforcement

(NDP) 6.2.2 (1): Eq. 6.2b

(NDP) 6.2.2 (1): Eq. 6.3bDE

$$V_{Rd,c,min} = 0.20833 \rightarrow v_{Rd,c} = 0.20833 \text{ MPa}$$

$V_{Edi} > v_{Rd,c} \rightarrow$  shear reinforcement is required

6.2.5 (1): Eq. 6.23: The design shear stress at the interface should satisfy this (NDP) 6.2.5 (1): Eq. 6.25

$$V_{Edi} \leq V_{Rdi}$$

$$V_{Rdi} = c \cdot f_{ctd} + \mu \cdot \sigma_n + \rho \cdot f_{yd} \cdot (1.2 \cdot \mu \cdot \sin \alpha + \cos \alpha)$$

Maximum shear stress  $v_{Rdi,max}$   
(NDP) 6.2.5 (1):  $v = 0.70$  for indented surface

$$\text{and } v_{Rdi} \leq 0.5 \cdot v \cdot f_{cd}$$

$$v_{Rdi,max} = 0.5 \cdot v \cdot f_{cd} = 4.9585 \text{ MPa}$$

6.2.5 (2):  $c, \mu$ : factors depending on the roughness of the interface

$c = 0.50$  and  $\mu = 0.9$  for indented surface

(NDP) 3.1.6 (2)P: Eq. 3.16

$$f_{ctd} = \alpha_{ct} \cdot f_{ctk;0.05} / \gamma_c$$

$\alpha_{ct} = 0.85$

3.1.2 (3): Tab. 3.1 - Strength for concrete:  $f_{ctk;0.05} = 1.8 \text{ MPa}$ :

$$f_{ctd} = 0.85 \cdot 1.80 / 1.5 = 1.02$$

$\rho = \frac{a_s}{b_i \cdot l_i}$ : area of reinforcement crossing interface / area of joint

$$V_{Rdi} = 0.5 \cdot 1.02 + 0 + \frac{a_s}{0.2 \cdot 1.0} \cdot 435 \cdot (1.2 \cdot 0.9 \cdot 1 + 0)$$

$$V_{Rdi} = 0.51 + \frac{a_s}{0.2} \cdot 469.56 = 2.1669$$

$$a_s = 7.07 \text{ cm}^2/\text{m}$$

### State II only shear force $V$ :

Design Load:

From the calculated inner lever arms for the two states we get a ratio:

$$\frac{z_I}{z_{II}} = 0.7664$$

The associated design shear flow  $V_{Edi}$  is:

$$V_{Edi} = 0.7664 \cdot 433.38 = 332.15 \text{ kN/m}$$

$$\text{and } v_{Edi} = 332.15/0.2 = 1.66 \text{ MPa}$$

Following the same calculation steps as for state II we have:

$$v_{Rd,c} = 0.20833 \text{ MPa (as above)}$$

$V_{Edi} > v_{Rd,c} \rightarrow$  shear reinforcement is required

$$V_{Edi} \leq V_{Rdi}$$

$$V_{Rdi} = c \cdot f_{ctd} + \mu \cdot \sigma_n + \rho \cdot f_{yd} \cdot (1.2 \cdot \mu \cdot \sin \alpha + \cos \alpha)$$

$$v_{Rdi} = 0.5 \cdot 1.02 + 0 + \frac{a_s}{0.2 \cdot 1.0} \cdot 435 \cdot (1.2 \cdot 0.9 \cdot 1 + 0)$$

$$v_{Rdi} = 0.51 + \frac{a_s}{0.2} \cdot 469.56 = 1.66$$

$$a_s = 4.90 \text{ cm}^2/\text{m}$$

**State II shear force  $V$  and moment  $M$ :**

$$M_{Eds} = 2250 \text{ kNm}$$

$$\mu_{Eds} = \frac{M_{Eds}}{b_{eff} \cdot d^2 \cdot f_{cd}} = \frac{2250 \cdot 10^{-3}}{2.5 \cdot 1.28^2 \cdot 14.17} = 0.03876$$

$$\omega = 0.03971 \text{ and } \xi = 0.9766 \text{ (interpolated)}$$

$$A_{s1} = \frac{1}{\sigma_{sd}} \cdot (\omega \cdot b \cdot d \cdot f_{cd} + N_{Ed}) = 39.44 \text{ cm}^2$$

$$z = \max \{d - c_{V,l} - 30 \text{ mm}; d - 2 c_{V,l}\}$$

$$z = \max \{1160; 1190\} = 1190 \text{ mm}$$

Design Load:

$$T_V = V / z = 800 / 1.19 = 672.268 \text{ kN/m}$$

$$T_V = 672.268 / 2 = 336.134 \text{ kN/m}$$

$$V_{Edi} = 336.134 \text{ kN/m}$$

$$\text{and } v_{Edi} = 336.134 / 0.2 = 1.68 \text{ MPa}$$

$$v_{Rd,c} = C_{Rd,c} \cdot k \cdot (100 \cdot \rho_1 \cdot f_{ck})^{1/3} + 0.12 \cdot \sigma_{cp}$$

$$C_{Rd,c} = 0.15 / \gamma_c = 0.1$$

$$k = 1 + \sqrt{\frac{200}{d}} = 1 + \sqrt{\frac{200}{1280}} = 1.3953 < 2.0$$

$$\rho_1 = \frac{A_{s1}}{b_w d} = \frac{39.44}{40 \cdot 128} = 0.007703 < 0.02$$

$$v_{Rd,c} = 0.1 \cdot 1.3953 \cdot (100 \cdot 0.007703 \cdot 25)^{1/3} + 0$$

$$v_{Rd,c} = 0.373229 \text{ MPa}$$

$v_{Edi} > v_{Rd,c} \rightarrow$  shear reinforcement is required

$$v_{Rdi} = c \cdot f_{ctd} + \mu \cdot \sigma_n + \rho \cdot f_{yd} \cdot (1.2 \cdot \mu \cdot \sin \alpha + \cos \alpha)$$

$$v_{Rdi} = 0.5 \cdot 1.02 + 0 + \frac{a_s}{0.2 \cdot 1.0} \cdot 435 \cdot (1.2 \cdot 0.9 \cdot 1 + 0)$$

$$v_{Rdi} = 0.51 + \frac{a_s}{0.2} \cdot 469.56 = 1.68$$

$$a_s = 4.99 \text{ cm}^2/\text{m}$$

Tab. 9.2 [3]:  $\omega$ —Table for up to C50/60 without compression reinforcement

$$N_{Ed} = 0$$

(NDP) 6.2.3 (1): Inner lever arm  $z$

The shear section with a length of 0.4 m is split into two equal parts with  $b_l = 0.2 \text{ m}$

(NDP) 6.2.2 (1):  $C_{Rd,c} = 0.15 / \gamma_c$

## 14.5 Conclusion

This example shows the calculation of the required reinforcement for a T-section under shear at the interface between concrete cast at different times. It has been shown that the results are reproduced with excellent accuracy. Small deviations occur because AQUA calculates (by using FEM analysis) the shear stresses more accurate compared to the reference example.

## 14.6 Literature

- [1] *DIN EN 1992-1-1/NA: Eurocode 2: Design of concrete structures, Part 1-1/NA: General rules and rules for buildings - German version EN 1992-1-1:2005 (D), Nationaler Anhang Deutschland - Stand Februar 2010.* CEN. 2010.
  - [2] F. Fingerloos, J. Hegger, and K. Zilch. *DIN EN 1992-1-1 Bemessung und Konstruktion von Stahlbeton- und Spannbetontragwerken - Teil 1-1: Allgemeine Bemessungsregeln und Regeln für den Hochbau.* BVPI, DBV, ISB, VBI. Ernst & Sohn, Beuth, 2012.
  - [3] K. Holschemacher, T. Müller, and F. Lobisch. *Bemessungshilfsmittel für Betonbauteile nach Eurocode 2 Bauingenieure.* 3rd. Ernst & Sohn, 2012.
  - [4] *Beispiele zur Bemessung nach Eurocode 2 - Band 1: Hochbau.* Ernst & Sohn. Deutschen Beton- und Bautechnik-Verein E.V. 2011.
-



## 15 DCE-EN12: Crack width calculation of reinforced beam acc. DIN EN 1992-1-1

### Overview

<b>Design Code Family(s):</b>	DIN
<b>Design Code(s):</b>	DIN EN 1992-1-1
<b>Module(s):</b>	AQB
<b>Input file(s):</b>	<a href="#">crack_widths.dat</a>

### 15.1 Problem Description

The problem consists of a rectangular section, asymmetrically reinforced, as shown in Fig. 15.1. Different loading conditions are examined, always consisting of a bending moment  $M_{Ed}$ , and in addition with or without a compressive or tensile axial force  $N_{Ed}$ . The crack width is determined.

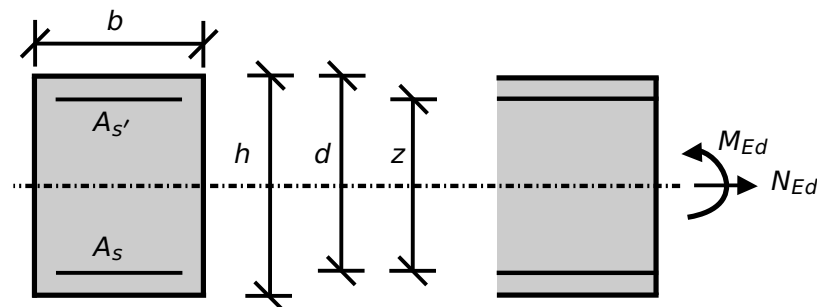

Figure 15.1: Problem Description

### 15.2 Reference Solution

This example is concerned with the control of crack widths. The content of this problem is covered by the following parts of DIN EN 1992-1-1:2004 [1]:

- Design stress-strain curves for concrete and reinforcement (Section 3.1.7, 3.2.7)
- Basic assumptions for calculation of crack widths (Section 7.3.2, 7.3.3, 7.3.4)

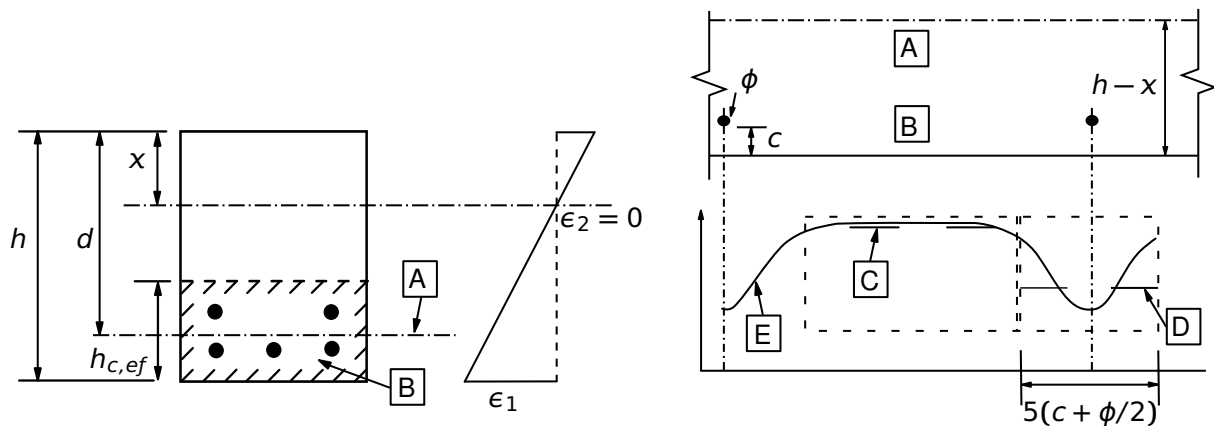

Figure 15.2: Stress and Strain Distributions in the Design of Cross-sections

The design stress-strain diagram for reinforcing steel considered in this example, consists of an inclined top branch, as defined in DIN EN 1992-1-1:2004 [1] (Section 3.2.7).

### 15.3 Model and Results

The rectangular cross-section, with properties as defined in Table 15.1, is to be designed for crack width, with respect to DIN EN 1992-1-1:2004 (German National Annex) [1] [2]. The calculation steps with different loading conditions and calculated with different sections of DIN EN 1992-1-1:2004 are presented below and the results are given in Table 15.2.

Table 15.1: Model Properties

Material Properties	Geometric Properties	Loading
C 25/30	$h = 100.0 \text{ cm}$	$N_{Ed} = 0 \text{ or } \pm 300 \text{ kN}$
B 500A	$d = 96.0 \text{ cm}$	$M_{Ed} = 562.5 \text{ kNm}$
	$b = 30.0 \text{ cm}$	
	$\phi_s = 25.0 \text{ mm}, A_s = 24.50 \text{ cm}^2$	
	$\phi_{s'} = 12.0 \text{ mm}, A_{s'} = 2.26 \text{ cm}^2$	
	$w_k = 0.3 \text{ mm}$	

Table 15.2: Results

Case	Load	$A_s$ given [ $\text{cm}^2$ ]	Result	SOF.	Ref.
I	$M_{Ed}, N_{Ed} = 0$	24.50	$A_{s,requ} [\text{cm}^2]$	6.93	6.93
			$\sigma_s [\text{MPa}]$	207.85	207.85
II	$M_{Ed}, N_{Ed} = 300$	24.50	$A_{s,requ} [\text{cm}^2]$	10.39	10.39
III	$M_{Ed}, N_{Ed} = -300$	24.50	$A_{s,requ} [\text{cm}^2]$	4.04	4.04

Table 15.2: (continued)

Case	Load	$A_s$ given [ $cm^2$ ]	Result	SOF.	Ref.
IV	$M_{Ed}, N_{Ed} = 0$	24.50	$A_s$ [ $cm^2$ ]	passed with given reinforcement	
			$\sigma_s$ [MPa]	440.57	440.53
V	$M_{Ed}, N_{Ed} = 0$	12.0	$A_s$ [ $cm^2$ ]	not passed with given reinforcement	
		→ new: 14.54	$\sigma_s$ [MPa]	436.30	436.28
VI	$M_{Ed}, N_{Ed} = 0$	24.50	$w_k$ [mm]	0.13	0.13

## 15.4 Design Process <sup>1</sup>

### Design with respect to DIN EN 1992-1-1:2004 (NA) [1] [2]:<sup>2</sup>

Material:

(NDP) 2.4.2.4: (1), Tab. 2.1DE: Partial factors for materials

Concrete:  $\gamma_c = 1.50$

Steel:  $\gamma_s = 1.15$

Tab. 3.1 : Strength for concrete

$f_{ck} = 25 \text{ MPa}$

3.1.6: (1)P, Eq. (3.15):  $\alpha_{cc} = 0.85$  considering long term effects

$f_{cd} = \alpha_{cc} \cdot f_{ck} / \gamma_c = 0.85 \cdot 25 / 1.5 = 14.17 \text{ MPa}$

3.2.2: (3)P: yield strength  $f_{yk} = 500 \text{ MPa}$

$f_{yk} = 500 \text{ MPa}$

3.2.7: (2), Fig. 3.8

$f_{yd} = f_{yk} / \gamma_s = 500 / 1.15 = 434.78 \text{ MPa}$

Design Load:

$M_{Ed} = 562.5 \text{ kNm}$

$N_{Ed} = 0.0 \text{ or } \pm 300 \text{ kN}$

7.3.2: If crack control is required, a minimum amount of bonded reinforcement is required to control cracking in areas where tension is expected

7.3.2 (2): Eq. 7.1:  $A_{s,min}$  minimum area of reinforcing steel within tensile zone

(NDP) 7.3.2 (2):  $f_{ct,eff}$  mean value of concrete tensile strength

When the cracking time can't be placed with certainty in the first 28 days then  $f_{ct,eff} \geq 3.0 \text{ MPa}$  for normal concrete

Tab. 3.1:  $f_{ctm} = 2.6 \text{ MPa}$  for C 25

7.3.2 (2):  $A_{ct}$  is the area of concrete within tensile zone, for pure bending of a rectangular section its height is  $h/2$

#### Minimum reinforcement areas

- Case I:  $M_{Ed}, N_{Ed} = 0.0$

$A_{s,min} \cdot \sigma_s = k_c \cdot k \cdot f_{ct,eff} \cdot A_{ct}$

$f_{ct,eff} = f_{ctm} \geq 3.0 \text{ MPa}$

$f_{ct,eff} = 2.6 < 3.0 \text{ MPa} \rightarrow f_{ct,eff} = 3.0 \text{ MPa}$

$A_{ct} = b \cdot h_{eff} = 0.3 \cdot 0.5 = 0.15 \text{ m}^2$

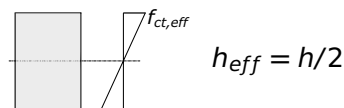

7.3.2 (2): Eq. 7.2:  $k_c$  for bending of rectangular sections

$$k_c = 0.4 \cdot \left[ 1 - \frac{\sigma_c}{k_1 \cdot (h/h^*) \cdot f_{ct,eff}} \right] \leq 1$$

7.3.2 (2): Eq. 7.4:  $\sigma_c$  mean stress of the concrete

$\sigma_c = N_{Ed} / (b \cdot h) = 0.0 \rightarrow k_c = 0.4$

7.3.2 (2):  $h$  is the lesser value of  $b, h$   
 $h = \min \{300, 1000\} = 300 \text{ mm}$

$k = 0.8$  for  $h \leq 300$

7.3.2 (NA.5): Eq. NA.7.5.2: For determination of the reinforcement stress the maximum bar diameter has to be modified

$\phi_s = \phi_s^* \cdot f_{ct,eff} / 2.9 \text{ N/mm}^2$

$\phi_s^* = 25 \cdot 2.9 / 3.0 = 24.16667$

<sup>1</sup>The tools used in the design process are based on steel stress-strain diagrams, as defined in [1] 3.2.7:(2), Fig. 3.8.

<sup>2</sup>The sections mentioned in the margins refer to DIN EN 1992-1-1:2004 (German National Annex) [1], [2], unless otherwise specified.

$$\sigma_s = \sqrt{w_k \cdot 3.48 \cdot 10^6 / \phi_s^*} = 207.846 \text{ MPa}$$

(NDP) 7.3.3 Tab. 7.2DE (a)  
where  $w_k = 0.3 \text{ m}$  the prescribed maximum crack width

$$A_{s,requ} = 0.4 \cdot 0.8 \cdot 3.0 \cdot 0.15 \cdot 10^4 / 207.846 = 6.928 \text{ cm}^2$$

- Case II:  $N_{Ed} = 300 \text{ kN}$

$$A_{s,min} \cdot \sigma_s = k_c \cdot k \cdot f_{ct,eff} \cdot A_{ct}$$

7.3.2 (2): Eq. 7.1:  $A_{s,min}$  minimum area of reinforcing steel within tensile zone

$$f_{ct,eff} = f_{ctm} \geq 3.0 \text{ MPa}$$

$$f_{ct,eff} = 2.6 < 3.0 \text{ MPa} \rightarrow f_{ct,eff} = 3.0 \text{ MPa}$$

Tab. 3.1:  $f_{ctm} = 2.6 \text{ MPa}$  for C 25

$$A_{ct} = b \cdot h_{eff} = 0.15 \text{ m}^2$$

7.3.2 (2):  $A_{ct}$  is the area of concrete within tensile zone

$$\sigma_c = \frac{N_{Ed}}{b \cdot h} = \frac{300 \cdot 10^3}{300 \cdot 1000} = 1.0 \text{ MPa}$$

7.3.2 (2): Eq. 7.4:  $\sigma_c$  mean stress of the concrete, tensile stress  $\sigma_c < 0$

$$k = 0.8 \text{ for } h \leq 300$$

7.3.2 (2):  $h$  is the lesser value of  $b, h$   
 $h = \min \{300, 1000\} = 300 \text{ mm}$

$$\phi_s = \phi_s^* \cdot f_{ct,eff} / 2.9 \text{ N/mm}^2$$

(NDP) 7.3.2 (NA.5): Eq. NA.7.5.2: For determination of the reinforcement stress the maximum bar diameter has to be modified

$$\phi_s^* = 25 \cdot 2.9 / 3.0 = 24.16667$$

$$\sigma_s = \sqrt{w_k \cdot 3.48 \cdot 10^6 / \phi_s^*} = 207.846 \text{ MPa}$$

(NDP) 7.3.3 Tab. 7.2DE (a)  
where  $w_k = 0.3 \text{ m}$  the prescribed maximum crack width

$$k_c = 0.4 \cdot \left[ 1 - \frac{\sigma_c}{k_1 \cdot (h/h^*) \cdot f_{ct,eff}} \right] \leq 1$$

7.3.2 (2): Eq. 7.2:  $k_c$  for bending with axial force of rectangular sections

$$k_1 = 2 \cdot h^* / (3 \cdot h) = 2/3$$

$h^* = 1.0 \text{ m}$  for  $h \geq 1.0 \text{ m}$

$$k_c = 0.4 \cdot \left[ 1 + \frac{1.0}{(2/3) \cdot 1 \cdot 3.0} \right] = 0.6 \leq 1$$

$k_1 = 2 \cdot h^* / (3 \cdot h)$  if  $N_{Ed}$  tensile force

7.3.2 (2): Eq. 7.1: Tensile stress  $\sigma_c < 0$

$$A_{s,requ} = 0.6 \cdot 0.8 \cdot 3.0 \cdot 0.15 \cdot 10^4 / 207.846 = 10.39 \text{ cm}^2$$

- Case III:  $N_{Ed} = -300 \text{ kN}$

$$A_{s,min} \cdot \sigma_s = k_c \cdot k \cdot f_{ct,eff} \cdot A_{ct}$$

7.3.2 (2): Eq. 7.1:  $A_{s,min}$  minimum area of reinforcing steel within tensile zone

$$f_{ct,eff} = f_{ctm} \geq 3.0 \text{ MPa}$$

$$f_{ct,eff} = 2.6 < 3.0 \text{ MPa} \rightarrow f_{ct,eff} = 3.0 \text{ MPa}$$

Tab. 3.1:  $f_{ctm} = 2.6 \text{ MPa}$  for C 25

$$A_{ct} = b \cdot h_{eff}$$

7.3.2 (2):  $A_{ct}$  is the area of concrete within tensile zone

The height of the tensile zone is determined through the stresses:

$$\sigma_c = \frac{N_{Ed}}{b \cdot h} = \frac{300 \cdot 10^3}{300 \cdot 1000} = 1.0 \text{ MPa}$$

7.3.2 (2): Eq. 7.4:  $\sigma_c$  mean stress of the concrete, compressive stress  $\sigma_c > 0$

$$\sigma_u = f_{ct,eff} = 3.0 \text{ MPa}$$

$$\Rightarrow h_{eff} = \frac{3.0 \cdot 50}{3.0 + 1.0} = 37.5 \text{ cm}$$

$$A_{ct} = 0.3 \cdot 0.375 = 0.1125 \text{ m}^2$$

$$k = 0.8 \text{ for } h \leq 300$$

7.3.2 (2):  $h$  is the lesser value of  $b, h$   
 $h = \min \{300, 1000\} = 300 \text{ mm}$

(NDP) 7.3.2 (NA.5): Eq. NA.7.5.2: For determination of the reinforcement stress the maximum bar diameter has to be modified

(NDP) 7.3.3 Tab. 7.2DE (a)  
 where  $w_k = 0.3 m$  the prescribed maximum crack width  
 7.3.2 (2): Eq. 7.2:  $k_c$  for bending with axial force of rectangular sections

$h^* = 1.0 m$  for  $h \geq 1.0 m$   
 $k_1 = 1.5$  if  $N_{Ed}$  compressive force

$$\phi_s = \phi_s^* \cdot f_{ct,eff} / 2.9 \text{ N/mm}^2$$

$$\phi_s^* = 25 \cdot 2.9 / 3.0 = 24.16667$$

$$\sigma_s = \sqrt{w_k \cdot 3.48 \cdot 10^6 / \phi_s^*} = 207.846 \text{ MPa}$$

$$k_c = 0.4 \cdot \left[ 1 - \frac{\sigma_c}{k_1 \cdot (h/h^*) \cdot f_{ct,eff}} \right] \leq 1$$

$$k_1 = 1.5$$

$$k_c = 0.4 \cdot \left[ 1 - \frac{1.0}{1.5 \cdot 1 \cdot 3.0} \right] = 0.3111 \leq 1$$

$$A_{s,requ} = 0.3111 \cdot 0.8 \cdot 3.0 \cdot 0.1125 \cdot 10^4 / 207.846 = 4.04 \text{ cm}^2$$

7.3.3: Control of cracking without direct calculation

Examples calculated in this section are w.r.t. Table 7.2DE, here Table 7.3N is not relevant

(NDP) 7.3.2 (2):  $f_{ct,eff}$  mean value of concrete tensile strength

Tab. 3.1:  $f_{ctm} = 2.6 \text{ MPa}$  for C 25

(NDP) 7.3.3: Eq. 7.7.1DE: The maximum bar diameters should be modified for load action

$A_s = 24.5 \text{ cm}^2$  prescribed reinforcement

### Control of cracking without direct calculation

- Case IV:  $N_{Ed} = 0.0$

$$f_{ct,eff} = f_{ctm} \geq 3.0 \text{ MPa}$$

$$f_{ct,eff} = 2.6 < 3.0 \text{ MPa} \rightarrow f_{ct,eff} = 3.0 \text{ MPa}$$

$$\phi_s = \phi_s^* \cdot \frac{\sigma_s \cdot A_s}{4(h-d) \cdot b \cdot 2.9} \geq \phi_s^* \cdot \frac{f_{ct,eff}}{2.9}$$

$$\phi_s = 25 \text{ mm} = \phi_s^* \cdot \frac{264.06 \cdot 24.50}{4(100-96) \cdot 30 \cdot 2.9} = \phi_s^* \cdot 4.6476$$

$$\rightarrow \phi_s^* = 5.3791 \text{ mm}$$

$$\sigma_s = \sqrt{w_k \cdot 3.48 \cdot 10^6 / \phi_s^*} = 440.53 \text{ MPa}$$

$$\sigma_s = 264.06 < 440.53 \text{ MPa}$$

which corresponds to the value calculated in SOFiSTiK [ssr]

$\rightarrow$  crack width control is passed with given reinforcement.

In case the usage factor becomes 1.0 then the stresses  $\sigma_s$  are equal, as it can be seen in Case V below.

$$\text{and } \phi_s = 25 \text{ mm} > \phi_s^* \cdot \frac{f_{ct,eff}}{2.9} = 5.3791 \cdot \frac{3.0}{2.9} = 5.5646$$

also control the steel stress with respect to the calculated strains

$$\epsilon_s = 0.440 + 1.913 \cdot (0.50 - 0.04) = 1.31998$$

$$\rightarrow \sigma_s = 0.00131998 \cdot 200000 = 264.0 \text{ MPa}$$

or

(NDP) 7.3.3 Tab. 7.2DE (a)

from Tab. 7.2DE and for  $\sigma_s = 264.04 \approx 260.0 \text{ MPa}$

(NDP) 7.3.3: Eq. 7.7.1DE: The maximum bar diameters should be modified for load action

$$\rightarrow \phi_s^* = 15 \text{ mm} \rightarrow \phi_s = \phi_s^* \cdot \frac{\sigma_s \cdot A_s}{4(h-d) \cdot b \cdot 2.9} \geq \phi_s^* \cdot \frac{f_{ct,eff}}{2.9}$$

$$\phi_s = 15 \cdot \frac{264.06 \cdot 24.50}{4(100 - 96) \cdot 30 \cdot 2.9} = 69.69 \text{ mm} > 25 \text{ mm}$$

→ crack width control is passed with given reinforcement.

- Case V:  $N_{Ed} = 0.0$ ,  $A_s = 12.0 \text{ cm}^2$

In this case, the prescribed reinforcement is decreased from  $A_s = 24.5 \text{ cm}^2$  to  $A_s = 12.0 \text{ cm}^2$  in order to examine a case where the crack width control is not passed with the given reinforcement.

$$f_{ct,eff} = f_{ctm} \geq 3.0 \text{ MPa}$$

$$f_{ct,eff} = 2.6 < 3.0 \text{ MPa} \rightarrow f_{ct,eff} = 3.0 \text{ MPa}$$

from Tab. 7.2DE and for  $\sigma_s = 509.15 \approx 510.0 \text{ MPa}$

$$\rightarrow \phi_s^* \approx 3.9 \text{ mm} \rightarrow \phi_s = \phi_s^* \cdot \frac{\sigma_s \cdot A_s}{4(h-d) \cdot b \cdot 2.9}$$

$$\phi_s = 3.9 \cdot \frac{509.15 \cdot 12.0}{4(100 - 96) \cdot 30 \cdot 2.9} = 17.12 \text{ mm} < 25 \text{ mm}$$

→ crack width control is not passed with given reinforcement.

→ start increasing reinforcement in order to be in the limits of admissible steel stresses

from Tab. 7.2DE and for  $\sigma_s = 436.43 \text{ MPa}$

$$\rightarrow \phi_s^* \approx 5.6 \text{ mm} \rightarrow \phi_s = \phi_s^* \cdot \frac{\sigma_s \cdot A_s}{4(h-d) \cdot b \cdot 2.9}$$

$$\phi_s = 5.6 \cdot \frac{436.43 \cdot 14.54}{4(100 - 96) \cdot 30 \cdot 2.9} = 25.45 \text{ mm} \geq 25 \text{ mm}$$

→ crack width control passed with additional reinforcement.

If we now input as prescribed reinforcement the reinforcement that is calculated in order to pass crack control, i.e.  $A_s = 14.54 \text{ cm}^2$  we get a steel stress of  $\sigma_s = 436.36 \text{ MPa}$  which gives

$$\phi_s = 25 \text{ mm} = \phi_s^* \cdot \frac{436.36 \cdot 14.54}{4(100 - 96) \cdot 30 \cdot 2.9}$$

$$\rightarrow \phi_s^* = 5.4849 \text{ mm}$$

$$\sigma_s = \sqrt{w_k \cdot 3.48 \cdot 10^6 / \phi_s^*}$$

$$\sigma_s = \sqrt{0.3 \cdot 3.48 \cdot 10^6 / 5.4849} = 436.28 \text{ MPa}$$

Here we can notice that the stresses are equal leading to a usage factor of 1.0

(NDP) 7.3.2 (2):  $f_{ct,eff}$  mean value of concrete tensile strength

Tab. 3.1:  $f_{ctm} = 2.6 \text{ MPa}$  for C 25

(NDP) 7.3.3 Tab. 7.2DE (a)

(NDP) 7.3.3: Eq. 7.7.1DE: The maximum bar diameters should be modified for load action

(NDP) 7.3.3 Tab. 7.2DE (a)

7.3.3: Eq. 7.7.1DE: The maximum bar diameters should be modified for load action

(NDP) 7.3.3 Tab. 7.2DE (a)  
where  $w_k = 0.3 \text{ mm}$  the prescribed maximum crack width

### Control of cracking with direct

#### calculation

7.3.4: Control of cracking with direct calculation

- Case VI:  $N_{Ed} = 0.0$

7.3.4 (1):  $\alpha_e$  is the ratio  $E_s / E_{cm}$

$$\alpha_e = E_s / E_{cm} = 200000 / 31476 = 6.354$$

7.3.4 (1): Eq. 7.10: where  $A'_p$  and  $A_{c,eff}$  are defined in 7.3.2 (3)

$$\rho_{p,eff} = (A_s + \xi_1^2 \cdot A'_p) / A_{c,eff}$$

7.3.2 (3):  $h_{c,ef}$  see Fig. 7.1DE (d)

$$A_{c,eff} = h_{c,ef} \cdot b$$

$$h / d_1 = 100/4 = 25.00 \rightarrow h_{c,ef} / d_1 = 3.25$$

$$A_{c,eff} = (3.25 \cdot 4) \cdot 30 = 13 \cdot 30 = 390 \text{ cm}^2$$

7.3.2 (3): where  $A'_p$  is the area of pre or post-tensioned tendons within  $A_{c,eff}$

$$A'_p = 0.0 \text{ cm}^2$$

$$\rho_{p,eff} = 24.50 / 390 = 0.06282$$

7.3.4 (1): Eq. 7.9: the difference of the mean strain in the reinforcement and in the concrete

$$\epsilon_{sm} - \epsilon_{cm} = \frac{\sigma_s - k_t \cdot \frac{f_{ct,eff}}{\rho_{p,eff}} \cdot (1 + \alpha_e \cdot \rho_{p,eff})}{E_s} \geq 0.6 \cdot \frac{\sigma_s}{E_s}$$

(NDP) 7.3.2 (2):  $f_{ct,eff}$  mean value of concrete tensile strength, here no minimum value of  $f_{ct,eff} \geq 3.0 \text{ MPa}$  is set  
Tab. 3.1:  $f_{ctm} = 2.6 \text{ MPa}$  for C 25 or  $f_{ctm} = 0.30 \cdot f_{ck}^{2/3} = 2.565 \text{ MPa}$

$$f_{ct,eff} = f_{ctm} = 0.30 \cdot f_{ck}^{2/3} = 2.565 \approx 2.6 \text{ MPa}$$

$$f_{ct,eff} = 2.6 < 3.0 \text{ MPa} \rightarrow f_{ct,eff} = 3.0 \text{ MPa}$$

$k_t$ : factor dependent on the duration of the load,  $k_t = 0.4$  for long term loading

$$\epsilon_{sm} - \epsilon_{cm} = \frac{264.06 - 0.4 \cdot \frac{2.565}{0.06282} \cdot (1 + 6.354 \cdot 0.06282)}{200000}$$

$$\epsilon_{sm} - \epsilon_{cm} = 1.2060 \cdot 10^{-3} > 0.6 \cdot \frac{264.06}{200000} = 0.79218 \cdot 10^{-3}$$

(NDP) 7.3.4 (3): Eq. 7.11:  $s_{r,max}$  is the maximum crack spacing

$$s_{r,max} = \frac{\phi}{3.6 \cdot \rho_{p,eff}} \leq \frac{\sigma_s \cdot \phi}{3.6 \cdot f_{ct,eff}}$$

$$s_{r,max} = \frac{25}{3.6 \cdot 0.06282} = 110.545 \text{ mm}$$

$$s_{r,max} \leq \frac{\sigma_s \cdot \phi}{3.6 \cdot f_{ct,eff}} = 611.25 \text{ mm}$$

7.3.4 (1): Eq. 7.8:  $w_k$  the crack width

$$w_k = s_{r,max} \cdot (\epsilon_{sm} - \epsilon_{cm}) = 110.545 \cdot 1.2060 \cdot 10^{-3}$$

$w_k = 0.133 < 0.3 \text{ mm} \rightarrow$  Check for crack width passed with given reinforcements

### Stress limitation

7.2 (5)

$$\sigma_{max,t} = k_3 \cdot f_{yk}$$

$$\sigma_{max,t} = 0.80 \cdot 500 \text{ MPa}$$

$$\sigma_{max,t} = 400 \text{ MPa}$$



## 15.5 Conclusion

This example shows the calculation of crack widths. Various ways of reference calculations are demonstrated, in order to compare the SOFiSTiK results to. It has been shown that the results are reproduced with excellent accuracy.

## 15.6 Literature

- [1] *DIN EN 1992-1-1/NA: Eurocode 2: Design of concrete structures, Part 1-1/NA: General rules and rules for buildings - German version EN 1992-1-1:2005 (D), Nationaler Anhang Deutschland - Stand Februar 2010.* CEN. 2010.
  - [2] F. Fingerloos, J. Hegger, and K. Zilch. *DIN EN 1992-1-1 Bemessung und Konstruktion von Stahlbeton- und Spannbetontragwerken - Teil 1-1: Allgemeine Bemessungsregeln und Regeln für den Hochbau.* BVPI, DBV, ISB, VBI. Ernst & Sohn, Beuth, 2012.
-



## 16 DCE-EN13: Design of a Steel I-section for Bending and Shear

### Overview

<b>Design Code Family(s):</b>	EN
<b>Design Code(s):</b>	EN 1993-1-1
<b>Module(s):</b>	AQB, AQUA
<b>Input file(s):</b>	<a href="#">usage_steel.dat</a>

### 16.1 Problem Description

The problem consists of a steel I-section, as shown in Fig. 16.1. The cross-section is designed for bending and shear.

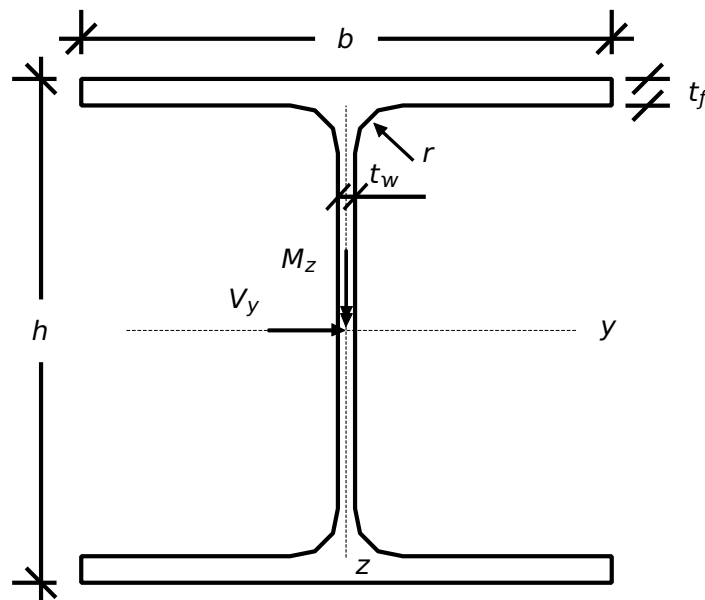

Figure 16.1: Problem Description

### 16.2 Reference Solution

This example is concerned with the resistance of steel cross-sections for bending and shear. The content of this problem is covered by the following parts of EN 1993-1-1:2005 [7]:

- Structural steel (Section 3.2 )
- Resistance of cross-sections (Section 6.2)

### 16.3 Model and Results

The I-section, a HEA 200, with properties as defined in Table 16.1, is to be designed for an ultimate moment  $M_z$  and a shear force  $V_y$ , with respect to EN 1993-1-1:2005 [7]. The calculation steps are

presented below and the results are given in Table 16.2. The utilisation level of allowable plastic forces are calculated and compared to SOFiSTiK results.

Table 16.1: Model Properties

Material Properties	Geometric Properties	Loading
S 235	HEA 200 $b = 20.0 \text{ cm}$ $h = 19.0 \text{ cm}$ $t_f = 1.0 \text{ cm}, t_w = 0.65 \text{ cm}$ $r = 1.8 \text{ cm}$	$V_y = 200 \text{ or } 300 \text{ kN}$ $M_z = 20 \text{ kNm}$

Table 16.2: Results

Case	Result	SOF. (EC3 Tables)	SOF. (FEM)	Ref.
	$V_{pl,Rd,y} \text{ [kN]}$	542.71	611.42	542.71
	$V_{pl,Rd,z} \text{ [kN]}$	245.32	228.67	245.32
<i>I</i>	Util. level $V_y$	0.369	0.327	0.369
	Util. level $M_z$	0.418	0.418	0.418
<i>II</i>	Util. level $V_y$	0.553	0.491	0.553
	Util. level $M_z$	0.418	0.418	0.418

## 16.4 Design Process<sup>1</sup>

Material:

Structural Steel S 235

$$f_y = 235 \text{ N/mm}^2$$

Cross-sectional properties:

$$W_{pl,y} = 429.5 \text{ cm}^3$$

$$W_{pl,z} = 203.8 \text{ cm}^3$$

Tab. 3.1 : Nominal values of yield strength  $f_y$  and ultimate tensile strength  $f_u$  for hot rolled structural steel.

Plastic section modulus of HEA 200 w.r.t. y- and z-axis

Where the shear force is present allowance should be made for its effect on the moment resistance. This effect may be neglected, where the shear force is less than half the plastic shear resistance.

6.2.8: Bending and shear

$$V_{Ed} \leq 0.5 V_{pl,Rd}$$

6.2.8 (2)

$$V_{pl,Rd} = \frac{A_V \cdot (f_y / \sqrt{3})}{\gamma_{M0}}$$

6.2.6 (2): Eq. 6.18:  $V_{pl,Rd}$  the design plastic shear resistance

$$A_{V_y} = 2 \cdot A_{flange} \text{ (in the } y\text{-direction only contribution the two flanges)}$$

$A_V$  the shear area w.r.t. y- and z-axis, respectively

$$A_{V_y} = 2 \cdot t_f \cdot b = 2 \cdot 1 \cdot 20 = 40 \text{ cm}^2$$

$$A_{V_z} = A - 2 \cdot b \cdot t_f + (t_w + 2 \cdot r) \cdot t_f \text{ but not less than } \eta \cdot h_w \cdot t_w$$

$$A_{V_z} = 53.8 - 2 \cdot 20 \cdot 1 + (0.65 + 2 \cdot 1.8) \cdot 1$$

6.2.6 (3): The shear area  $A_V$  may be taken as follows for rolled I-sections with load parallel to the web

$$h_w = h - 2 \cdot t_f = 17 \text{ cm}$$

$$A_{V_z} = 18.08 \text{ cm}^2 > 1 \cdot 17 \cdot 0.65 = 11.05$$

6.2.6 (3):  $\eta$  may be conservatively taken equal to 1.0

$$V_{pl,Rd,y} = \frac{40 \cdot (23.5 / \sqrt{3})}{1.00} = 542.70 \text{ kN}$$

6.1 (1): Partial factor  $\gamma_{M0} = 1.00$  is recommended

$$V_{pl,Rd,z} = \frac{18.08 \cdot (23.5 / \sqrt{3})}{1.00} = 245.30 \text{ kN}$$

### a) Finite Element Method:

#### • Case I:

According to FEM analysis:

$$V_{pl,Rd,y} = 611.85 \text{ kN}$$

$$V_{pl,Rd,z} = 228.38 \text{ kN}$$

we have:

$$V_{Ed} = V_y = 200 \text{ kN}, M_z = 20 \text{ kNm}$$

<sup>1</sup>The sections mentioned in the margins refer to EN 1993-1-1:2005 [7] unless otherwise specified.

$$\frac{V_{Ed}}{V_{pl,Rd,y}} = \frac{200}{611.85} = 0.3268 < 0.5$$

→ no reduction of moment resistance due to shear

6.2.8 (5): Eq. 6.30: The reduced design plastic resistance moment (for  $\rho = 0$ )

$$M_{z,V,Rd} = \frac{W_{pl,z} \cdot f_y}{\gamma_{M0}} = \frac{203.8 \cdot 23.5}{1} = 4789 \text{ kNcm} = 47.89 \text{ kNm}$$

$$\frac{M_z}{M_{z,V,Rd}} = \frac{20}{47.89} = 0.418$$

• **Case II:**

$$V_{Ed} = V_y = 300 \text{ kN}, M_z = 20 \text{ kNm}$$

$$\frac{V_{Ed}}{V_{pl,Rd,y}} = \frac{300}{611.85} = 0.490 < 0.5$$

→ no reduction of moment resistance due to shear

$$M_{z,V,Rd} = \frac{W_{pl,z} \cdot f_y}{\gamma_{M0}}$$

$$M_{z,V,Rd} = 47.89 \text{ kNm}$$

$$\frac{M_z}{M_{z,V,Rd}} = \frac{20}{47.89} = 0.418$$

**b) EC3 Tables:**

$$V_{pl,Rd,y} = 542.71 \text{ kN}$$

$$V_{pl,Rd,z} = 245.32 \text{ kN}$$

• **Case I:**

$$V_{Ed} = V_y = 200 \text{ kN}, M_z = 20 \text{ kNm}$$

$$\frac{V_{Ed}}{V_{pl,Rd,y}} = \frac{200}{542.71} = 0.368 < 0.5$$

→ no reduction of moment resistance due to shear

6.2.8 (5): Eq. 6.30: The reduced design plastic resistance moment (for  $\rho = 0$ )

$$M_{z,V,Rd} = \frac{W_{pl,z} \cdot f_y}{\gamma_{M0}} = \frac{203.8 \cdot 23.5}{1} = 4789 \text{ kNcm} = 47.89 \text{ kNm}$$

$$\frac{M_z}{M_{z,V,Rd}} = \frac{20}{47.89} = 0.418$$

• **Case II:**

$$V_{Ed} = V_y = 300 \text{ kN}, M_z = 20 \text{ kNm}$$

$$\frac{V_{Ed}}{V_{pl,Rd,y}} = \frac{300}{542.71} = 0.552 > 0.5$$

6.2.8 (3): The reduced moment resistance should be taken as the design resistance of the cross-section, calculated using a reduced yield strength  $(1 - \rho) \cdot f_y$  for the shear area

→ reduction of moment resistance due to shear

$$\begin{aligned}\rho &= \left( \frac{2 \cdot V_{Ed}}{V_{pl,Rd,y}} - 1 \right)^2 \\ &= \left( \frac{2 \cdot 300}{542.71} - 1 \right)^2 \\ &= 0.011143\end{aligned}$$

$$M_{z,V,Rd} = (1 - \rho) \cdot \frac{W_{pl,z} \cdot f_y}{\gamma_{M0}}$$

$$M_{z,V,Rd} = (1 - 0.0111435) \cdot 47.89 = 47.35 \text{ kNm}$$

$$\frac{M_z}{M_{z,V,Rd}} = \frac{20}{47.356} = 0.4223$$

## 16.5 Conclusion

This example shows the calculation of the resistance of steel cross-section for bending and shear. It has been shown that the results are reproduced with excellent accuracy.

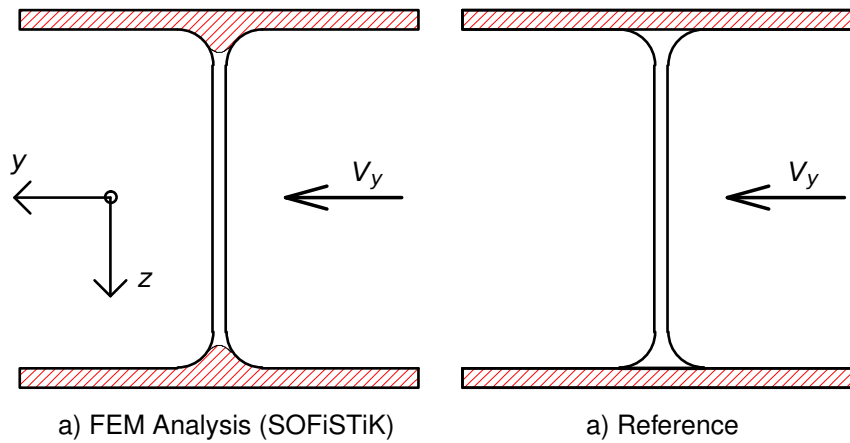

Figure 16.2: Visualisation of areas and approach for calculating the  $V_{pl,Rd,y}$

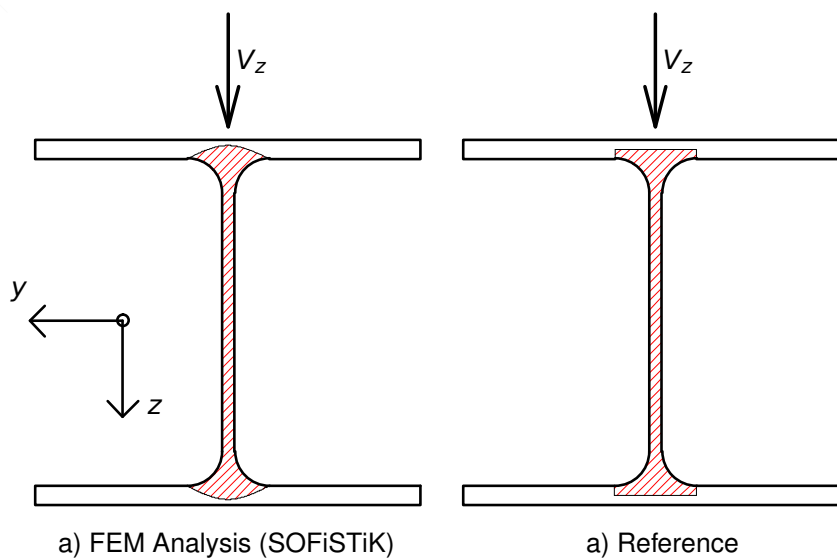
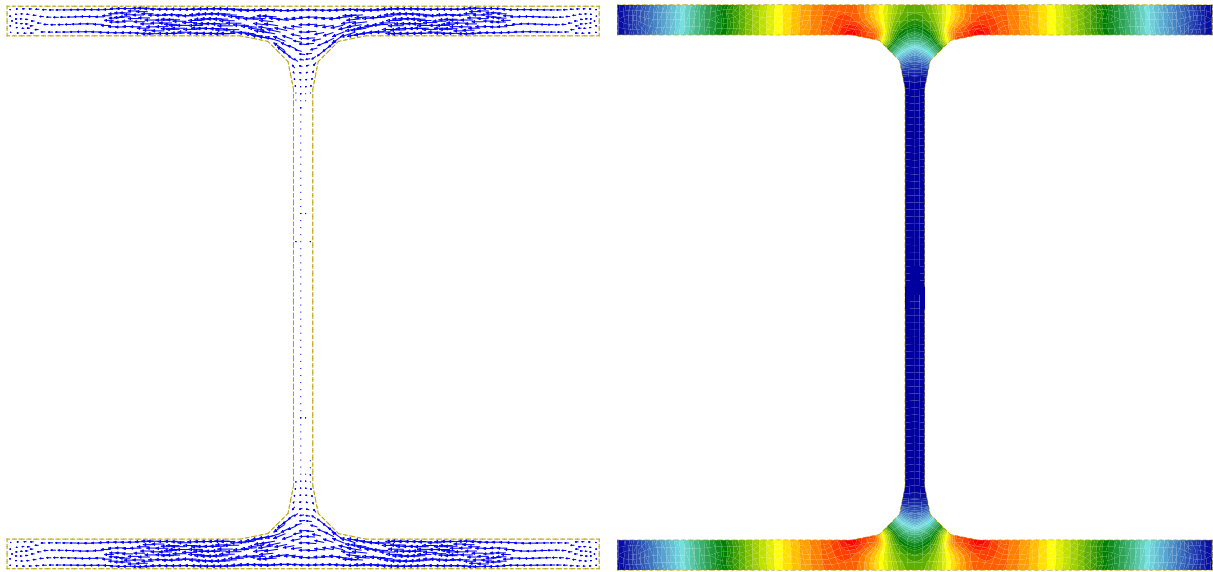
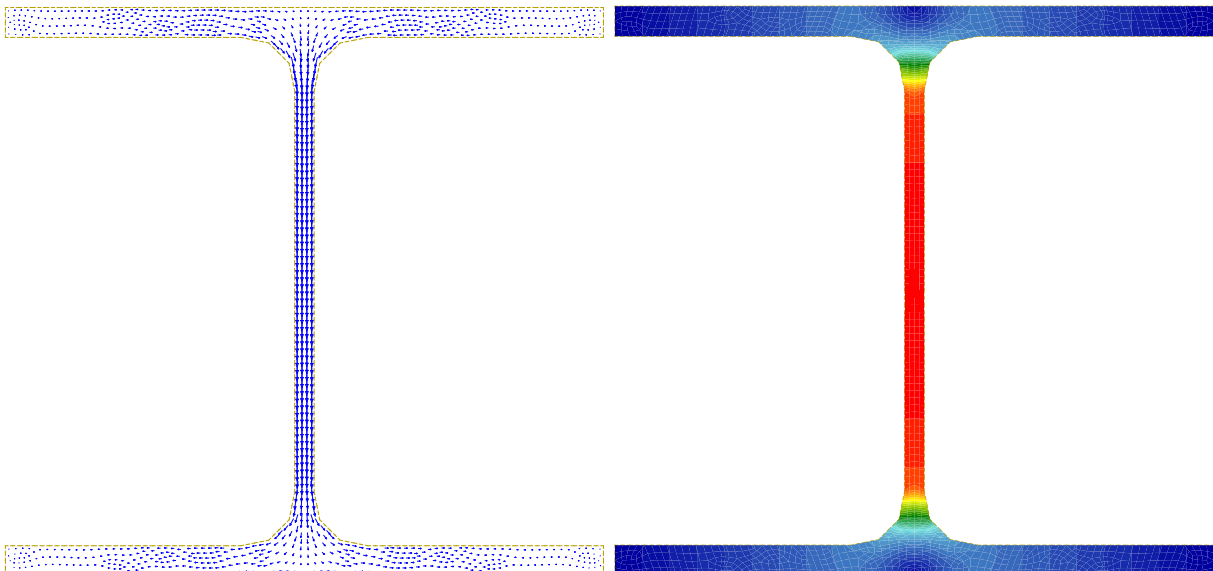

Figure 16.3: Visualisation of areas and approach for calculating the  $V_{pl,Rd,z}$

By using FEM analysis the  $V_{pl,Rd,y}$  and  $V_{pl,Rd,z}$  values are deviating from the reference values. The reason behind this difference is shown in Fig. 16.2, 16.3, 16.4 and 16.5.

FEM analysis represents a real physical behaviour, because as shown in Fig. 16.2 and 16.3 the calculated area is taken approximately for the reference  $V_{pl,Rd,y}$  and  $V_{pl,Rd,z}$  values. The results by using FEM analysis are more accurate in reality than the reference example.



Figure 16.4:  $V_{pl,Rd,y}$  - SOFiSTiK Results (FEM)Figure 16.5:  $V_{pl,Rd,z}$  - SOFiSTiK Results (FEM)

## 16.6 Literature

- [7] EN 1993-1-1: Eurocode 3: Design of concrete structures, Part 1-1: General rules and rules for buildings. CEN. 2005.
- [8] Schneider. *Bautabellen für Ingenieure*. 21th. Bundesanzeiger Verlag, 2014.



## 17 DCE-EN14: Classification of Steel Cross-sections

### Overview

<b>Design Code Family(s):</b>	EN
<b>Design Code(s):</b>	EN 1993-1-1
<b>Module(s):</b>	AQB
<b>Input file(s):</b>	<a href="#">class.steel.dat</a>

### 17.1 Problem Description

The problem consists of a steel I-section, as shown in Fig. 17.1. The cross-section is classified for bending and compression.

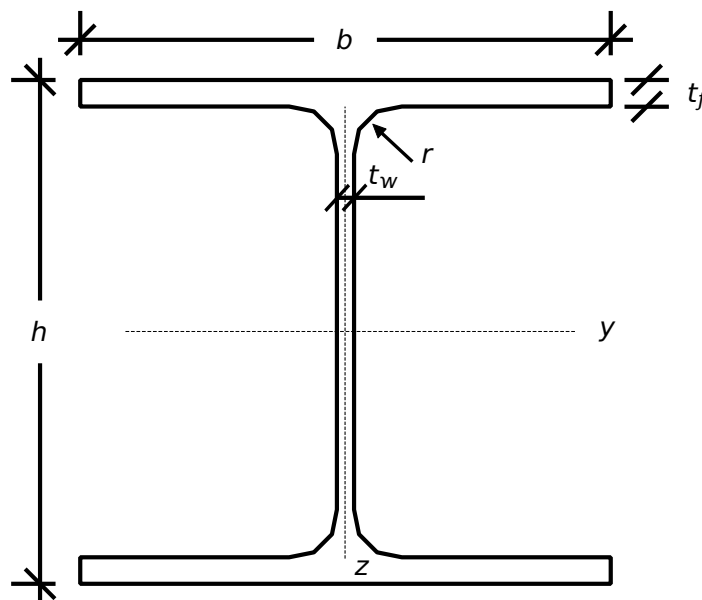

Figure 17.1: Problem Description

### 17.2 Reference Solution

This example is concerned with the classification of steel cross-sections. Section classification is a vital step in checking the suitability of a section to sustain any given design actions. It is concerned with the local buckling susceptibility and is involved on the resistance checks of the section. The content of this problem is covered by the following parts of EN 1993-1-1:2004 [7]:

- Structural steel (Section 3.2 )
- Classification of cross-sections (Section 5.5)
- Cross-section requirements for plastic global analysis (Section 5.6)
- Resistance of cross-sections (Section 6.2)
- Buckling resistance of members (Section 6.3)

A diagrammatic representation of the four classes of section is given in Fig. 17.2, where a cross-section is subjected to an increasing major axis bending moment until failure [9].

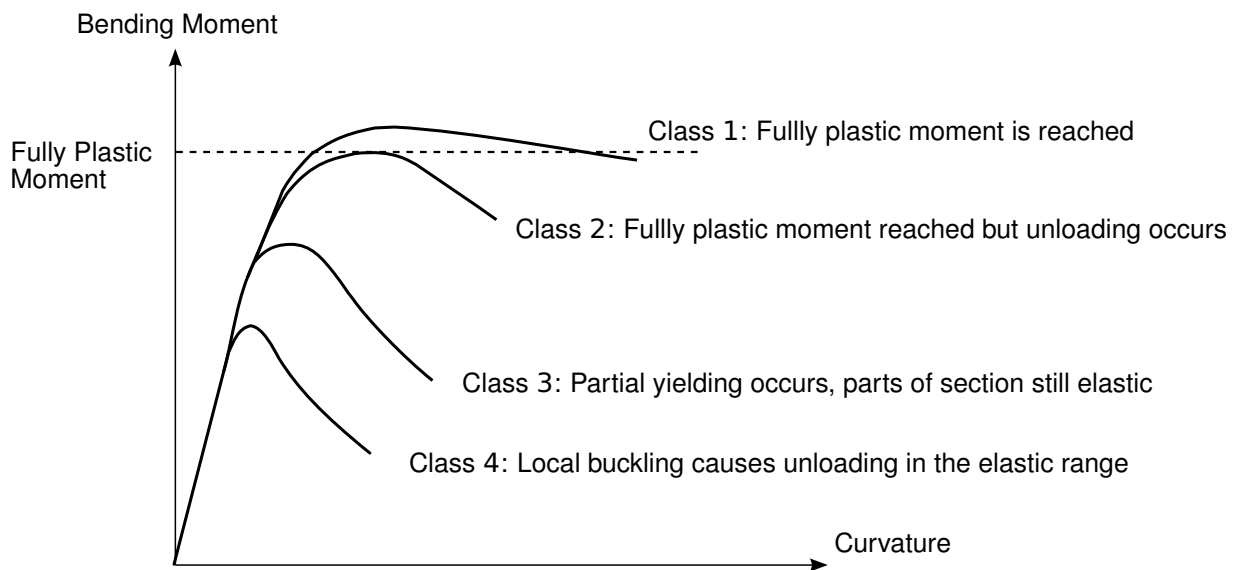

Figure 17.2: Idealized Moment Curvature Behaviour for Four Classes of Cross-sections

### 17.3 Model and Results

The I-section, a UB 457x152x74, with properties as defined in Table 17.1, is to be classified for bending and compression, with respect to EN 1993-1-1:2005 [7]. For the compression case, an axial load of  $N = 3000 \text{ kN}$  is applied and for the bending case a moment of  $M_y = 500 \text{ kNm}$ . In **AQB** the classification of the cross-sections is done taking into account the stress levels and the respective design request. Thus, a Class 1 cross-section can be reached, only if a nonlinear design (plastic-plastic) is requested and if the loading is such as to cause the yield stress to be exceeded. Therefore, in order to derive the higher Class possible for this cross-section, we consider these loads, which will cause higher stresses than the yield stress. The calculation steps are presented below and the results are given in Table 17.2.

Table 17.1: Model Properties

Material Properties	Geometric Properties	Loading
<i>S 275</i>	UB 457x152x74	$N = -3000 \text{ kN}$
	$b = 154.4 \text{ mm}$	$M_y = 500 \text{ kNm}$
	$h = 462.0 \text{ mm}$	
	$t_f = 17.0 \text{ mm}$	
	$t_w = 9.6 \text{ mm}$	
	$r = 10.2 \text{ mm}$	

Table 17.2: Results

Case	Part	Result	SOF.	Ref.
	Flange	$c/t$	3.66	3.66
	Web		42.46	42.46
Bending	Flange	Class	1	1
	Web		1	1
Compression	Flange	Class	1	1
	Web		4	4

## 17.4 Design Process<sup>1</sup>

Material:

Structural Steel S 275

$$f_y = 275 \text{ N/mm}^2 \text{ for maximum thickness } \leq 40 \text{ mm}$$

$$\epsilon = \sqrt{235/f_y} = 0.924$$

The role of cross-section classification is to identify the extent to which the resistance and rotation capacity of cross-sections is limited by its local buckling resistance.

### • Bending:

For the flange:  $c = b/2 - t_w/2 - r$

$$c / t = (154.4/2 - 9.6/2 - 10.2) / 17 = 3.66$$

$$c / t \leq 9 \epsilon \leq 8.32$$

→ Flange classification: Class 1

For the web:  $c = h - 2t_f - 2r$

$$c / t = (462 - 2 \cdot 17 - 2 \cdot 10.2) / 9.6 = 42.46$$

$$c / t \leq 72 \epsilon \leq 66.53$$

→ Web classification: Class 1

Overall classification for bending: **Class 1**

Class 1 cross-sections are those which can form a plastic hinge with the rotation capacity required from plastic analysis without reduction of the resistance.

### • Compression:

For the flange as above

→ Flange classification: Class 1

For the web as above :  $c / t = 42.46$

Class 3:  $c / t \leq 42 \epsilon \leq 38.8$

$$c / t = 42.46 > 38.8$$

→ Web classification: Class 4

Overall classification for bending: **Class 4**

Class 4 cross-sections are those in which local buckling will occur before the attainment of yield stress in one or more parts of the cross-section.

Tab. 3.1 : Nominal values of yield strength  $f_y$  and ultimate tensile strength  $f_u$  for hot rolled structural steel.

Tab. 5.2: Maximum width-to-thickness ratios for compression parts

Tab. 5.5.1(1): Classification of cross-section basis

Tab. 5.2 (sheet 2): Outstand flanges  
5.5.2 (3): The classification depends on the width to thickness ratio of the parts subject to compression

Tab. 5.2 (sheet 2): Outstand flanges - part subject to compression

Tab. 5.2 (sheet 1): Internal compression parts

Tab. 5.2 (sheet 1): Internal compression parts - part subject to bending

5.5.2 (1): Classification

Tab. 5.2 (sheet 1): Internal compression parts - part subject to compression

Tab. 5.5.2 (8): A part which fails to satisfy the limits of Class 3 should be taken as Class 4

Tab. 5.5.2 (6): A cross-section is classified according to the highest least favourable class

5.5.2 (1): Classification

<sup>1</sup>The sections mentioned in the margins refer to EN 1993-1-1:2005 [7] unless otherwise specified.

## 17.5 Conclusion

This example shows the classification of steel cross-sections for bending and compression. It has been shown that the results are reproduced with excellent accuracy.

## 17.6 Literature

- [7] *EN 1993-1-1: Eurocode 3: Design of concrete structures, Part 1-1: General rules and rules for buildings*. CEN. 2005.
  - [9] *Structural Eurocodes - Extracts from the structural Eurocodes for students of structural design*. BSI - British Standards Institution. 2007.
-





## 18 DCE-EN15: Buckling Resistance of Steel Members

### Overview

<b>Design Code Family(s):</b>	EN
<b>Design Code(s):</b>	EN 1993-1-1
<b>Module(s):</b>	BDK
<b>Input file(s):</b>	<a href="#">buckling_steel.dat</a>

### 18.1 Problem Description

The problem consists of a simply supported beam with a steel I-section subject to uniform end moments, as shown in Fig. 18.1. The cross-section is checked against buckling.

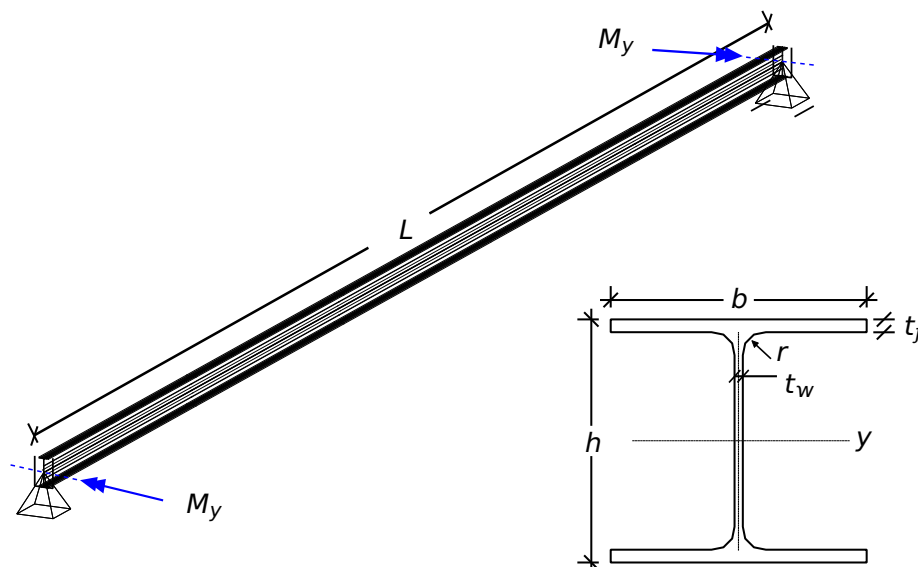

Figure 18.1: Problem Description

### 18.2 Reference Solution

This example is concerned with the buckling resistance of steel members. Lateral torsional buckling occurs in unrestrained, or inadequately restrained beams bent about the major axis and this causes the compression flange to buckle and deflect sideways, thus inducing twisting of the section. The content of this problem is covered by the following parts of EN 1993-1-1:2005 [7]:

- Structural steel (Section 3.2 )
- Classification of cross-sections (Section 5.5)
- Buckling resistance of members (Section 6.3)

### 18.3 Model and Results

The I-section, a UB 457x152x74, with properties as defined in Table 18.1, is to be checked for buckling, with respect to EN 1993-1-1:2005 [7]. The calculation steps [9] are presented below and the results are

given in Table 18.2.

Table 18.1: Model Properties

Material Properties	Geometric Properties	Loading
<i>S 275</i>	$L = 8 \text{ m}$	$M_y = 150 \text{ kNm}$
$E = 210000 \text{ N/mm}^2$	UB 457x152x74	
	$h = 462.0 \text{ mm}$	
	$b = 154.4 \text{ mm}$	
	$t_f = 17.0 \text{ mm}$	
	$t_w = 9.6 \text{ mm}$	
	$r = 10.2 \text{ mm}$	
	$A = 94.48 \text{ cm}^2$	
	$I_z = 1046.5 \text{ cm}^4$	
	$I_T = 66.23 \text{ cm}^4$	
	$I_w = 516297.12 \text{ cm}^6$	

Table 18.2: Results

	SOF.	Ref.
$M_{cr} [\text{kNm}]$	154.17	154.26
$\bar{\lambda}_{LT}$	1.703	1.703
$\Phi_{LT}$	1.907	1.907
$\chi_{LT}$	0.321	0.321
$M_{Ed}/M_{b,Rd} \text{ (BDK)}$	1.045	1.045

## 18.4 Design Process<sup>1</sup>

Material:

Structural Steel S 275

$$f_y = 275 \text{ N/mm}^2 \text{ for maximum thickness } \leq 40 \text{ mm}$$

$$\epsilon = \sqrt{235/f_y} = 0.924$$

Design Load:

$$M_{Ed} = 150 \text{ kNm}$$

The cross-section is classified as **Class 1**, as demonstrated in Benchmark DCE-EN14.

$$M_{c,Rd} = M_{pl,Rd,y} = \frac{W_{pl,y} \cdot f_y}{\gamma_{M0}} = 447.31 \text{ kNm}$$

$$M_{cr} = \frac{\pi \sqrt{EI_z GI_T}}{L} \sqrt{\left(1 + \frac{\pi^2 EI_w}{GI_T L^2}\right)}$$

$$M_{cr} = \frac{3.14 \cdot \sqrt{2197.74 \cdot 53.496}}{8} \sqrt{\left(1 + \frac{3.14^2 \cdot 108.42}{53.496 \cdot 8^2}\right)}$$

$$M_{cr} = 154.26 \text{ kNm}$$

$$\bar{\lambda}_{LT} = \sqrt{\frac{W_y f_y}{M_{cr}}} = \sqrt{\frac{447.31}{154.26}} = 1.703$$

$$\Phi_{LT} = 0.5 \left[1 + \alpha_{LT} \left(\bar{\lambda}_{LT} - \bar{\lambda}_{LT,0} + \beta \bar{\lambda}_{LT}^2\right)\right]$$

$$h/b = 462/154.4 = 2.99 > 2$$

for rolled I-sections and  $h/b > 2 \rightarrow$  buckling curve c

for buckling curve c  $\rightarrow \alpha_{LT} = 0.49$

$$\Phi_{LT} = 0.5 \left[1 + 0.49 \left(1.703 - 0.4 + 0.75 \cdot 1.703^2\right)\right] = 1.907$$

$$\chi_{LT} = \frac{1}{\Phi_{LT} + \sqrt{\Phi_{LT}^2 - \beta \bar{\lambda}_{LT}^2}} = 0.321$$

$$\text{but } \chi_{LT} = 0.321 \leq 1.0 \text{ and } \chi_{LT} = 0.321 \leq \frac{1}{\bar{\lambda}_{LT}^2} = 0.345$$

$$M_{b,Rd} = \chi_{LT} W_y \frac{f_y}{\gamma_{M1}} = 143.587 \text{ kNm}$$

$$\frac{M_{Ed}}{M_{b,Rd}} = 1.045 \rightarrow \text{Beam fails in LTB}$$

Tab. 3.1 : Nominal values of yield strength  $f_y$  and ultimate tensile strength  $f_u$  for hot rolled structural steel.

Tab. 5.2: Maximum width-to-thickness ratios for compression parts

Tab. 5.5: Classification of cross-section

6.2.5 (2):Eq. 6.13: Bending resistance  $M_{c,Rd}$  for Class 1 cross-section

6.1 (1):  $\gamma_{M0} = 1.00$

6.3.2.2 (2):  $M_{cr}$ , the elastic critical moment for ltb is based on gross cross sectional properties

Various empirical or approximate formulae exist for the determination of  $M_{cr}$

6.3.2.2 (1):  $\bar{\lambda}_{LT}$  non dimensional slenderness for lateral torsional buckling

6.3.2.3 (1):  $\Phi_{LT}$  for rolled sections in bending. Recommended values:

$\bar{\lambda}_{LT,0} = 0.4$  (maximum value)

$\beta = 0.75$  (minimum value)

6.3.2.3 (1): Table 6.5: Recommendation for the selection of ltb curve for cross-sections using Eq. 6.57

6.3.2.2 (2): Table 6.5: Recommendation values for imperfection factors  $\alpha_{LT}$  for ltb curves

6.3.2.3 (1): Eq. 6.57:  $\chi_{LT}$  reduction factor for ltb

6.3.2.1 (3): Eq. 6.55:  $M_{b,Rd}$  The design buckling resistance moment of laterally unrestrained beam

For Class 1 section  $W_y = W_{pl,y}$

6.1 (1):  $\gamma_{M1} = 1.00$  recommended value

<sup>1</sup>The sections mentioned in the margins refer to EN 1993-1-1:2005 [7] unless otherwise specified.

## 18.5 Conclusion

This example shows the check for lateral torsional buckling of steel members. It has been shown that the results are reproduced with excellent accuracy.

## 18.6 Literature

- [7] *EN 1993-1-1: Eurocode 3: Design of concrete structures, Part 1-1: General rules and rules for buildings*. CEN. 2005.
  - [9] *Structural Eurocodes - Extracts from the structural Eurocodes for students of structural design*. BSI - British Standards Institution. 2007.
-

## 19 DCE-EN17: Stress Calculation at a Rectangular Prestressed Concrete CS

### Overview

<b>Design Code Family(s):</b>	DIN
<b>Design Code(s):</b>	DIN EN 1992-1-1
<b>Module(s):</b>	AQB, TENDON
<b>Input file(s):</b>	<a href="#">stress_prestress.dat</a>

### 19.1 Problem Description

The problem consists of a rectangular cross-section of prestressed concrete, as shown in Fig. 19.1. The stresses developed at the section due to prestress and bending are verified.

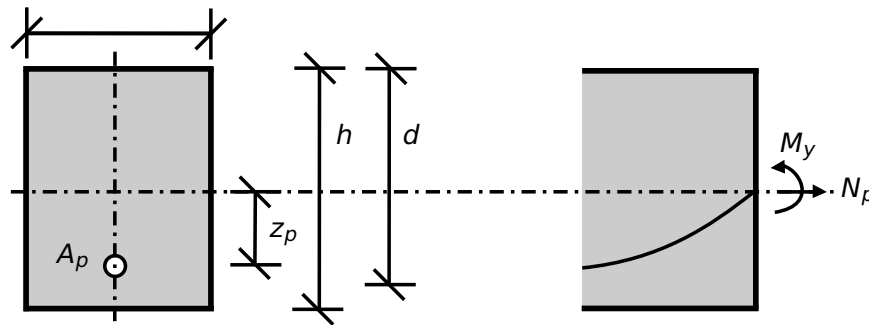

Figure 19.1: Problem Description

### 19.2 Reference Solution

This example is concerned with the design of prestressed concrete cs, subject to bending and prestress force. The content of this problem is covered by the following parts of DIN EN 1992-1-1:2004 [1]:

- Stress-strain curves for concrete and prestressing steel (Section 3.1.7, 3.3.6)
- Verification by the partial factor method - Design values (Section 2.4.2)
- Prestressing force (Section 5.10.2, 5.10.3)

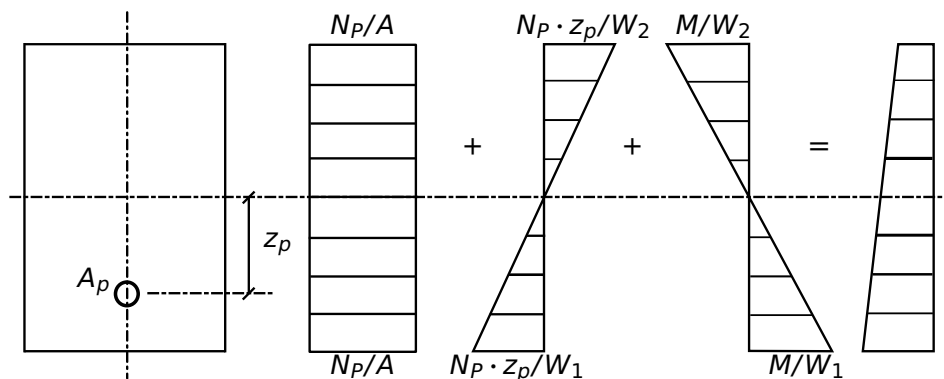

Figure 19.2: Stress Distribution in Prestress Concrete Cross-section

In rectangular cs, which are prestressed and loaded, stress conditions are developed, as shown in Fig. 19.2, where the different contributions of the loadings can be seen. The design stress-strain diagrams for prestressing steel is presented in Fig. 19.3, as defined in DIN EN 1992-1-1:2004 [1] (Section 3.3.6).

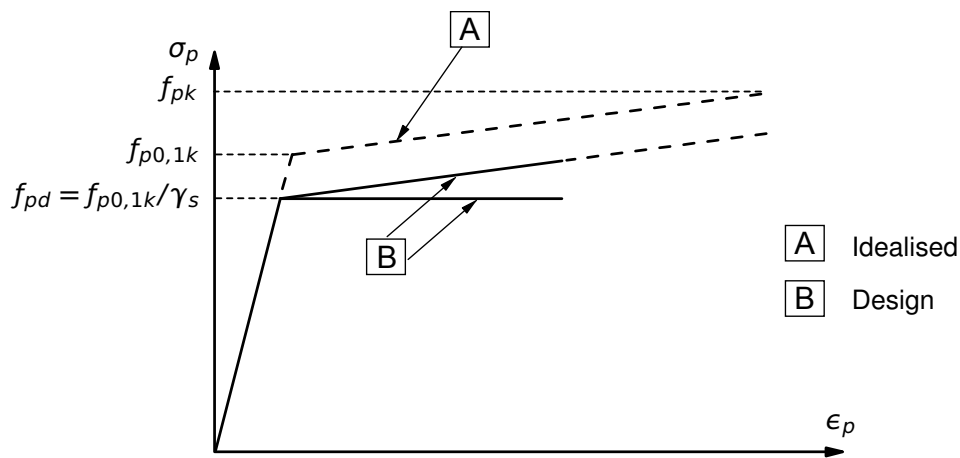

Figure 19.3: Idealised and Design Stress-Strain Diagram for Prestressing Steel

### 19.3 Model and Results

The simply supported beam of Fig. 19.4, consists of a rectangular cross-section with properties as defined in Table 19.1 and is prestressed and loaded with its own weight. A verification of the stresses is performed in the middle of the span with respect to DIN EN 1992-1-1:2004 (German National Annex) [1], [2]. The geometry of the tendon can be visualised in Fig. 19.5. The calculation steps [4] are presented below and the results are given in Table 19.2.

Table 19.1: Model Properties

Material Properties	Geometric Properties	Loading (at $x = 10\text{ m}$ )
C 35/45	$h = 100.0\text{ cm}$	$M_g = 1250\text{ kNm}$
Y 1770	$b = 100.0\text{ cm}$	$N_p = -3651.1\text{ kN}$
	$d = 95.0\text{ cm}$	
	$L = 20.0\text{ m}$	
	$A_p = 28.5\text{ cm}^2$	

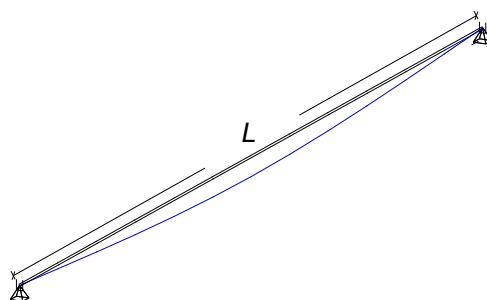

Figure 19.4: Simply Supported Beam

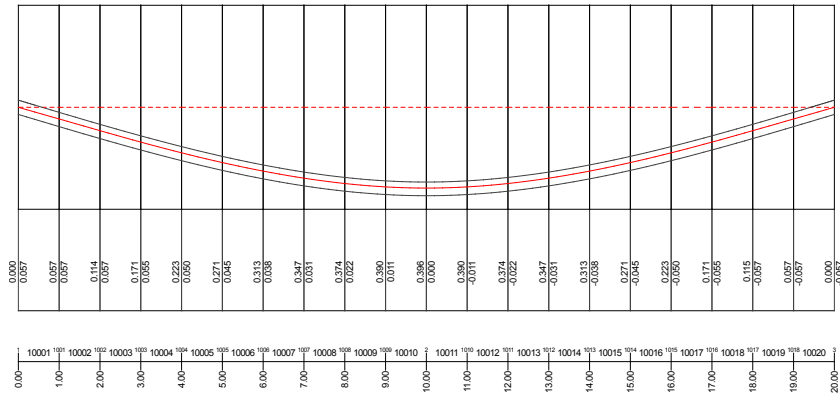

Figure 19.5: Tendon Geometry

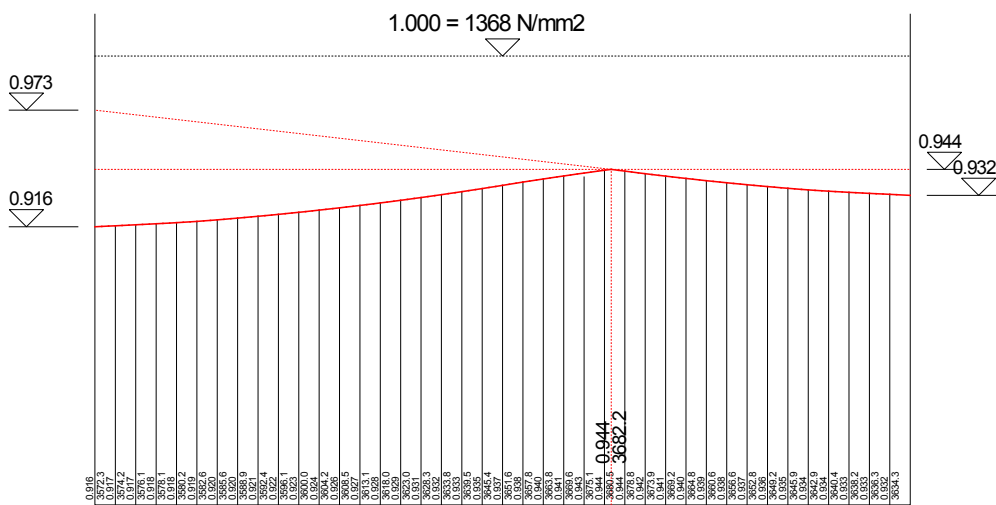

Figure 19.6: Prestress Forces and Stresses

Table 19.2: Results

Case	CS	Result	SOF.	Ref.
I	0	$\sigma_{c,b}$ [MPa]	-12.47	-12.47
		$M_y$ [kNm]	-1435.91	-1435.91
II	0	$M_y$ [kNm]	-4.82	-4.82
		$M_y$ [kNm]	-185.91	-185.91
III	1	$M_y$ [kNm]	-11.76	-11.76
		$M_y$ [kNm]	-1406.11	-1406.11
IV	1	$M_y$ [kNm]	-4.51	-4.51
		$M_y$ [kNm]	-156.11	-156.11

## 19.4 Design Process<sup>1</sup>

Design with respect to DIN EN 1992-1-1:2004 (NA) [1] [2]:<sup>2</sup>

Material:

3.1: Concrete

Concrete: C 35/45

3.1.2: Tab. 3.1:  $E_{cm}$  for C 35/45

$$E_{cm} = 34000 \text{ N/mm}^2$$

3.3: Prestressing Steel

Prestressing Steel: Y 1770

3.3.6 (3):  $E_p$  for wires

$$E_p = 195000 \text{ N/mm}^2$$

3.3.2, 3.3.3:  $f_{pk}$  Characteristic tensile strength of prestressing steel

$$f_{pk} = 1770 \text{ N/mm}^2$$

3.3.2, 3.3.3:  $f_{p0,1k}$  0.1% proof-stress of prestressing steel, yield strength

$$f_{p0,1k} = 1520 \text{ N/mm}^2$$

Prestressing system: *BBV L19 150 mm<sup>2</sup>*

19 wires with area of  $150 \text{ mm}^2$  each, giving a total of  $A_p = 28.5 \text{ cm}^2$

Cross-section:

$$A_c = 1.0 \cdot 1.0 = 1 \text{ m}^2$$

Diameter of duct  $\phi_{duct} = 97 \text{ mm}$

$$\text{Ratio } \alpha_{E,p} = E_p / E_{cm} = 195000 / 34000 = 5.74$$

$$A_{c,netto} = A_c - \pi \cdot (\phi_{duct}/2)^2 = 0.9926 \text{ m}^2$$

$$A_{ideal} = A_c + A_p \cdot \alpha_{E,p} = 1.013 \text{ m}^2$$

5.10.2.1 (1)P: Prestressing force during tensioning - Maximum stressing force

The force applied to a tendon, i.e. the force at the active end during tensioning, should not exceed the following value

5.10.2.1 (1)P: Eq. 5.41:  $P_{max}$  maximum stressing force

$$P_{max} = A_p \cdot \sigma_{p,max}$$

(NDP) 5.10.2.1 (1)P:  $\sigma_{p,max}$  maximum stress applied to the tendon

$$\text{where } \sigma_{p,max} = \min \{ 0.80f_{pk}; 0.90f_{p0,1k} \}$$

$$P_{max} = A_p \cdot 0.80 \cdot f_{pk} = 28.5 \cdot 10^{-4} \cdot 0.80 \cdot 1770 = 4035.6 \text{ kN}$$

$$P_{max} = A_p \cdot 0.90 \cdot f_{p0,1k} = 28.5 \cdot 10^{-4} \cdot 0.90 \cdot 1520 = 3898.8 \text{ kN}$$

$$\rightarrow P_{max} = 3898.8 \text{ kN and } \sigma_{p,max} = 1368 \text{ N/mm}^2$$

5.10.3 (2): Prestress force

The value of the initial prestress force at time  $t = t_0$  applied to the concrete immediately after tensioning and anchoring should not exceed the following value

5.10.3 (2): Eq. 5.43:  $P_{m0}$  initial prestress force at time  $t = t_0$

$$P_{m0}(x) = A_p \cdot \sigma_{p,m0}(x)$$

<sup>1</sup>The tools used in the design process are based on steel stress-strain diagrams, as defined in [1] 3.3.6: Fig. 3.10, which can be seen in Fig 19.3.

<sup>2</sup>The sections mentioned in the margins refer to DIN EN 1992-1-1:2004 (German National Annex) [1], [2], unless otherwise specified.



where  $\sigma_{p,m0}(x) = \min \{0.75f_{pk}; 0.85f_{p0,1k}\}$

$$P_{m0} = A_p \cdot 0.75 \cdot f_{pk} = 28.5 \cdot 10^{-4} \cdot 0.75 \cdot 1770 = 3783.4 \text{ kN}$$

$$P_{m0} = A_p \cdot 0.85 \cdot f_{p0,1k} = 28.5 \cdot 10^{-4} \cdot 0.85 \cdot 1520 = 3682.2 \text{ kN}$$

$$\rightarrow P_{m0} = 3682.2 \text{ kN and } \sigma_{p,m0} = 1292 \text{ N/mm}^2$$

(NDP) 5.10.3 (2):  $\sigma_{p,m0}(x)$  stress in the tendon immediately after tensioning or transfer

Further calculations for the distribution of prestress forces and stresses along the beam are not in the scope of this Benchmark and will not be described here. The complete diagram can be seen in Fig. 19.5, after the consideration of losses at anchorage and due to friction, as calculated by SOFiSTiK. There the values of  $\sigma_{p,max} = 1368 \text{ N/mm}^2$  and  $P_{m0} = 3682.2 \text{ kN}$  can be visualised.

Load Actions:

Self weight per length:  $\gamma = 25 \text{ kN/m}$

$$\rightarrow g_1 = \gamma \cdot A = 25 \cdot 1 = 25 \text{ kNm}$$

Safety factors at ultimate limit state

Actions (unfavourable)	Safety factor at final state
• permanent	$\gamma_G = 1.35$
• prestress	$\gamma_P = 1.00$

DIN EN 1990/NA [10]: (NDP) A.1.3.1 (4): Tab. NA.A.1.2 (B): Partial factors for actions  
(NDP) 2.4.2.2 (1): Partial factors for prestress

Combination coefficients at serviceability limit state

$g_1 = 25 \text{ kNm}$ : for rare, frequent and quasi-permanent combination (for stresses)

At  $x = 10.0 \text{ m}$  middle of the span:

$$M_g = g_1 \cdot L^2 / 8 = 1250 \text{ kNm}$$

$$N_p = P_{m0}(x = 10.0 \text{ m}) = -3653.0 \text{ kN (from SOFiSTiK)}$$

**Calculation of stresses  $\sigma_{c,b}$  at  $x = 10.0 \text{ m}$  middle of the span:**

Position of the tendon:  $z = 0,3901 \text{ m}$

- Case I: Prestress at construction stage section 0 (P cs0)

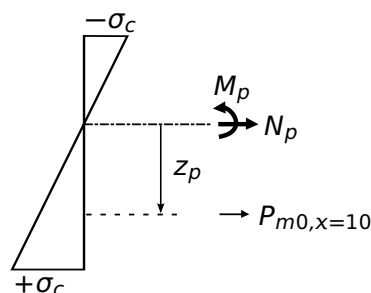

$$N_p = -3653.0 \text{ kN}$$

The concrete stresses may be determined for each construction stage under the total quasi-permanent combination  $\sigma_c \{G + P_{m0} + \psi_2 \cdot Q\}$   
In this Benchmark no variable load  $Q$  is examined

$z_s$  the new position of the center of the cross-section for cs0  
 $z_p = z + z_s$

$M_p$  bending moment caused by prestressing

$W_{1,cs0}$  cross-section moduli for construction stage 0 at the bottom left and right point

$\sigma_{c,b}$  stress at the concrete at the bottom of the cross section

$$M_{p1} = N_p \cdot z = -3653.0 \cdot 0.3901 = -1425.04 \text{ kNm}$$

$$M_{p2} = N_p \cdot z_s = -3653.0 \cdot 0.002978 = -10.879 \text{ kNm}$$

$$M_p = -1425.04 - 10.879 = -1435.91 \text{ kNm} = M_y$$

$$\sigma_{c,b} = \frac{N_p}{A_{c,netto}} + \frac{M_y}{W_{1,cs0}}$$

$$\sigma_{c,b} = \frac{-3653.0}{0.9926} + \frac{-1435.91}{0.1633} = -12.47 \text{ MPa}$$

- **Case II:** Prestress and self-weight at con. stage sect. 0 (P+G cs0)

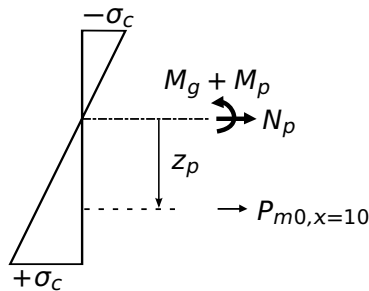

$$N_p = -3653.0 \text{ kN and } M_g = 1250 \text{ kNm}$$

$$\text{As computed above: } M_p = -1435.91 \text{ kNm}$$

$$M_y = 1250 - 1435.91 = -185.91 \text{ kNm}$$

$$\sigma_{c,b} = \frac{-3653.0}{0.9926} + \frac{-185.91}{0.1633} = -4.82 \text{ MPa}$$

- **Case III:** Prestress at con. stage sect. 1 (P cs1)

$$N_p = -3653.0 \text{ kN and } M_{p1} = -1425.04 \text{ kNm (as above)}$$

$$M_{p2} = N_p \cdot z_s = -3653.0 \cdot (-0.00518) = 18.92 \text{ kNm}$$

$$M_p = -1425.04 + 18.92 = -1406.11 \text{ kNm} = M_y$$

$$\sigma_{c,b} = \frac{N_p}{A_{ideal}} + \frac{M_y}{W_{1,cs1}}$$

$$\sigma_{c,b} = \frac{-3653.0}{1.013} + \frac{-1406.11}{0.172} = -11.76 \text{ MPa}$$

$W_{1,cs1}$  cross-section moduli for construction stage 1

- **Case IV:** Prestress and self-weight at con. stage sect. 1 (P+G cs1)

$$N_p = -3653.0 \text{ kN and } M_g = 1250 \text{ kNm}$$

$$\text{As computed above: } M_p = -1406.11 \text{ kNm}$$

$$M_y = 1250 - 1406.11 = -156.11 \text{ kNm}$$

$$\sigma_{c,b} = \frac{-3653.0}{1.013} + \frac{-156.11}{0.172} = -4.51 \text{ MPa}$$

## 19.5 Conclusion

This example shows the calculation of the stresses, developed in the concrete cross-section due to prestress and bending. It has been shown that the results are reproduced with excellent accuracy.

## 19.6 Literature

- [1] *DIN EN 1992-1-1/NA: Eurocode 2: Design of concrete structures, Part 1-1/NA: General rules and rules for buildings - German version EN 1992-1-1:2005 (D), Nationaler Anhang Deutschland - Stand Februar 2010.* CEN. 2010.
  - [2] F. Fingerloos, J. Hegger, and K. Zilch. *DIN EN 1992-1-1 Bemessung und Konstruktion von Stahlbeton- und Spannbetontragwerken - Teil 1-1: Allgemeine Bemessungsregeln und Regeln für den Hochbau.* BVPI, DBV, ISB, VBI. Ernst & Sohn, Beuth, 2012.
  - [4] *Beispiele zur Bemessung nach Eurocode 2 - Band 1: Hochbau.* Ernst & Sohn. Deutschen Beton- und Bautechnik-Verein E.V. 2011.
  - [10] *DIN EN 1990/NA: Eurocode: Basis of structural design, Nationaler Anhang Deutschland DIN EN 1990/NA:2010-12.* CEN. 2010.
-



## 20 DCE-EN18: Creep and Shrinkage Calculation of a Rectangular Prestressed Concrete CS

### Overview

<b>Design Code Family(s):</b>	DIN
<b>Design Code(s):</b>	DIN EN 1992-1-1
<b>Module(s):</b>	AQB, CSM
<b>Input file(s):</b>	<a href="#">creep_shrinkage.dat</a>

### 20.1 Problem Description

The problem consists of a simply supported beam with a rectangular cross-section of prestressed concrete, as shown in Fig. 20.1. The time dependent losses are calculated, considering the reduction of stress caused by the deformation of concrete due to creep and shrinkage, under the permanent loads.

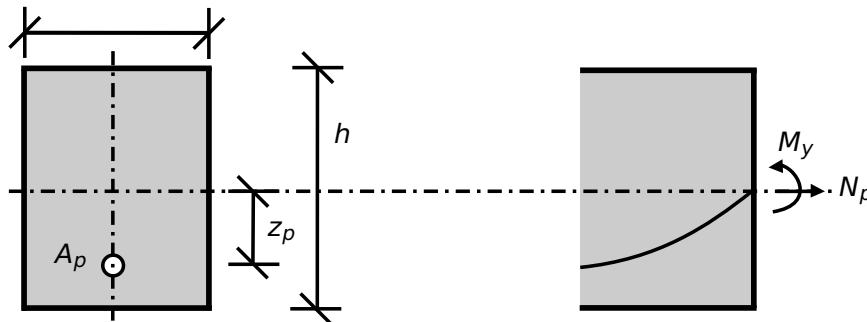

Figure 20.1: Problem Description

### 20.2 Reference Solution

This example is concerned with the calculation of creep and shrinkage on a prestressed concrete CS, subject to bending and prestress force. The content of this problem is covered by the following parts of DIN EN 1992-1-1:2004 [1]:

- Creep and Shrinkage (Section 3.1.4)
- Annex B: Creep and Shrinkage (Section B.1, B.2)
- Time dependent losses of prestress for pre- and post-tensioning (Section 5.10.6)

The time dependant losses may be calculated by considering the following two reductions of stress [1]:

- due to the reduction of strain, caused by the deformation of concrete due to creep and shrinkage, under the permanent loads
- the reduction of stress in the steel due to the relaxation under tension.

In this Benchmark the stress loss due to creep and shrinkage will be examined.

## 20.3 Model and Results

Benchmark 17 is here extended for the case of creep and shrinkage developing on a prestressed concrete simply supported beam. The analysed system can be seen in Fig. 20.2, with properties as defined in Table 20.1. Further information about the tendon geometry and prestressing can be found in Benchmark 17. The beam consists of a rectangular cs and is prestressed and loaded with its own weight. A calculation of the creep and shrinkage is performed in the middle of the span with respect to DIN EN 1992-1-1:2004 (German National Annex) [1], [2]. The calculation steps [4] are presented below and the results are given in Table 20.2 for the calculation with AQB. For CSM only the results of the creep coefficients and the final losses are given, since the calculation is performed in steps.

Table 20.1: Model Properties

Material Properties	Geometric Properties	Loading (at $x = 10\text{ m}$ )	Time
C 35/45	$h = 100.0\text{ cm}$	$M_g = 1250\text{ kNm}$	$t_0 = 28\text{ days}$
Y 1770	$b = 100.0\text{ cm}$	$N_p = -3653.0\text{ kN}$	$t_s = 0\text{ days}$
$RH = 80$	$L = 20.0\text{ m}$		$t_{eff} = 1000000\text{ days}$
	$A_p = 28.5\text{ cm}^2$		

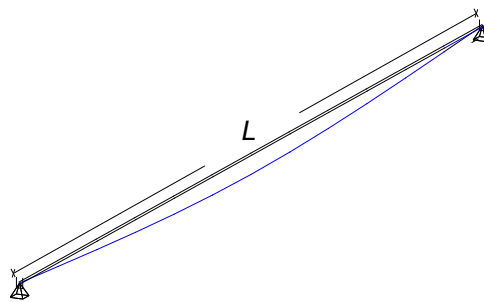

Figure 20.2: Simply Supported Beam

Table 20.2: Results

Result	AQB	CSM+AQB	Ref.
$\epsilon_{CS}$	$-18.85 \cdot 10^{-5}$	-	$-18.85 \cdot 10^{-5}$
$\epsilon$	$-31.58 \cdot 10^{-5}$	-	$-31.58 \cdot 10^{-5}$
$\phi_0$	1.463	1.463	1.463
$\phi(t, t_0)$	1.393	1.393	1.393
$\Delta\sigma_{p,c+s}$ [MPa]	-66.63	-67.30	-68.45
$\Delta P_{c+s}$ [kN]	189.9	191.8	195.11

## 20.4 Design Process<sup>1</sup>

### Design with respect to DIN EN 1992-1-1:2004 (NA) [1] [2]:<sup>2</sup>

Material:

Concrete: C 35/45

3.1: Concrete

$$E_{cm} = 34077 \text{ N/mm}^2$$

3.1.2: Tab. 3.1:  $E_{cm}$ ,  $f_{ck}$  and  $f_{cm}$  for C 35/45

$$f_{ck} = 35 \text{ N/mm}^2$$

$$f_{cm} = 43 \text{ N/mm}^2$$

Prestressing Steel: Y 1770

3.3: Prestressing Steel

$$E_p = 195000 \text{ N/mm}^2$$

3.3.6 (3):  $E_p$  for wires

$$f_{pk} = 1770 \text{ N/mm}^2$$

3.3.2, 3.3.3:  $f_{pk}$  Characteristic tensile strength of prestressing steel

Prestressing system: BBV L19 150 mm<sup>2</sup>

19 wires with area of 150 mm<sup>2</sup> each, giving a total of  $A_p = 28.5 \text{ cm}^2$

Cross-section:

$$A_c = 1.0 \cdot 1.0 = 1 \text{ m}^2$$

Diameter of duct  $\phi_{duct} = 97 \text{ mm}$

$$\text{Ratio } \alpha_{E,p} = E_p / E_{cm} = 195000 / 34077 = 5.7223$$

$$A_{c,netto} = A_c - \pi \cdot (\phi_{duct}/2)^2 = 0.9926 \text{ m}^2$$

$$A_{ideal} = A_c + A_p \cdot \alpha_{E,p} = 1.013 \text{ m}^2$$

Load Actions:

Self weight per length:  $\gamma = 25 \text{ kN/m}$

At  $x = 10.0 \text{ m}$  middle of the span:

$$M_g = g_1 \cdot L^2 / 8 = 1250 \text{ kNm}$$

$$N_p = P_{m0}(x = 10.0 \text{ m}) = -3653.0 \text{ kN (from SOFiSTiK)}$$

**Calculation of stresses** at  $x = 10.0 \text{ m}$  midspan:

Position of the tendon:  $z_{cp} = 0,3901 \text{ m}$

Prestress and self-weight at con. stage sect. 0 (P+G cs0)

<sup>1</sup>The tools used in the design process are based on steel stress-strain diagrams, as defined in [1] 3.3.6: Fig. 3.10

<sup>2</sup>The sections mentioned in the margins refer to DIN EN 1992-1-1:2004 (German National Annex) [1], [2], unless otherwise specified.

$$N_p = -3653.0 \text{ kN and } M_g = 1250 \text{ kNm}$$

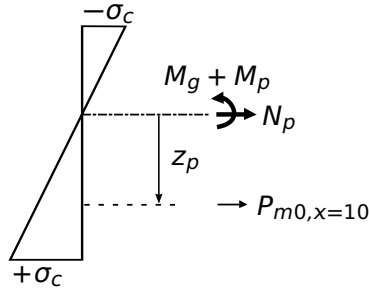

$z_s$  the new position of the center of the cross-section for cs0

$$z_p = z_{cp} + z_s$$

$M_p$  bending moment caused by pre-stressing

$$M_{p1} = N_p \cdot z_{cp} = -3653.0 \cdot 0.3901 = -1425.04 \text{ kNm}$$

$$M_{p2} = N_p \cdot z_s = -3653.0 \cdot 0.002978 = -10.879 \text{ kNm}$$

$$M_p = -1425.04 - 10.879 = -1435.91 \text{ kNm}$$

$$M_y = 1250 - 1435.91 = -185.91 \text{ kNm}$$

$\sigma_{c,QP}$  stress in concrete

$$\sigma_{c,QP} = \frac{-3653.0}{0.9926} + \frac{-185.91}{0.1633} = -4.82 \text{ MPa}$$

### Calculation of creep and shrinkage at $x = 10.0 \text{ m}$ midspan:

$t_0$  minimum age of concrete for loading

$t_s$  age of concrete at start of drying shrinkage

$t$  age of concrete at the moment considered

$$t_0 = 28 \text{ days}$$

$$t_s = 0 \text{ days}$$

$$t = t_{eff} + t_0 = 1000000 + 28 = 1000028 \text{ days}$$

3.1.4 (6): Eq. 3.8:  $\epsilon_{cs}$  total shrinkage strain

3.1.4 (6): Eq. 3.9:  $\epsilon_{cd}$  drying shrinkage strain

$$\epsilon_{cs} = \epsilon_{cd} + \epsilon_{ca}$$

$$\epsilon_{cd}(t) = \beta_{ds}(t, t_s) \cdot k_h \cdot \epsilon_{cd,0}$$

The development of the drying shrinkage strain in time is strongly depends on  $\beta_{ds}(t, t_s)$  factor. SOFiSTiK accounts not only for the age at start of drying  $t_s$  but also for the influence of the age of the prestressing  $t_0$ . Therefore, the calculation of factor  $\beta_{ds}$  reads:

3.1.4 (6): Eq. 3.10:  $\beta_{ds}$

3.1.4 (6):  $h_0$  the notional size (mm) of the cs  $h_0 = 2A_c/u = 500 \text{ mm}$

$$\beta_{ds} = \beta_{ds}(t, t_s) - \beta_{ds}(t_0, t_s)$$

$$\beta_{ds} = \frac{(t - t_s)}{(t - t_s) + 0.04 \cdot \sqrt{h_0^3}} - \frac{(t_0 - t_s)}{(t_0 - t_s) + 0.04 \cdot \sqrt{h_0^3}}$$

$$\beta_{ds} = \frac{(1000028 - 0)}{(1000028 - 0) + 0.04 \cdot \sqrt{500^3}} - \frac{(28 - 0)}{(28 - 0) + 0.04 \cdot \sqrt{500^3}}$$

$$\beta_{ds} = 0.99955 - 0.05892 = 0.94063$$

3.1.4 (6): Tab. 3.3:  $k_h$  coefficient depending on  $h_0$

Annex B.2 (1): Eq. B.11:  $\epsilon_{cd,0}$  basic drying shrinkage strain

Annex B.2 (1): Eq. B.12:  $\beta_{RH}$   
 $RH$  the ambient relative humidity (%)

$$k_h = 0.70 \text{ for } h_0 \geq 500 \text{ mm}$$

$$\epsilon_{cd,0} = 0.85 \left[ (220 + 110 \cdot \alpha_{ds1}) \cdot \exp\left(-\alpha_{ds2} \cdot \frac{f_{cm}}{f_{cm0}}\right) \right] \cdot 10^{-6} \cdot \beta_{RH}$$

$$\beta_{RH} = 1.55 \left[ 1 - \left( \frac{RH}{RH_0} \right)^3 \right] = 1.55 \left[ 1 - \left( \frac{80}{100} \right)^3 \right] = 0.7564$$



$$\epsilon_{cd,0} = 0.85 \left[ (220 + 110 \cdot 4) \cdot \exp\left(-0.12 \cdot \frac{43}{10}\right) \right] \cdot 10^{-6} \cdot 0.7564$$

Annex B.2 (1):  $\alpha_{ds1}, \alpha_{ds2}$  coefficients depending on type of cement.  
For class N  $\alpha_{ds1} = 4, \alpha_{ds2} = 0.12$

$$\epsilon_{cd,0} = 2.533 \cdot 10^{-4}$$

$$\epsilon_{cd} = 0.94063 \cdot 0.70 \cdot 2.533 \cdot 10^{-4} = 0.0001668$$

$$\epsilon_{cd} = 1.668 \cdot 10^{-4} = 0.1668 \text{ ‰}$$

$$\epsilon_{ca}(t) = \beta_{as}(t) \cdot \epsilon_{ca}(\infty)$$

3.1.4 (6): Eq. 3.11:  $\epsilon_{ca}$  autogenous shrinkage strain

$$\epsilon_{ca}(\infty) = 2.5 (f_{ck} - 10) \cdot 10^{-6} = 2.5 (35 - 10) \cdot 10^{-6}$$

3.1.4 (6): Eq. 3.12:  $\epsilon_{ca}(\infty)$

$$\epsilon_{ca}(\infty) = 6.25 \cdot 10^{-5} = 0.0625 \text{ ‰}$$

Proportionally to  $\beta_{ds}(t, ts)$ , SOFiSTiK calculates factor  $\beta_{as}$  as follows:

$$\beta_{as} = \beta_{as}(t) - \beta_{as}(t_0)$$

3.1.4 (6): Eq. 3.13:  $\beta_{as}$

$$\beta_{as} = 1 - e^{-0.2 \cdot \sqrt{t}} - \left( 1 - e^{-0.2 \cdot \sqrt{t_0}} \right) = e^{-0.2 \cdot \sqrt{t_0}} - e^{-0.2 \cdot \sqrt{t}}$$

$$\beta_{as} = 0.347$$

$$\epsilon = \epsilon_{cd,0} + \epsilon_{ca}(\infty) = 2.533 \cdot 10^{-4} + 6.25 \cdot 10^{-5}$$

$$\epsilon = -31.58 \cdot 10^{-5}$$

$\epsilon$  absolute shrinkage strain  
negative sign to declare losses

$$\epsilon_{ca} = 0.347 \cdot 6.25 \cdot 10^{-5} = 2.169 \cdot 10^{-5} = 0.02169 \text{ ‰}$$

$$\epsilon_{cs} = 1.668 \cdot 10^{-4} + 2.169 \cdot 10^{-5} = -18.85 \cdot 10^{-5}$$

negative sign to declare losses

$$\phi(t, t_0) = \phi_0 \cdot \beta_c(t, t_0)$$

Annex B.1 (1): Eq. B.1:  $\phi(t, t_0)$  creep coefficient

$$\phi_0 = \phi_{RH} \cdot \beta(f_{cm}) \cdot \beta(t_0)$$

Annex B.1 (1): Eq. B.2:  $\phi_0$  notional creep coefficient

$$\phi_{RH} = \left[ 1 + \frac{1 - RH/100}{0.1 \cdot \sqrt[3]{h_0}} \cdot \alpha_1 \right] \cdot \alpha_2$$

Annex B.1 (1): Eq. B.3:  $\phi_{RH}$  factor for effect of relative humidity on creep

$$\beta(f_{cm}) = \frac{16.8}{\sqrt{f_{cm}}} = 16.8 / \sqrt{43} = 2.562$$

Annex B.1 (1): Eq. B.4:  $\beta(f_{cm})$  factor for effect of concrete strength on creep

$$\alpha_1 = \left[ \frac{35}{f_{cm}} \right]^{0.7} \leq 1 = 0.8658$$

Annex B.1 (1): Eq. B.8c:  $\alpha_1, \alpha_2, \alpha_3$  coefficients to consider influence of concrete strength

$$\alpha_2 = \left[ \frac{35}{f_{cm}} \right]^{0.2} \leq 1 = 0.9597$$

$$\alpha_3 = \left[ \frac{35}{f_{cm}} \right]^{0.5} \leq 1 = 0.9022$$

$$\phi_{RH} = \left[ 1 + \frac{1 - 80/100}{0.1 \cdot \sqrt[3]{500}} \cdot 0.8658 \right] \cdot 0.9597 = 1.1691$$

$$\beta(t_0) = \frac{1}{(0.1 + t_0^{0.20})}$$

Annex B.1 (1): Eq. B.5:  $\beta(t_0)$  factor for effect of concrete age at loading on creep

Annex B.1 (2): Eq. B.9:  $t_{0,T}$  temperature adjusted age of concrete at loading adjusted according to expression B.10

Annex B.1 (3): Eq. B.10:  $t_T$  temperature adjusted concrete age which replaces  $t$  in the corresponding equations

Annex B.1 (2): Eq. B.9:  $\alpha$  a power which depends on type of cement  
For class N  $\alpha = 0$

Annex B.1 (1): Eq. B.7:  $\beta_c(t, t_0)$  coefficient to describe the development of creep with time after loading

Annex B.1 (1): Eq. B.8:  $\beta_H$  coefficient depending on relative humidity and notional member size

Annex B.1 (3): The values of  $\phi(t, t_0)$  given above should be associated with the tangent modulus  $E_c$

3.1.4 (2): The values of the creep coefficient,  $\phi(t, t_0)$  is related to  $E_c$ , the tangent modulus, which may be taken as  $1.05 \cdot E_{cm}$

5.10.6 (2): Eq. 5.46:  $\Delta P_{c+s+r}$  time dependent losses of prestress

$\Delta\sigma_{p,c+s}$  variation of stress in tendons due to creep and shrinkage at location  $x$ , at time  $t$

$$t_0 = t_{0,T} \cdot \left( \frac{9}{2 + t_{0,T}^{1.2}} + 1 \right)^\alpha \geq 0.5$$

$$t_T = \sum_{i=1}^n e^{-(4000/[273+T(\Delta t_i)]-13.65)} \cdot \Delta t_i$$

$$t_{0,T} = 28 \cdot e^{-(4000/[273+20]-13.65)} = 28 \cdot 1.0 = 28.0$$

$$\Rightarrow t_0 = 28.0 \cdot \left( \frac{9}{2 + 28.0^{1.2}} + 1 \right)^0 = 28.0$$

$$\beta(t_0) = \frac{1}{(0.1 + 28.0^{0.20})} = 0.48844$$

$$\beta_c(t, t_0) = \left[ \frac{(t - t_0)}{(\beta_H + t - t_0)} \right]^{0.3}$$

$$\beta_H = 1.5 \cdot [1 + (0.012 \cdot RH)^{18}] \cdot h_0 + 250 \cdot \alpha_3 \leq 1500 \cdot \alpha_3$$

$$\beta_H = 1.5 \cdot [1 + (0.012 \cdot 80)^{18}] \cdot 500 + 250 \cdot 0.9022$$

$$\beta_H = 1335.25 \leq 1500 \cdot 0.9022 = 1353.30$$

$$\Rightarrow \beta_c(t, t_0) = 0.9996$$

$$\phi_0 = 1.1691 \cdot 2.562 \cdot 0.48844 = 1.463$$

$$\phi(t, t_0) = 1.463 \cdot 0.9996/1.05 = 1.393$$

According to EN, the creep value is related to the tangent Young's modulus  $E_c$ , where  $E_c$  being defined as  $1.05 \cdot E_{cm}$ . To account for this, SOFiSTiK adopts this scaling for the computed creep coefficient (in SOFiSTiK, all computations are consistently based on  $E_{cm}$ ).

$$\Delta P_{c+s+r} = A_p \cdot \Delta\sigma_{p,c+s+r} = A_p \frac{\epsilon_{cs} \cdot E_p + 0.8 \Delta\sigma_{pr} + \frac{E_p}{E_{cm}} \phi(t, t_0) \cdot \sigma_{c,QP}}{1 + \frac{E_p}{E_{cm}} \frac{A_p}{A_c} \left( 1 + \frac{A_c}{I_c} z_{cp}^2 \right) [1 + 0.8 \phi(t, t_0)]}$$

In this example only the losses due to creep and shrinkage are taken into account, the reduction of stress due to relaxation ( $\Delta\sigma_{pr}$ ) is ignored.

$$\Delta\sigma_{p,c+s} = \frac{-0.1885 \cdot 10^{-3} \cdot 195000 + 5.7223 \cdot 1.393 \cdot (-4.82)}{1 + 5.7223 \frac{28.5 \cdot 10^{-4}}{0.9926} \left( 1 + \frac{0.9926}{0.08214} 0.3901^2 \right) [1 + 0.8 \cdot 1.393]}$$

$$\Delta\sigma_{p,c+s} = -68.46 \text{ MPa}$$

$$\Delta P_{c+s} = A_p \cdot \Delta\sigma_{p,c+s} = 28.5 \cdot 10^{-4} \cdot 68.46 \cdot 10^3 = 195.11 \text{ kN}$$

## 20.5 Conclusion

This example shows the calculation of the time dependent losses due to creep and shrinkage. It has been shown that the results are in very good agreement with the reference solution.

## 20.6 Literature

- [1] *DIN EN 1992-1-1/NA: Eurocode 2: Design of concrete structures, Part 1-1/NA: General rules and rules for buildings - German version EN 1992-1-1:2005 (D), Nationaler Anhang Deutschland - Stand Februar 2010.* CEN. 2010.
  - [2] F. Fingerloos, J. Hegger, and K. Zilch. *DIN EN 1992-1-1 Bemessung und Konstruktion von Stahlbeton- und Spannbetontragwerken - Teil 1-1: Allgemeine Bemessungsregeln und Regeln für den Hochbau.* BVPI, DBV, ISB, VBI. Ernst & Sohn, Beuth, 2012.
  - [4] *Beispiele zur Bemessung nach Eurocode 2 - Band 1: Hochbau.* Ernst & Sohn. Deutschen Beton- und Bautechnik-Verein E.V. 2011.
-



## 21 DCE-EN19: Fatigue of a Rectangular Reinforced Concrete CS

### Overview

<b>Design Code Family(s):</b>	DIN
<b>Design Code(s):</b>	DIN EN 1992-1-1
<b>Module(s):</b>	AQB
<b>Input file(s):</b>	<a href="#">fatigue.dat</a>

### 21.1 Problem Description

The problem consists of a simply supported box girder beam of reinforced concrete, as shown in Fig. 21.1. The structure's resistance to fatigue shall be verified.

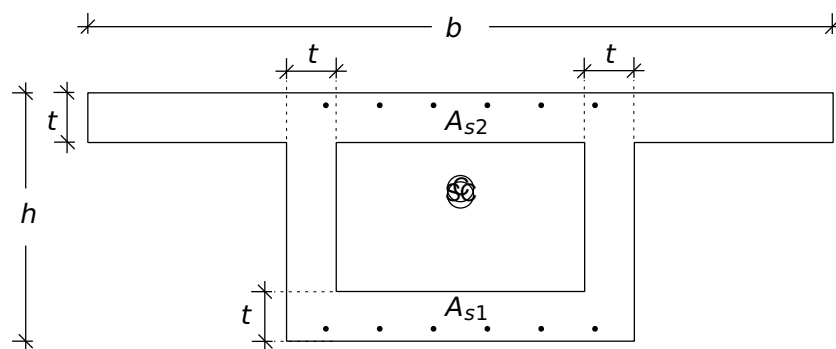

Figure 21.1: Problem Description

### 21.2 Reference Solution

This example is concerned with the verification to fatigue. The content of this problem is covered by the following parts of DIN EN 1992-1-1/NA [11] [2]:

- Verification conditions (Section 6.8.1)
- Internal forces and stresses for fatigue verification (Section 6.8.2)
- Combination of actions (Section 6.8.3)
- Verification procedure for reinforcing and prestressing steel (Section 6.8.4)
- Verification using damage equivalent stress range (Section 6.8.5)
- Verification of concrete under compression or shear (Section 6.8.7)

### 21.3 Model and Results

The properties of the simply supported beam of reinforced concrete with a box cross-section are defined in Table 21.1. The beam is loaded with three combinations of load cases with calculative forces and moments, as presented in Table 21.1. A verification of its resistance to fatigue is performed at  $x = 5 \text{ m}$  with respect to DIN EN 1992-1-1/NA [11] [2]. The results are given in Table 21.2

Table 21.1: Model Properties

Material	Geometry	Loading (at $x = 5\text{ m}$ )
C 35/45	$h = 200.0\text{ cm}$	LC 911:
S 500	$b = 600.0\text{ cm}$	$V_z = 610\text{ kN}, M_y = 4575\text{ kNm}, M_t = -0.19\text{ kNm}$
	$t = 400.0\text{ cm}$	LC 912:
	$L = 20.0\text{ m}$	$V_z = 660\text{ kN}, M_y = 4950\text{ kNm}, M_t = -50.20\text{ kNm}$
	$A_{s1} = 60\text{ cm}^2$	LC 913:
	$A_{s2} = 60\text{ cm}^2$	$V_z = 710\text{ kN}, M_y = 5325\text{ kNm}, M_t = 99.78\text{ kNm}$

Table 21.2: Results

Result	SOF (FEM).	Ref.
$\Delta\sigma_{s,eq}(N^*)\text{ [MPa]}$	74.04	76.98
$f_{cd,fat}\text{ [MPa]}$	17.06	17.0567
$\sigma_{cd,max,eq,_{TOP}}\text{ [MPa]}$	$\leq 14.33$	$\leq 14.33$
$\sigma_{cd,max,eq,_{shear\ cut}}\text{ [MPa]}$	$\leq 10.39$	$\leq 10.35$
$\frac{\Delta\sigma_{Rsk}(N^*)}{\gamma_{s,fat}}\text{ [MPa]}$	152.17	152.2

## 21.4 Design Process<sup>1</sup>

Design with respect to DIN EN 1992-1-1/NA [11] [2]:<sup>2</sup>

**STEP 1:** Material

Concrete: C 35/45

$$f_{ck} = 35 \text{ N/mm}^2$$

$$\gamma_c = 1.50$$

$$f_{cd} = \alpha_{cc} \cdot f_{ck} / \gamma_c = 0.85 \cdot 35 / 1.5 = 19.83 \text{ MPa}$$

**STEP 2:** Cross-section

$$1/W_{V_z} = 0.8177 \text{ 1/m}^2$$

$$1/W_{V_y} = 0.371 \text{ 1/m}^2$$

$$1/W_T = 0.3448 \text{ 1/m}^3$$

Minimum reinforcements:

$$A_{s1} = A_{s2} = 6 \cdot 10 = 60 \text{ cm}^2$$

$$A_{sl} = 8.22 \text{ cm}^2/\text{m}$$

**STEP 3:** Load Actions:

Permanent: Loadcase 1

Variable: Loadcase 2, 3

For the determination of the combination calculatioric forces and moments the following superposition types are chosen:

- Quasi permanent combination for serviceability - MAXP
- Frequent combination for serviceability - MAXF

The following combination of actions scenario is investigated for serviceability:

- LC 911 G  
MAXP + MY : 1.00 \* G
- LC 912 G+2  
MAXF + MY : 1.00 \* G +  $\psi_1$  \* LC 2
- LC 913 G+3  
MAXF + MY : 1.00 \* G +  $\psi_1$  \* LC 3

<sup>1</sup>The tools used in the design process are based on steel stress-strain diagrams, as defined in [2] 3.3.6: Fig. 3.10

<sup>2</sup>The sections mentioned in the margins refer to DIN EN 1992-1-1/NA [11], [2], unless otherwise specified.

3.1: Concrete

Tab. 3.1: Strength for concrete

(NDP) 2.4.2.4: (1), Tab. 2.1DE: Partial factors for materials

3.1.6: (1)P, Eq. (3.15):  $\alpha_{cc} = 0.85$  considering long term effects

$1/W_{V_i}$ : Shear force resistance, calculated by using BEM

$1/W_T$ : Torsional resistance, calculated by using BEM

$A_{sl}$ : Longitudinal

$A_{sl}$ : Shear links

6.8.3: (2)P: Fatigue

The basic combination of the non-cyclic load is similar to the definition of the frequent combination for serviceability:

$$\sum_{j \geq 1} G_{k,j} + P + \psi_{1,1} Q_{k,1} + \sum_{i > 1} \psi_{2,i} Q_{k,i}$$

Combination calculative forces and moments at  $x = 5.0 \text{ m}$ :

LC	$V_y \text{ [kN]}$	$V_z \text{ [kN]}$	$M_y \text{ [kNm]}$	$M_t \text{ [kNm]}$
911	0	610	4575	-0.189
912	0	660	4950	-50.20
913	0	710	5325	99.78

**STEP 4:** Calculation of stresses at  $x = 5.0 \text{ m}$  :

The resistance of structures to fatigue shall be verified in special cases.

6.8.1 (1)P: Verification conditions

This verification shall be performed separately from concrete and steel.

The following calculation corresponds to LC 911.

$\tau_Q$ : shear stresses resulting from shear force

$$\tau_Q = 1/W_{V_y} \cdot Q_y + 1/W_{V_z} \cdot Q_z$$

where  $Q_y$  and  $Q_z$  are calculated through a proportionate factor  $f_v$ , depending on the lever arm of internal forces and the elastic part of  $V_y$  and  $V_z$ .

The proportionate factor  $f_v$  is obtained from the internal lever in cracked condition to the un-cracked condition.

$$V_I = \sqrt{V_y^2 + V_z^2} = \sqrt{0^2 + 610^2} = 610 \text{ kN}$$

$$V_{II} = \sqrt{\left(\frac{V_y}{z_{y,II}}\right)^2 + \left(\frac{V_z}{z_{z,II}}\right)^2}$$

$$V_{II} = \sqrt{\left(\frac{0}{3.369}\right)^2 + \left(\frac{610}{1.528}\right)^2} = 399.21 \text{ kN}$$

$$f_v = \min\left(1, \frac{\left|\frac{V_I}{z_0}\right|}{V_{II}}\right) = \min\left(1, \frac{\left|\frac{610}{1.782}\right|}{399.21}\right) = 0.8576$$



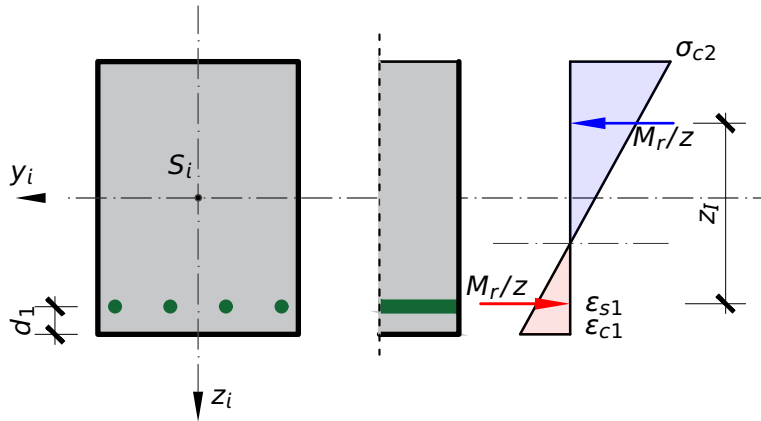

Figure 21.2: Stress distribution in un-cracked state -  $z_I$

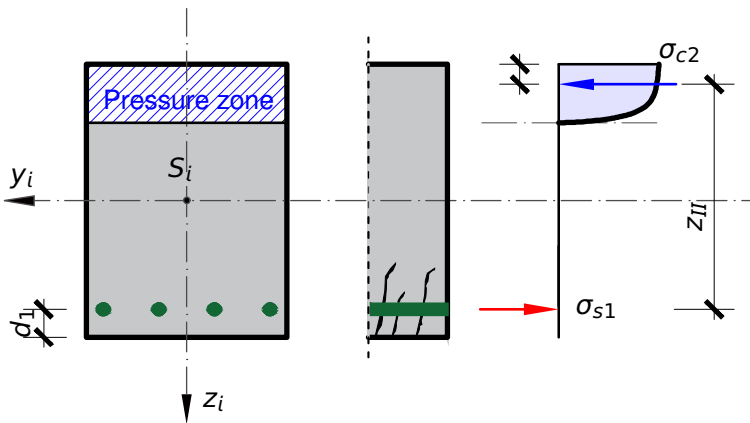

Figure 21.3: Stress distribution in cracked state -  $z_{II}$

$$Q_y = f_V \cdot V_y = 0.8576 \cdot 0.0 = 0.0 \text{ kN}$$

$$Q_z = f_V \cdot V_z = 0.8576 \cdot 610 = 523.149 \text{ kN}$$

$$\tau_Q = 0.371 \cdot 0.0 + 0.8177 \cdot 523.149 = 427.770 \cdot 10^{-3} \text{ MPa}$$

$$\tau_T = -1/W_T \cdot M_t = -0.344484 \cdot -0.189 = 0.065 \cdot 10^{-3} \text{ MPa}$$

$$\tau = \tau_Q + \tau_T = 427.770 \cdot 10^{-3} + 0.065 \cdot 10^{-3} = 427.835 \cdot 10^{-3} \text{ MPa}$$

$$\tau_{II} = (\tau_Q + \tau_T) \cdot (1.0 + \cot^2 \theta)$$

$$\sigma_{II} = \frac{\tau_{II}}{\cot \theta + \cot \alpha}$$

A rather nasty problem is the evaluation of the shear. The DIN design code allows a simple solution based on a corrected value for the inclination of the compressive struts:

$$\tan \theta_{fat} = \sqrt{\tan \theta}$$

Unfortunately it is nearly impossible to keep this value from the shear design for all individual shear cuts or transform it to different load com-

$\tau_T$ : shear stresses resulting from torsion

$\tau_{II}, \sigma_{II}$ : principal stresses

$\theta$ : angle of compression struts  
 $\alpha$ : angle of shear reinforcement  
 $\alpha = 90^\circ \Rightarrow \sin \alpha = 1.0, \cot \alpha = 0.0$

6.8.2(3): In the design of shear reinforcement the inclination of the compressive struts  $\theta_{fat}$  may be calculated by Eq. 6.65

6.8.2(3): Eq. 6.65:  $\tan \theta_{fat}$

binations and reinforcement distributions for the fatigue stress check. **AQB** uses instead a fixed value of 4/7 for the tangents. The user may overwrite this value however with any desired value.

$$\tan \theta = 4/7 \Rightarrow \cot \theta = 7/4 = 1.75$$

$$\tan \theta_{fat} = \sqrt{4/7} = 0.756$$

$$\cot \theta_{fat} = \sqrt{7/4} = 1.3229$$

$$\tau_{II} = (427.770 \cdot 10^{-3} + 0.065 \cdot 10^{-3}) \cdot (1.0 + 1.75^2)$$

$$\tau_{II} = 1740.048 \cdot 10^{-3} \text{ MPa}$$

$$\sigma_{II} = \frac{1740.048 \cdot 10^{-3}}{1.75 + 0.0} = 994.313 \cdot 10^{-3} \text{ MPa}$$

$\sigma_{sl}$ : steel stresses

$$\sigma_{sl} = \frac{f_Q \cdot \tau_Q}{(\cot \theta_{fat} + \cot \alpha) \cdot \sin \alpha} + \frac{f_T \cdot \tau_T}{\cot \theta_{fat}}$$

$$A_{sl/cut} = A_{sl} / 2 = 4.11 \text{ cm}^2/m$$

$$f_T = \frac{B_0 \cdot f_r}{A_{sl/cut}}, \quad \text{and} \quad f_Q = \frac{B_b \cdot f_r}{A_{sl/cut}}$$

where  $f_T$  and  $f_Q$  are factors expressing the shear links reinforcement ratios. They are depending on  $f_r$ , a factor for total reinforcement,  $B_0$ , the width of the cut and  $B_b$ , the total width of the cut. Since in this case it is a box cross-section and taking into account the position of the cut, we get that  $B_0 = B_b = 0.4 \text{ m}$ .

The factor  $f_r$  has only two possible values  $f_r = 1.0$  or  $f_r = 2.0$ . It depends on the cross-section and the shear cut. If  $B_{max} < B_0$  then  $f_r = 2.0$ .

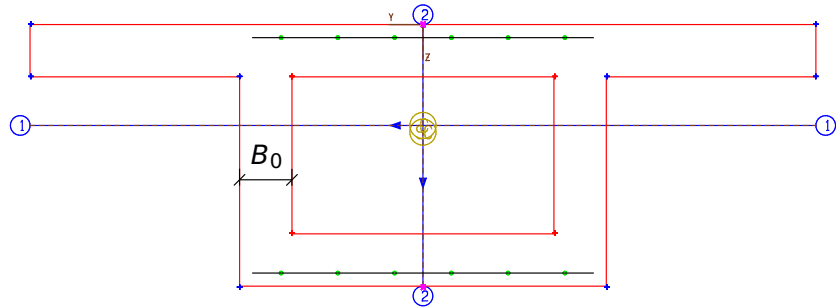

Figure 21.4: Cross-section Overview

$$f_T = \frac{0.4 \cdot 1.0}{4.11 \cdot 10^{-4}} = 973.532 \quad \text{and} \quad f_Q = \frac{0.4 \cdot 1.0}{4.11 \cdot 10^{-4}} = 973.532$$

$$\sigma_{sl} = \frac{973.532 \cdot 427.770 \cdot 10^{-3}}{(1.3229 + 0.0) \cdot 1.0} + \frac{973.532 \cdot 0.065 \cdot 10^{-3}}{1.3229}$$

$$\sigma_{sl} = 314.882 \text{ MPa}$$

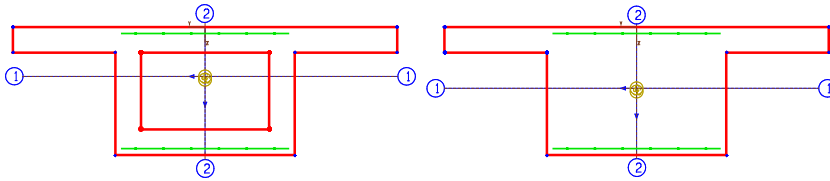

Figure 21.5: Factor of total reinforcement,  $f_r = 1.0$  (left),  $f_r = 2.0$  (right)

Accordingly, we calculate the stresses for the rest of the loadcases. For each loadcase the stresses are calculated for two cases, for  $\tau_T$  and for  $-\tau_T$ , in order to determine the most unfavorable case. The results are presented in Table 21.4

Table 21.4: Calculation of Stresses by using BEM

LC	$Q_Z$ [kN]	$\tau_Q$ [MPa]	$\tau_T \cdot 10^{-3}$ [MPa]	$\tau$ [MPa]	$\tau_{II}$ [MPa]	$\sigma_{II}$ [MPa]	$\sigma_{sl}$ [MPa]
911	523.14	0.428	0.065	0.427	1.740	0.993	314.88
			-0.065	0.427	1.739	0.993	<b>314.78</b>
912	566.03	0.463	17.31	0.480	1.952	1.115	353.38
			-17.31	0.4455	1.8120	1.0346	327.90
913	608.911	0.498	-34.41	0.4635	1.8851	1.0764	341.12
			34.41	0.5323	2.1649	1.2362	<b>391.7</b>

From the table, the minimum and maximum value of the steel stress is determined:

- Max.  $\sigma_{sl} = 391.77 \text{ MPa}$
- Min.  $\sigma_{sl} = 314.79 \text{ MPa}$

As the exact fatigue stress check is not available, the simplified methods according to DIN EN 1992-1-1/NA (Sect. 6.8, Fatigue) are selected via the coefficients  $\lambda_s$ ,  $\lambda_t$ ,  $\lambda_l$ ,  $\lambda_c$ .

The admissible sways of the damage equivalent stress range for the shear links are obtained, as follows:

$$\Delta\sigma_{s,equ}(N^*) = \lambda_l \cdot (\sigma_{sl,max} - \sigma_{sl,min}) = 1.0 \cdot (391.77 - 314.79)$$

$$\Delta\sigma_{s,equ}(N^*) = 76.98 \text{ MPa}$$

For reinforcing steel adequate fatigue resistance should be assumed, if the following is satisfied:

$$\gamma_{F,fat} \cdot \Delta\sigma_{s,equ}(N^*) \leq \frac{\Delta\sigma_{Rsk}(N^*)}{\gamma_{s,fat}}$$

$\lambda_l$ : Coeff. equiv. stress range shear links, here input as 1.0

6.8.2 (2): Eq. 6.64:  $\eta$  factor for effect of different bond behaviour

$\eta = \frac{A_s + A_p}{A_s + A_p \sqrt{\epsilon_s \cdot \phi_s / \phi_p}}$ , since  $A_p = 0$  (no prestress)  $\Rightarrow \eta = 1.0$ , thus no increase of calculated stress range in the reinforcing steel

6.8.5 (3): Eq. 6.71: Verification using damage equivalent stress range

(NDP) 6.8.4 (6): Table 6.3DE: Parameters for fatigue strength curves for reinforcing steel  $\Delta\sigma_{Rsk}(N^*) = 175$  for straight/bent bars and  $N^* = 10^6$  cycles (NDP) 2.4.2.3 (1): Partial factor for fatigue loads  $\gamma_{F,fat} = 1.0$

(NDP) 2.4.2.4 (1): Partial factors for materials  $\gamma_{s,fat} = 1.15$

$$1.0 \cdot 76.98 \leq \frac{175}{1.15}$$

$$\Delta\sigma_{s,equ}(N^*) = 76.98 \leq 152.2 \text{ MPa}$$

If a coefficient  $\lambda_l = 2.0$  is input for the shear links, resulting in a stress range of  $\Delta\sigma_{s,equ}(N^*) = 2 \cdot 76.98 = 153.97 \text{ MPa}$ , a star (\*) will be printed in the output next to the shear link stress range, denoting that the limit value of  $152.2 \text{ MPa}$  has been exceeded.

(NDP) 6.8.7 (1): Eq. 6.76:  $f_{cd,fat}$   
 $k_1 = 1.0$   
 3.1.2 (6): Eq. 3.2:  $\beta_{cc}(t_0)$   
 $\beta_{cc}(t_0) = e^{5 \cdot (1 - \sqrt{28/t})} = 1.0$

The design fatigue strength of concrete is determined by:

$$f_{cd,fat} = k_1 \cdot \beta_{cc}(t_0) \cdot f_{cd} \cdot \left(1 - \frac{f_{ck}}{250}\right)$$

$$f_{cd,fat} = 1.0 \cdot 1.0 \cdot 19.83 \cdot \left(1 - \frac{35}{250}\right) = 17.0567 \text{ MPa}$$

In the case of the compression struts of members subjected to shear, the concrete strength  $f_{cd,fat}$  should be reduced by the strength reduction factor  $\nu_1$  according to 6.2.3(3).

(NDP) 6.8.7 (3): Verification of concrete under compression or shear

(NDP) 6.2.3 (3):  $\nu_1, \nu_2$

$$\nu_2 = \left(1.1 - \frac{f_{ck}}{500}\right) \leq 1.0$$

$$\nu_2 = \left(1.1 - \frac{35}{500}\right) = 1.03 \rightarrow \nu_2 = 1.0$$

$$\nu_1 = 0.75 \cdot \nu_2$$

$$\nu_1 = 0.75 \cdot 1.0 = 0.75$$

$$\Rightarrow f_{cd,fat,red} = 0.75 \cdot 17.0567 = 12.7925 \text{ MPa}$$

A satisfactory fatigue resistance may be assumed, if the following condition is fulfilled:

6.8.7 (1): Eq. 6.72 - 6.75

$$E_{cd,max,equ} + 0.43 \cdot \sqrt{1 - R_{equ}} \leq 1$$

$$\frac{\sigma_{cd,max,equ}}{f_{cd,fat,red}} + 0.43 \cdot \sqrt{1 - \frac{\sigma_{cd,min,equ}}{\sigma_{cd,max,equ}}} \leq 1$$

$$\sigma_{cd,max,equ} \leq f_{cd,fat,red} \cdot \left(1.0 - 0.43 \cdot \sqrt{1 - \frac{\sigma_{cd,min,equ}}{\sigma_{cd,max,equ}}}\right)$$

$$\sigma_{cd,max,equ} \leq 12.7925 \cdot \left(1.0 - 0.43 \cdot \sqrt{1 - \frac{0.9933}{1.2362}}\right)$$

$$\sigma_{cd,max,equ} = 1.2362 \leq 10.35 \text{ MPa}$$

Accordingly the above verification is done for the minimum and maximum nonlinear stresses of concrete, as calculated from **AQB** Fig. 21.6, at the defined 'TOP' point of the cross-section.

$$\sigma_{cd,max,equ} \leq f_{cd,fat} \cdot \left(1.0 - 0.43 \cdot \sqrt{1 - \frac{\sigma_{cd,min,equ}}{\sigma_{cd,max,equ}}}\right)$$

$$\sigma_{cd,max,eq} \leq 17.0567 \cdot \left( 1.0 - 0.43 \cdot \sqrt{1 - \frac{5.69}{6.60}} \right)$$

$$\sigma_{cd,max,eq} = 6.60 \leq 14.33 \text{ MPa}$$

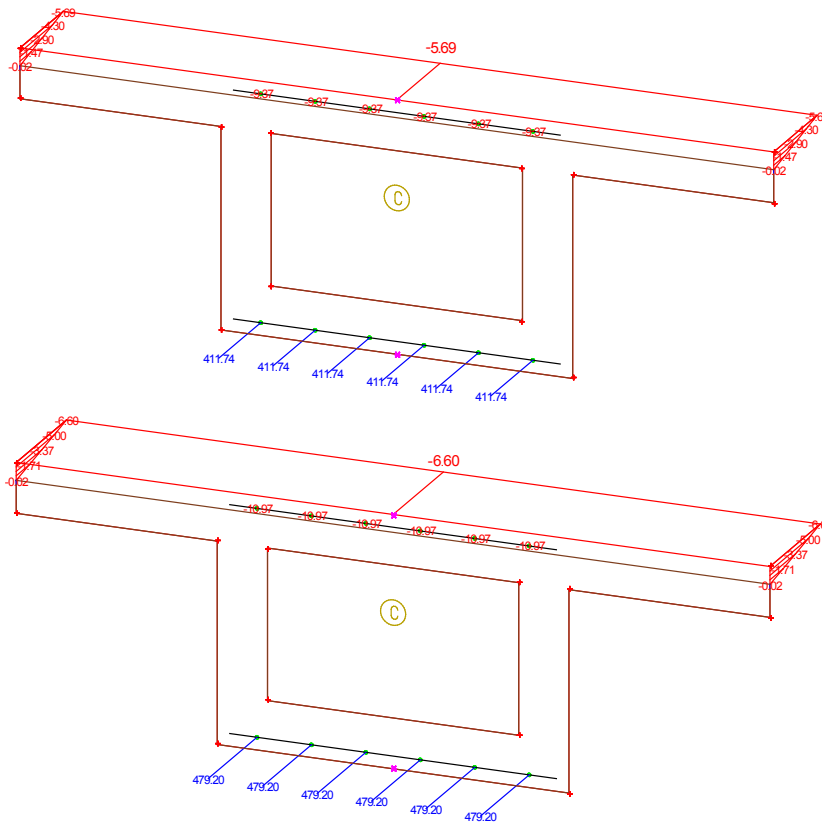

Figure 21.6: Min/Max. Nonlinear Stresses of Concrete at "TOP" Point (BEM)

Stress limitation:

$$\sigma_{max,t} = k_3 \cdot f_{yk} = 0.80 \cdot 500 \text{ MPa} = 400 \text{ MPa}$$

7.2 (5)

## 21.5 Conclusion

This example shows the verification of a reinforced concrete beam to fatigue. It has been shown that **AQB** follows the fatigue verification procedure, as proposed in DIN EN 1992-1-1/NA [11] [2]. The insignificant deviation arises from the fact that the benchmark (reference) results have been calculated by using the BEM analysis. By introducing the FEM analysis, AQUA calculates now the  $1/W_{Vz}$ ,  $1/W_{Vy}$  and  $1/W_T$  values more accurate.

## 21.6 Literature

- [2] F. Fingerloos, J. Hegger, and K. Zilch. *DIN EN 1992-1-1 Bemessung und Konstruktion von Stahlbeton- und Spannbetontragwerken - Teil 1-1: Allgemeine Bemessungsregeln und Regeln für den Hochbau*. BVPI, DBV, ISB, VBI. Ernst & Sohn, Beuth, 2012.
  - [11] *DIN EN 1992-1-1/NA:2013-04: Eurocode 2: Design of concrete structures, Part 1-1/NA: General rules and rules for buildings - Nationaler Anhang Deutschland, Ersatz für DIN EN 1992-1-1/NA:2011-01 und DIN EN 1992-1-1/NA Berichtigung 1:2012-06*. DIN. 2013.
-

## 22 DCE-EN20: Design of a Steel I-section for Bending, Shear and Axial Force

### Overview

<b>Design Code Family(s):</b>	EN
<b>Design Code(s):</b>	EN 1993-1-1
<b>Module(s):</b>	AQB
<b>Input file(s):</b>	<a href="#">usage_interact.dat</a>

### 22.1 Problem Description

The problem consists of a steel I section, as shown in Fig. 22.1. The cross-section is loaded with bending, shear and axial force. The required result is the utilization of the ultimate bearing capacity. The formulas provided in the Eurocode for that purpose are not generally applicable for all types of sections and do not allow a direct evaluation of this value, so it is common, that software implementations will deviate in some parts from the suggested procedure.

First it will be shown that a loading below the ultimate capacity will be covered by selected software even if deviations in the applied formulas will affect the expected results slightly. Then it will be demonstrated that an advanced analysis using additional features within the provisions of the design code allows a better approach to the ultimate capacity.

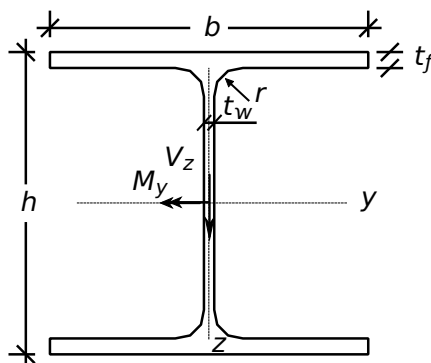

Figure 22.1: Problem Description

Table 22.1: Model Properties

Material Properties	Geometric Properties	Loading
S 235	HEM 500	$V_z = 1400 \text{ kN}$
$\gamma_{M0} = 1.00$	$b = 306 \text{ mm}$	$M_y = 450 \text{ kNm}$
	$h = 524 \text{ mm}$	$N = -5000 \text{ kN}$
	$t_f = 40 \text{ mm}, t_w = 21 \text{ mm}$	
	$r = 27 \text{ mm}$	
	$A = 344.298 \text{ cm}^2$	Sectional Class 1

## 22.2 Reference Solution

As significant shear and axial forces are present allowance should be made for the effect of both shear force and axial force on the resistance moment. The content of this problem is covered by the following parts of EN 1993-1-1:2005 [7]:

- Structural steel (Section 3.2 )
- Resistance of cross-sections (Section 6.2)

## 22.3 Model and Results

The section, a HEM 500, with properties as defined in Table 22.1, is to be designed for an ultimate moment  $M_y$ , a shear force  $V_z$  and an axial force  $N$ , with respect to EN 1993-1-1:2005 [7]. The utilisation level of allowable plastic forces are calculated and compared to software results. The results are given in Table 22.2.

Table 22.2: Results

Result	SOF.	Ref.
Util. level $N$	0.618	0.618
Util. level $N_{Ed}/N_{V,Rd}$	0.712	0.712
Util. level $V_z$	0.797	0.797
Util. level $M_y$	0.270	0.270
Total util. level $M_{y,red}$ (EN 1993-1-1)	0.952	0.846



## 22.4 Design Process<sup>1</sup>

The calculation steps of the reference solution are presented below. Neither the axial force (see EN 1993-1-1, 6.2.9.1 (4)) nor the shear force (see EN 1993-1-1, 6.2.10) can be neglected.

### Material:

Structural Steel S 235

$$f_y = 235 \text{ N/mm}^2$$

### Cross-sectional properties:

$$W_{pl,y} = 7094.2 \text{ cm}^2$$

$$A_{V,z} = A - 2 \cdot b \cdot t_f + (t_w + 2 \cdot r) \cdot t_f \text{ but not less than } \eta \cdot h_w \cdot t_w$$

$$h_w = h - 2 \cdot t_f = 44.4 \text{ cm}$$

$$A_{V,z} = 129.498 \text{ cm}^2 > 1 \cdot 44.4 \cdot 2.1 = 93.24$$

$$a_{V,z} = \frac{A_{V,z}}{A} = \frac{129.5}{344.3} = 0.376$$

$$A_V = A - 2 \cdot b \cdot t_f = 99.498 \text{ cm}^2$$

$$a = \frac{A_V}{A} = \frac{99.5}{344.3} = 0.289$$

$$V_{pl,Rd,z} = \frac{129.498 \cdot 235 / \sqrt{3}}{1.00} = 1757 \text{ kN}$$

$$M_{c,Rd} = \frac{W_{pl,y} \cdot f_y}{\gamma_{M0}} = 1667 \text{ kNm}$$

Where the shear and axial force are present allowance should be made for the effect of both shear force and axial force on resistance moment.

Provided that the design value of the shear force  $V_{Ed}$  does not exceed the 50% of the design plastic shear resistance  $V_{pl,Rd}$  no reduction of the resistances for bending and axial force need to be made.

$$V_{Ed} \leq 0.5 \cdot V_{pl,Rd}$$

$$\frac{V_{Ed}}{V_{pl,Rd,z}} = 0.797 > 0.5$$

→ shear resistance limit exceeded

Provided that the design value of the shear force  $V_{Ed}$  exceeds the 50% of the design plastic shear resistance  $V_{pl,Rd,z}$ , the design resistance of the cross-section to combinations of moment and axial force should be calculated using a reduced yield strength  $(1 - \rho) \cdot f_y$  for the shear area. Therefore all following formulas will be modified for the shear force allowance.

<sup>1</sup>The sections mentioned in the margins refer to EN 1993-1-1:2005 [7] unless otherwise specified.

Plastic section modulus of HEM 500 w.r.t. y-

6.2.6 (3)a: The shear area  $A_{V,z}$  may be taken as follows for rolled I-sections with load parallel to the web

$\eta$  may be conservatively taken equal to 1.0

Partial factor  $\gamma_{M0} = 1.0$

$$6.2.9.1 (5): a = \frac{A - 2 \cdot b \cdot t_f}{A}$$

6.2.6 (3)a: The shear area  $A_{V,z}$  may be taken as follows for rolled I-sections with load parallel to the web

6.2.5 (2), Eq. 6.13: The design resistance for bending, for Class 1 cross-section

6.2.10 (1): Bending, shear and axial force

6.2.10 (2)

6.2.10 (3): Bending shear and axial force

6.2.10 (3) the design resistance should be calculated using a reduced yield strength  $(1 - \rho) \cdot f_y$  for the **shear area**

$$\rho = \left( \frac{2 \cdot V_{Ed}}{V_{pl,Rd,z}} - 1 \right)^2 = 0.352$$

6.2.8 (5): Eq. 6.30: The reduced design plastic resistance moment allowing for shear force may alternatively be obtained for I-sections with equal flanges and bending about major axis

$$M_{y,V,Rd} = \frac{\left[ W_{pl,y} - \frac{\rho \cdot A_w^2}{4 \cdot t_w} \right] \cdot f_y}{\gamma_{M0}} = 1581 \text{ kNm}$$

$$\frac{M_y}{M_{y,V,Rd}} = 0.277$$

$$\frac{M_y}{M_{c,Rd}} = 0.270 \text{ with no reduction}$$

6.2.4 (2), Eq. 6.10: The design resistance for compression

$$N_{pl,Rd} = \frac{A \cdot f_y}{\gamma_{M0}} = 8091 \text{ kN}$$

$$N_{V,Rd} = N_{pl,Rd} \cdot (1 - a_{V,z} \cdot \rho)$$

$$N_{V,Rd} = 7018.6 \text{ kN}$$

$$n_V = \frac{N_{Ed}}{N_{V,Rd}} = 0.712$$

$$\frac{N_{Ed}}{N_{pl,Rd}} = 0.618 \text{ with no reduction}$$

6.2.9.1 (1): Bending and axial force - Class 1 and 2 cross-sections

Where an axial force is present, allowance should be made for its effect on the plastic moment resistance.

6.2.9.1 (4): For doubly symmetrical I-sections, allowance need not to be made for the effect of the axial force on the plastic resistance moment about the y-y axis when the criteria are satisfied.

$$N_{Ed} > \min \left\{ \frac{0.25 \cdot N_{V,Rd}}{0.5 \cdot h_w \cdot t_w \cdot f_y \cdot (1 - \rho)} \right.$$

$$\left. N_{Ed} = 5000 > \min \left\{ \begin{array}{l} 1754.7 \text{ kN} \\ 709.5 \text{ kN} \end{array} \right. \right.$$

→ consideration of axial force in interaction

6.2.9.1 (5): Eq. 6.36-6.38: reduced design plastic resistance moment allowing for I-sections with equal flanges and bending about major axis.

$$M_{N,y,Rd} = M_{V,y,Rd} \cdot \frac{1 - n}{1 - 0.5 \cdot \alpha^*}$$

$$\text{and } M_{N,y,Rd} \leq M_{V,y,Rd}$$

$$n = \frac{N_{Ed}}{N_{V,Rd}} = 0.712$$

$$\alpha^* = \min \left\{ \frac{A - 2 \cdot b \cdot t_f}{A} = \frac{344.4 - 2 \cdot 30.6 \cdot 4}{344.4} = 0.289 \right.$$

$$\alpha^* = 0.289$$

$$M_{N,y,Rd} = 1581 \cdot \frac{1 - 0.712}{1 - 0.5 \cdot 0.289} = 531 \text{ kNm}$$

$$\frac{M_{y,Ed}}{M_{NV,y,Rd}} = \frac{450}{531} = 0.846$$

Alternative solution (see evaluation below):

$$M_{y,V,Rd} = \left( 7094 - \frac{0.352 \cdot 129.5^2}{4 \cdot 2.1} \right) \cdot f_y$$

$$M_{y,V,Rd} = 1501.8 \text{ kNm}$$

$$M_{N,y,Rd} = \frac{1 - 0.712}{1 - 0.5 \cdot 0.376} \cdot 1501 = 532 \text{ kNm}$$

$$\frac{M_{Ed}}{M_{N,y,Rd}} = \frac{450}{532} = 0.846$$

Using  $A_w = A_v = A_{vz}$  instead of three different values:  $93.2 \neq 99.5 \neq 129.5$

Hit: The reduction by the plastic bending resistance of the web may be obtained with a better precision.

## 22.5 Conclusion

Interaction formulas are not expected to be true for all cases [12]. Thus deviations are unavoidable.

The first reason of the deviation is that the interaction formulas are not linear. Thus an utilisation factor of 0.5 does not mean that the ultimate load is twice the current loading. If the utilisation factor of the normal force or the shear force become 1.0 or larger then the formulas are not applicable any more. So the utilisation formula should be rewritten from the original form of:

$$\frac{M}{M_{y,V,Rd}} \cdot \frac{1 - 0.5 \cdot \alpha}{\left(1 - \frac{N}{N_{V,Rd}}\right)} \leq 1.00 \quad (22.1)$$

to the completely equivalent form:

$$\frac{M}{M_{y,V,Rd}} \cdot (1 - 0.5 \cdot \alpha_{Vz}) + \frac{N}{N_{V,Rd}} \leq 1.00 \quad (22.2)$$

These are two different curves intersecting for the critical value of 1.0, but the singularity for the utilisation  $N/N_{V,Rd} = 1$  is avoided. The second formula yields a value of 0.956 with the EN reference data. The simplified interaction according to equation 6.2 of EN 1993-1-1 yields an utilisation value of 1.04. Program RUBSTAHL QST-I [12] yields an utilisation of 1.00.

The second reason for the deviations is that the software follows a more general principle and uses only a single value for the shear capacity as indicated in the last row of table 22.2. Thus the software has to select either the web only or the dog-bone-shape including parts of the flanges, as can be visualized in Fig. 22.2.

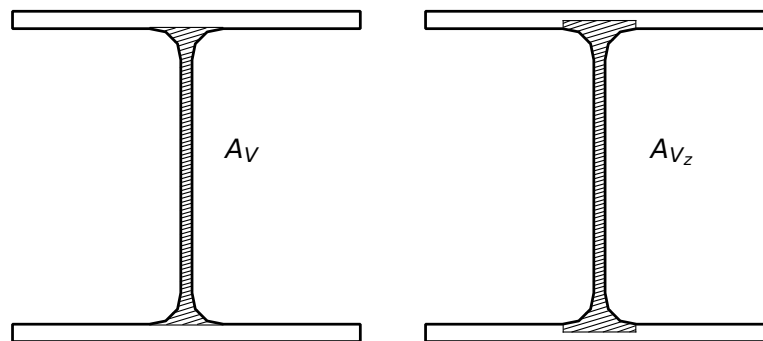

Figure 22.2: Different shear areas for steel section

These deviations become larger, if we try to find the true capacity of the section. It has to be noted, that most interaction formulas for shear and normal stress are working with partial areas and are not accounting for the true interaction of stresses. There are different possibilities in the literature and there are some numerical procedures by Katz [13] or Osterrieder [14] allowing for more detailed evaluations.

The solution with the optimization process from Osterrieder [14] yields a true utilisation factor of 0.93 for the given forces. Thus the true ultimate plastic force combination is:  $N = 5380 \text{ kN}$ ,  $V_z = 1505 \text{ kN}$ ,  $M_y = 483.9 \text{ kNm}$ . The software provides for these forces with the modified interaction formulas an utilisation of 1.08. If one follows strictly the design code, much higher values of about 2.7 are obtained, showing the strong non proportionality of those formulas.

The solution according to Katz [13] uses a non-linear analysis, thus we have finite strains and the hardening effect of the steel strain law is used, as indicated in EN 1993-1-5:2006 Appendix C.6 [15]. Then it is no problem to obtain even higher ultimate forces:  $N = 5800 \text{ kN}$ ,  $V_z = 1624 \text{ kN}$ ,  $M_y = 522 \text{ kNm}$ , giving a utilisation factor of 0.86 for the given loading. The normal and shear stress distribution in Figure 22.3 is obtained with a maximum compressive strain of  $-1.61\%$ .

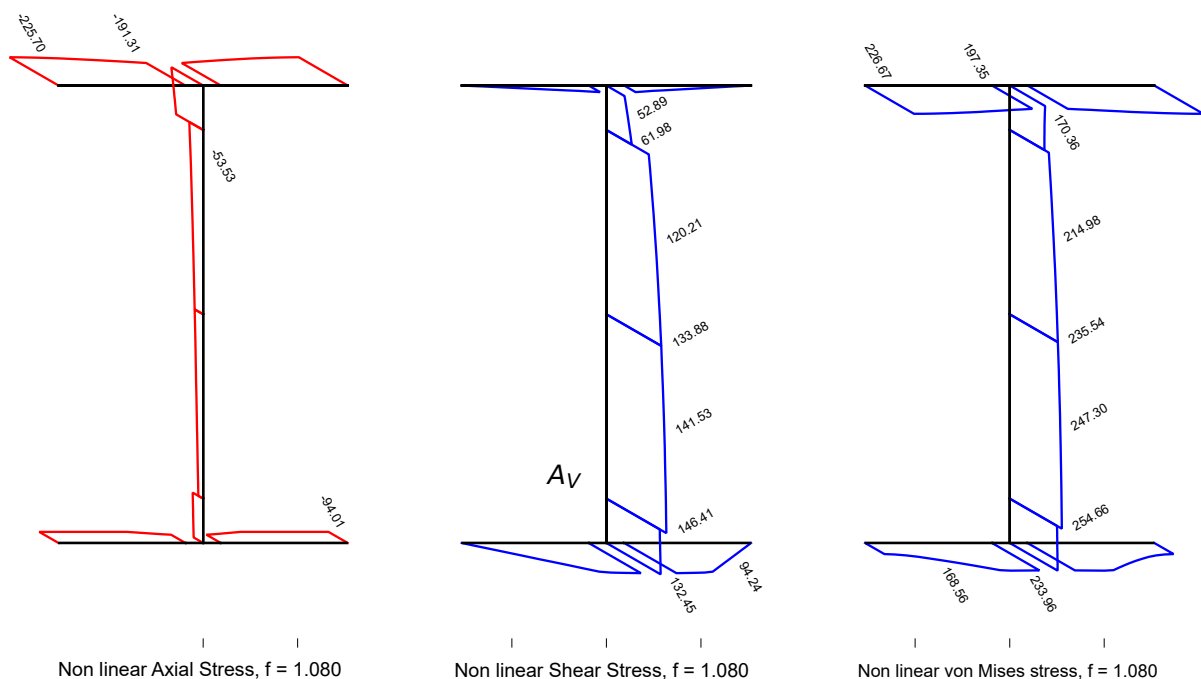

Figure 22.3: Non-linear normal and shear stress distribution

## 22.6 Literature

- [7] EN 1993-1-1: Eurocode 3: Design of concrete structures, Part 1-1: General rules and rules for buildings. CEN. 2005.
- [12] R. Kindmann and U. Krüger. *Stahlbau, Teil 1: Grundlagen*. Ernst & Sohn, 2015.
- [13] C. Katz. "Fließzonentheorie mit Interaktion aller Stabschnittgrößen bei Stahltragwerken". In: *Stahlbau* (1997).
- [14] P. Osterrieder. "Plastic Bending and Torsion of Open Thin-Walled Steel Members". In: *Proceedings of EUROSTEEL 2005, 4th European Conference on Steel and Composite Structures* (Maastricht, 2005).
- [15] DIN EN 1993-1-5: Eurocode 3: Design of steel structures, Part 1-5: Plated structural elements - German version EN 1993-1-1:2006 + AC:2009. CEN. 2010.



## 23 DCE-EN21: Real Creep and Shrinkage Calculation of a T-Beam Prestressed CS

### Overview

<b>Design Code Family(s):</b>	EN
<b>Design Code(s):</b>	EN 1992-1-1
<b>Module(s):</b>	CSM
<b>Input file(s):</b>	<a href="#">real_creep_shrinkage.dat</a>

### 23.1 Problem Description

The problem consists of a simply supported beam with a T-Beam cross-section of prestressed concrete, as shown in Fig. 23.1. The nodal displacement is calculated considering the effects of real creep and shrinkage, also the usage of custom (experimental) creep and shrinkage parameters is verified, the custom (experimental) parameter is taken from fib Model Code 2010 [16].

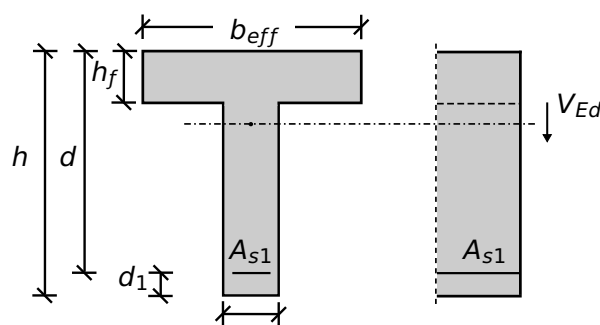

Figure 23.1: Problem Description

### 23.2 Reference Solution

This example is concerned with the calculation of creep and shrinkage on a prestressed concrete CS, subject to horizontal prestressing force. The content of this problem is covered by the following parts of EN 1992-1-1:2004 [6]:

- Creep and Shrinkage (Section 3.1.4)
- Annex B: Creep and Shrinkage (Section B.1, B.2)

The time dependant displacements are calculated by multiplying the length of the beam with the creep ( $\epsilon_{cc}$ ) and shrinkage ( $\epsilon_{cs}$ ) strain:

- the creep deformation of concrete is calculated according to (EN 1992-1-1, 3.1.4, Eq. 3.6)
- the total shrinkage strain is calculated according to (EN 1992-1-1, 3.1.4, Eq. 3.8)

### 23.3 Model and Results

The benchmark 21 is here to show the effects of real creep on a prestressed concrete simply supported beam. The analysed system can be seen in Fig. 23.4 with properties as defined in Table 23.1. The

tendon geometry is simplified as much as possible and modelled as a horizontal force, therefore tendons are not subject of this benchmark. The beam consists of a T-Beam cs and is loaded with a horizontal prestressing force from time  $t_1 = 100$  days to time  $t_2 = 300$  days. The self-weight is neglected. A calculation of the creep and shrinkage is performed in the middle of the span with respect to EN 1992-1-1:2004 [6]. The calculation steps are presented below and the results are given in Table 23.2 for the calculation with CSM. For calculating the real creep and shrinkage (RCRE) an equivalent loading is used, see Fig. 23.2 and Fig. 23.3.

The time steps for the calculation are:

$$t_0 = 7 \text{ days}, \quad t_1 = 100 \text{ days}, \quad t_2 = 300 \text{ days}, \quad t_\infty = 30 \text{ years}$$

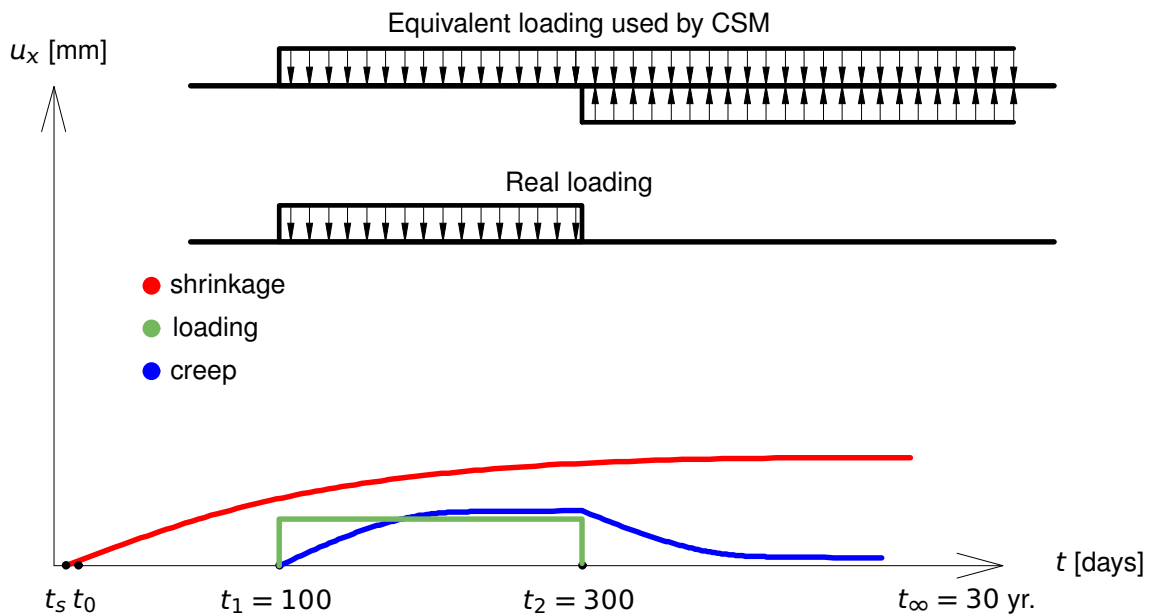

Figure 23.2: Creep, shrinkage and loading displacements

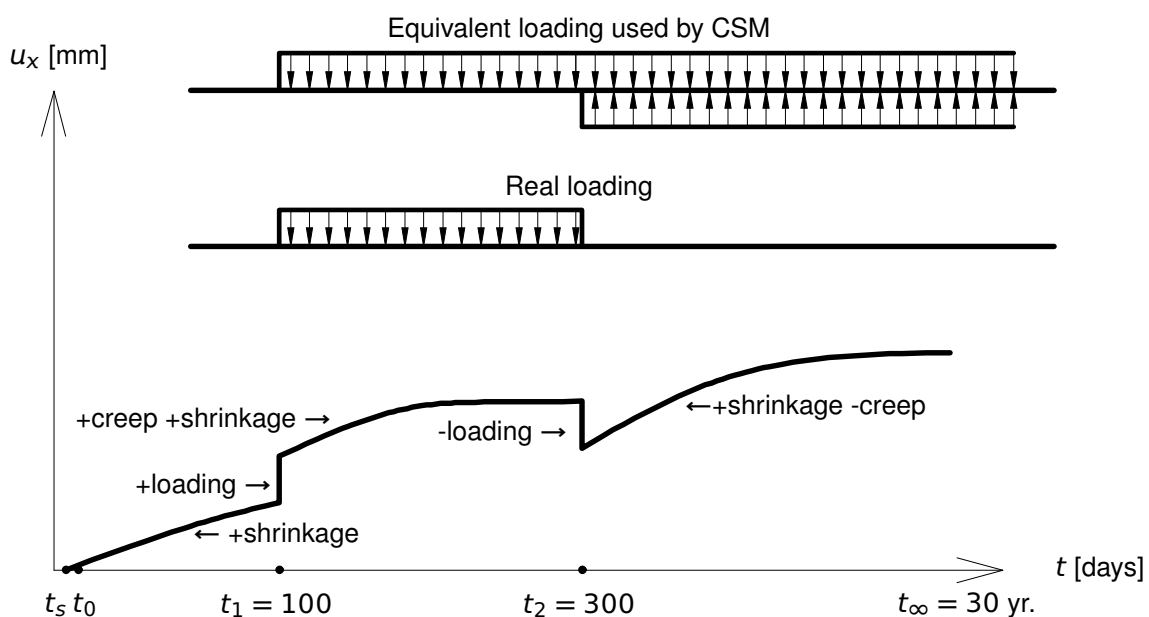

Figure 23.3: Equivalent loading and displacement for real creep and shrinkage (RCRE)



The benchmark contains next calculation steps:

1. Calculating the shrinkage displacements before loading.
2. Calculating the displacements when loading occurs at time  $t_1 = 100$  days.
3. Calculating the displacements (creep and shrinkage) at time before the loading is inactive ( $t_2 \approx 300$  and  $t_2 < 300$  days).
4. Calculating the displacements at time when the loading is inactive ( $t_2 \approx 300$  and  $t_2 > 300$  days).
5. Calculating the displacements at time  $t_3 = 30$  years.

Table 23.1: Model Properties

Material Properties	Geometric Properties	Loading (at $x = 10$ m)	Time
C 35/45	$h = 120$ cm	$N_p = -900.0$ kN	$t_0 = 7$ days
Y 1770	$b_{eff} = 280.0$ cm		$t_s = 3$ days
RH = 80	$h_f = 40$ cm		
	$b_w = 40$ cm		
	$L = 20.0$ m		

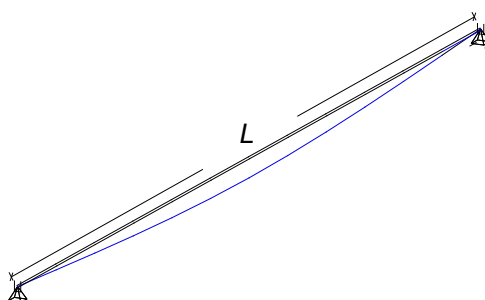

Figure 23.4: Simply Supported Beam

Table 23.2: Results

Result	CSM [mm]	Ref [mm].
$\Delta l_{4015}$	-0.688	-0.688
$\Delta l_{4020}$	-0.847	-0.8431
$\Delta l_{4025}$	-1.455	-1.45314
$\Delta l_{4030}$	-1.298	-1.29814
$\Delta l_{4035}$	-2.167	-2.08

## 23.4 Design Process<sup>1</sup>

### Design with respect to EN 1992-1-1:2004 [6]:<sup>2</sup>

Material:

3.1: Concrete

Concrete: C 35/45

3.1.2: Tab. 3.1:  $E_{cm}$ ,  $f_{ck}$  and  $f_{cm}$  for C 35/45

$$E_{cm} = 34077 \text{ N/mm}^2$$

$$f_{ck} = 35 \text{ N/mm}^2$$

$$f_{cm} = 43 \text{ N/mm}^2$$

3.3: Prestressing Steel

Prestressing Steel: Y 1770

Load Actions:

Self weight per length is neglected:  $\gamma = 0 \text{ kN/m}$  (to simplify the example as much as possible)

At  $x = 10.0 \text{ m}$  middle of the span:

$$N_{Ed} = -900 \text{ kN}$$

$$A = 280 \cdot 40 + 60 \cdot 80 = 16000 \text{ cm}^2$$

**Calculation of stresses** at  $x = 10.0 \text{ m}$  midspan:

$\sigma_c$  stress in concrete

$$\sigma_c = \frac{N_{Ed}}{A} = \frac{-900}{16000} = -0.05625 \text{ kN/cm}^2 = -0.5625 \text{ N/mm}^2$$

#### 1) Calculating the shrinkage displacements before loading

- Calculating creep:

According to EN 1992-1-1 the creep deformation of concrete for a constant compressive stress  $\sigma_c$  applied at a concrete age  $t_0$  is given by:

$$\epsilon_{cc} = \phi(t, t_0) \cdot (\sigma_c / E_{cs})$$

Because  $\sigma_c = 0$  (before loading), creep deformation is neglected and  $\epsilon_{cc} = 0$ .

- Calculating shrinkage:

$t_0$  minimum age of concrete for loading  
 $t_s$  age of concrete at start of drying shrinkage  
 $t$  age of concrete at the moment considered

$$t_0 = 7 \text{ days}$$

$$t_s = 3 \text{ days}$$

$$t = 100 \text{ days}$$

$$t_{eff} = t - t_0 = 100 - 7 = 93 \text{ days}$$

3.1.4 (6): Eq. 3.8:  $\epsilon_{cs}$  total shrinkage strain

$$\epsilon_{cs} = \epsilon_{cd} + \epsilon_{ca}$$

3.1.4 (6): Eq. 3.9:  $\epsilon_{cd}$  drying shrinkage strain

$$\epsilon_{cd}(t) = \beta_{ds}(t, t_s) \cdot k_h \cdot \epsilon_{cd,0}$$

<sup>1</sup>The tools used in the design process are based on steel stress-strain diagrams, as defined in [6] 3.3.6: Fig. 3.10

<sup>2</sup>The sections mentioned in the margins refer to EN 1992-1-1:2004 [6], [2], unless otherwise specified.

The development of the drying shrinkage strain in time is strongly depends on  $\beta_{ds}(t, t_s)$  factor. SOFiSTiK accounts not only for the age at start of drying  $t_s$  but also for the influence of the age of the prestressing  $t_0$ . Therefore, the calculation of factor  $\beta_{ds}$  reads:

$$\beta_{ds} = \beta_{ds}(t, t_s) - \beta_{ds}(t_0, t_s)$$

3.1.4 (6): Eq. 3.10:  $\beta_{ds}$ 

$$\beta_{ds} = \frac{(t - t_s)}{(t - t_s) + 0.04 \cdot \sqrt{h_0^3}} - \frac{(t_0 - t_s)}{(t_0 - t_s) + 0.04 \cdot \sqrt{h_0^3}}$$

3.1.4 (6):  $h_0$  the notional size (mm) of the cs  $h_0 = 2A_c/u = 500$  mm

$$\beta_{ds} = \frac{(100 - 3)}{(100 - 3) + 0.04 \cdot \sqrt{400^3}} - \frac{(7 - 3)}{(7 - 3) + 0.04 \cdot \sqrt{400^3}}$$

$$\beta_{ds} = 0.232 - 0.01235 = 0.22026$$

$$k_h = 0.725 \text{ for } h_0 = 400 \text{ mm}$$

3.1.4 (6): Tab. 3.3:  $k_h$  coefficient depending on  $h_0$ 

$$\epsilon_{cd,0} = 0.85 \left[ (220 + 110 \cdot \alpha_{ds1}) \cdot \exp\left(-\alpha_{ds2} \cdot \frac{f_{cm}}{f_{cm0}}\right) \right] \cdot 10^{-6} \cdot \beta_{RH}$$

Annex B.2 (1): Eq. B.11:  $\epsilon_{cd,0}$  basic drying shrinkage strain

$$\beta_{RH} = 1.55 \left[ 1 - \left( \frac{RH}{RH_0} \right)^3 \right] = 1.55 \left[ 1 - \left( \frac{80}{100} \right)^3 \right] = 0.7564$$

Annex B.2 (1): Eq. B.12:  $\beta_{RH}$   
 $RH$  the ambient relative humidity (%)

$$\epsilon_{cd,0} = 0.85 \left[ (220 + 110 \cdot 4) \cdot \exp\left(-0.12 \cdot \frac{43}{10}\right) \right] \cdot 10^{-6} \cdot 0.7564$$

Annex B.2 (1):  $\alpha_{ds1}, \alpha_{ds2}$  coefficients depending on type of cement.  
For class N  $\alpha_{ds1} = 4, \alpha_{ds2} = 0.12$ 

$$\epsilon_{cd,0} = 2.533 \cdot 10^{-4}$$

$$\epsilon_{cd} = \beta_{ds} \cdot k_h \cdot \epsilon_{cd,0}$$

$$\epsilon_{cd} = 0.22026 \cdot 0.725 \cdot 2.533 \cdot 10^{-4} = -4.04 \cdot 10^{-5}$$

Drying shrinkage:

$$\epsilon_{cd} = -4.04 \cdot 10^{-5}$$

$$\epsilon_{ca}(t) = \beta_{as}(t) \cdot \epsilon_{ca}(\infty)$$

3.1.4 (6): Eq. 3.11:  $\epsilon_{ca}$  autogenous shrinkage strain

$$\epsilon_{ca}(\infty) = 2.5 (f_{ck} - 10) \cdot 10^{-6} = 2.5 \cdot (35 - 10) \cdot 10^{-6}$$

3.1.4 (6): Eq. 3.12:  $\epsilon_{ca}(\infty)$ 

$$\epsilon_{ca}(\infty) = 6.25 \cdot 10^{-5} = 0.0625 \text{ ‰}$$

Proportionally to  $\beta_{ds}(t, t_s)$ , SOFiSTiK calculates factor  $\beta_{as}$  as follows:

$$\beta_{as} = \beta_{as}(t) - \beta_{as}(t_0)$$

3.1.4 (6): Eq. 3.13:  $\beta_{as}$ 

$$\beta_{as} = 1 - e^{-0.2 \cdot \sqrt{t}} - \left( 1 - e^{-0.2 \cdot \sqrt{t_0}} \right) = e^{-0.2 \cdot \sqrt{t_0}} - e^{-0.2 \cdot \sqrt{t}}$$

$$\beta_{as} = 0.4537$$

$$\epsilon_{ca}(t) = \beta_{as}(t) \cdot \epsilon_{ca}(\infty)$$

$$\epsilon_{ca}(t) = 0.45377 \cdot 6.25 \cdot 10^{-5}$$

Autogenous shrinkage:

$$\epsilon_{ca}(t) = -2.84 \cdot 10^{-5}$$

Total shrinkage:

$$\epsilon_{CS} = \epsilon_{ca} + \epsilon_{cd}$$

$$\epsilon_{CS} = -2.84 \cdot 10^{-5} + (-4.04) \cdot 10^{-5} = -6.881 \cdot 10^{-5}$$

Calculating displacement:

$$\Delta l_{1,CS} = \epsilon_{CS} \cdot L/2$$

$$\Delta l_{1,CS} = -6.881 \cdot 10^{-5} \cdot 10000 \text{ mm}$$

$$\Delta l_{1,CS} = -0.6881 \text{ mm}$$

**2) Calculate displacement when loading occurs at time  $t_1 = 100$  days at  $x = 10.0 \text{ m}$  midspan**

$\epsilon$  absolute shrinkage strain  
negative sign to declare losses

$E_{CS}$  calculated "ideal" cross section modulus of elasticity for concrete and reinforcement steel

$$\sigma_c = E_{CS} \cdot \epsilon$$

$$E_{CS} = E_{cm} + \frac{A_s}{A_c} \cdot E_s$$

$$E_{CS} = 3407.7 + \frac{178.568}{16000 - 178.568} \cdot 20000$$

$$E_{CS} = 3407.7 + 225.729$$

$$E_{CS} = 3633.42 \text{ kN/cm}^2 = 36334.29 \text{ N/mm}^2$$

$$\epsilon = \frac{\sigma_c}{E_{CS}} = \frac{-0.5625}{36334.29} = -1.55 \cdot 10^{-5}$$

$$\epsilon = \frac{\Delta l_2}{l} \rightarrow \Delta l_2 = \epsilon \cdot L/2$$

$$\Delta l_2 = -1.55 \cdot 10^{-5} \cdot 10000 \text{ mm} = -0.155 \text{ mm}$$

**3) Calculating the displacement (creep and shrinkage) at time before the loading is inactive ( $t_2 \approx 300$  and  $t_2 < 300$  days)**

$t_0$  minimum age of concrete for loading  
 $t_s$  age of concrete at start of drying shrinkage  
 $t$  age of concrete at the moment considered

$$t_0 = 100 \text{ days}$$

$$t_s = 3 \text{ days}$$

$$t = 300 \text{ days}$$

$$t_{eff} = t - t_0 = 300 - 100 = 200 \text{ days}$$

• Calculating shrinkage:

$$\epsilon_{CS} = \epsilon_{cd} + \epsilon_{ca}$$

3.1.4 (6): Eq. 3.8:  $\epsilon_{CS}$  total shrinkage strain

3.1.4 (6): Eq. 3.9:  $\epsilon_{cd}$  drying shrinkage strain

$$\epsilon_{cd}(t) = \beta_{ds}(t, t_s) \cdot k_h \cdot \epsilon_{cd,0}$$

The development of the drying shrinkage strain in time is strongly depends on  $\beta_{ds}(t, t_s)$  factor. SOFiSTiK accounts not only for the age at start of drying  $t_s$  but also for the influence of the age of the prestressing

$t_0$ . Therefore, the calculation of factor  $\beta_{ds}$  reads:

$$\beta_{ds} = \beta_{ds}(t, t_s) - \beta_{ds}(t_0, t_s)$$

3.1.4 (6): Eq. 3.10:  $\beta_{ds}$

$$\beta_{ds} = \frac{(t - t_s)}{(t - t_s) + 0.04 \cdot \sqrt{h_0^3}} - \frac{(t_0 - t_s)}{(t_0 - t_s) + 0.04 \cdot \sqrt{h_0^3}}$$

3.1.4 (6):  $h_0$  the notional size (mm) of the cs  $h_0 = 2A_c/u = 500$  mm

$$\beta_{ds} = \frac{(300 - 3)}{(300 - 3) + 0.04 \cdot \sqrt{400^3}} - \frac{(100 - 3)}{(100 - 3) + 0.04 \cdot \sqrt{400^3}}$$

$$\beta_{ds} = 0.2487$$

$$k_h = 0.725 \text{ for } h_0 = 400 \text{ mm}$$

3.1.4 (6): Tab. 3.3:  $k_h$  coefficient depending on  $h_0$

$$\epsilon_{cd,0} = 0.85 \left[ (220 + 110 \cdot \alpha_{ds1}) \cdot \exp\left(-\alpha_{ds2} \cdot \frac{f_{cm}}{f_{cm0}}\right) \right] \cdot 10^{-6} \cdot \beta_{RH}$$

Annex B.2 (1): Eq. B.11:  $\epsilon_{cd,0}$  basic drying shrinkage strain

$$\beta_{RH} = 1.55 \left[ 1 - \left( \frac{RH}{RH_0} \right)^3 \right] = 1.55 \left[ 1 - \left( \frac{80}{100} \right)^3 \right] = 0.7564$$

Annex B.2 (1): Eq. B.12:  $\beta_{RH}$   
 $RH$  the ambient relative humidity (%)

$$\epsilon_{cd,0} = 0.85 \left[ (220 + 110 \cdot 4) \cdot \exp\left(-0.12 \cdot \frac{43}{10}\right) \right] \cdot 10^{-6} \cdot 0.7564$$

Annex B.2 (1):  $\alpha_{ds1}, \alpha_{ds2}$  coefficients depending on type of cement.

$$\epsilon_{cd,0} = 2.533 \cdot 10^{-4}$$

For class N  $\alpha_{ds1} = 4, \alpha_{ds2} = 0.12$

$$\epsilon_{cd} = 0.24874 \cdot 0.725 \cdot 2.533 \cdot 10^{-4} = -4.57 \cdot 10^{-5}$$

Drying shrinkage:

$$\epsilon_{cd} = -4.57 \cdot 10^{-5}$$

$$\epsilon_{ca}(t) = \beta_{as}(t) \cdot \epsilon_{ca}(\infty)$$

3.1.4 (6): Eq. 3.11:  $\epsilon_{ca}$  autogenous shrinkage strain

$$\epsilon_{ca}(\infty) = 2.5 \cdot (f_{ck} - 10) \cdot 10^{-6} = 2.5 (35 - 10) \cdot 10^{-6}$$

3.1.4 (6): Eq. 3.12:  $\epsilon_{ca}(\infty)$

$$\epsilon_{ca}(\infty) = 6.25 \cdot 10^{-5} = 0.0625 \text{ ‰}$$

Proportionally to  $\beta_{ds}(t, t_s)$ , SOFiSTiK calculates factor  $\beta_{as}$  as follows:

$$\beta_{as} = \beta_{as}(t) - \beta_{as}(t_0)$$

3.1.4 (6): Eq. 3.13:  $\beta_{as}$

$$\beta_{as} = 1 - e^{-0.2 \cdot \sqrt{t}} - \left( 1 - e^{-0.2 \cdot \sqrt{t_0}} \right) = e^{-0.2 \cdot \sqrt{t_0}} - e^{-0.2 \cdot \sqrt{t}}$$

$$\beta_{as} = 0.104$$

$$\epsilon_{ca}(t) = \beta_{as}(t) \cdot \epsilon_{ca}(\infty)$$

$$\epsilon_{ca}(t) = 0.1040 \cdot 6.25 \cdot 10^{-5}$$

Autogenous shrinkage:

$$\epsilon_{ca}(t) = -6.502136 \cdot 10^{-6}$$

Total shrinkage:

$$\epsilon_{CS} = \epsilon_{Ca} + \epsilon_{cd}$$

$$\epsilon_{CS} = -6.502136 \cdot 10^{-6} + (-4.57) \cdot 10^{-5}$$

$$\epsilon_{CS} = -5.218 \cdot 10^{-5}$$

$\epsilon$  absolute shrinkage strain  
negative sign to declare losses

Calculating displacement:

$$\Delta l_{3,CS} = \epsilon_{CS} \cdot L/2$$

$$\Delta l_{3,CS} = -5.218 \cdot 10^{-5} \cdot 10000 \text{ mm}$$

$$\Delta l_{3,CS} = -0.5218 \text{ mm}$$

• Calculating creep:

Annex B.1 (1): Eq. B.1:  $\phi(t, t_0)$  creep coefficient

$$\phi(t, t_0) = \phi_0 \cdot \beta_c(t, t_0)$$

Annex B.1 (1): Eq. B.2:  $\phi_0$  notional creep coefficient

$$\phi_0 = \phi_{RH} \cdot \beta(f_{cm}) \cdot \beta(t_0)$$

Annex B.1 (1): Eq. B.3:  $\phi_{RH}$  factor for effect of relative humidity on creep

$$\phi_{RH} = \left[ 1 + \frac{1 - RH/100}{0.1 \cdot \sqrt[3]{h_0}} \cdot \alpha_1 \right] \cdot \alpha_2$$

Annex B.1 (1): Eq. B.4:  $\beta(f_{cm})$  factor for effect of concrete strength on creep

$$\beta(f_{cm}) = \frac{16.8}{\sqrt{f_{cm}}} = 16.8 / \sqrt{43} = 2.562$$

Annex B.1 (1): Eq. B.8c:  $\alpha_1, \alpha_2, \alpha_3$  coefficients to consider influence of concrete strength

$$\alpha_1 = \left[ \frac{35}{f_{cm}} \right]^{0.7} = 0.8658 \leq 1$$

$$\alpha_2 = \left[ \frac{35}{f_{cm}} \right]^{0.2} = 0.9597 \leq 1$$

$$\alpha_3 = \left[ \frac{35}{f_{cm}} \right]^{0.5} = 0.9022 \leq 1$$

$$\phi_{RH} = \left[ 1 + \frac{1 - 80/100}{0.1 \cdot \sqrt[3]{400}} \cdot 0.8658 \right] \cdot 0.9597 = 1.1852$$

Annex B.1 (1): Eq. B.5:  $\beta(t_0)$  factor for effect of concrete age at loading on creep

$$\beta(t_0) = \frac{1}{(0.1 + t_0^{0.20})}$$

Annex B.1 (2): Eq. B.9:  $t_{0,T}$  temperature adjusted age of concrete at loading adjusted according to expression B.10

$$t_0 = t_{0,T} \cdot \left( \frac{9}{2 + t_{0,T}^{1.2}} + 1 \right)^\alpha \geq 0.5$$

Annex B.1 (3): Eq. B.10:  $t_T$  temperature adjusted concrete age which replaces  $t$  in the corresponding equations

$$t_T = \sum_{i=1}^n e^{-(4000/[273+T(\Delta t_i)]-13.65)} \cdot \Delta t_i$$

$$t_{0,T} = 100 \cdot e^{-(4000/[273+20]-13.65)} = 100 \cdot 1.0 = 100.0$$

Annex B.1 (2): Eq. B.9:  $\alpha$  a power which depends on type of cement  
For class N  $\alpha = 0$

$$\Rightarrow t_0 = 100 \cdot \left( \frac{9}{2 + 100^{1.2}} + 1 \right)^0 = 100$$

$$\beta(t_0) = \frac{1}{(0.1 + 100^{0.20})} = 0.383$$

The coefficient to describe the development of creep with time after

loading can be calculated according to EN 1992-1-1, Eq. B.7.:

$$\beta_c(t, t_0) = \left[ \frac{(t - t_0)}{(\beta_H + t - t_0)} \right]^{0.3}$$

Annex B.1 (1): Eq. B.7:  $\beta_c(t, t_0)$  coefficient to describe the development of creep with time after loading

In SOFiSTiK it is possible to modify and use custom creep and shrinkage parameters, for more details see AQUA and AQB Manual. In our case we are using the equation from fib Model Code 2010[16] (to verify and show the MEXT feature in SOFiSTiK):

$$\beta_c(t, t_0) = \left[ \frac{(t - t_0)}{(\beta_H + t - t_0)} \right]^{\gamma(t_0)}$$

fib Model Code 2010; Eq. 5.1-71a

where:

$$\gamma(t_0) = \frac{1}{2.3 + \frac{3.5}{\sqrt{t_0}}} = \frac{1}{2.3 + \frac{3.5}{\sqrt{100}}} = \frac{1}{2.65} = 0.3773$$

fib Model Code 2010; Eq. 5.1-71b

With MEXT NO 1 EIGE VAL 0.3773 the exponent 0.3 can be modified to 0.3773.

$$\beta_c(t, t_0) = \left[ \frac{(t - t_0)}{(\beta_H + t - t_0)} \right]^{0.3773}$$

Annex B.1 (1): Eq. B.7:  $\beta_c(t, t_0)$  coefficient to describe the development of creep with time after loading

$$\beta_H = 1.5 \cdot [1 + (0.012 \cdot RH)^{18}] \cdot h_0 + 250 \cdot \alpha_3 \leq 1500 \cdot \alpha_3$$

Annex B.1 (1): Eq. B.8:  $\beta_H$  coefficient depending on relative humidity and notional member size

$$\beta_H = 1.5 \cdot [1 + (0.012 \cdot 80)^{18}] \cdot 400 + 250 \cdot 0.9022$$

$$\beta_H = 1113.31 \leq 1500 \cdot 0.9022 = 1353.30$$

$$\Rightarrow \beta_c(t, t_0) = 0.4916$$

$$\phi_0 = \phi_{RH} \cdot \beta(f_{cm}) \cdot \beta(t_0)$$

$$\phi_0 = 1.1852 \cdot 2.5619 \cdot 0.383 = 1.1629$$

$$\phi(t, t_0) = \phi_0 \cdot \beta_c(t, t_0)$$

$$\phi(t, t_0) = 1.1629 \cdot 0.4916 = 0.57$$

$$\phi_{eff}(t, t_0) = 0.57/1.05 = 0.5445$$

Annex B.1 (3): The values of  $\phi(t, t_0)$  given above should be associated with the tangent modulus  $E_c$

According to EN, the creep value is related to the tangent Young's modulus  $E_c$ , where  $E_c$  being defined as  $1.05 \cdot E_{cm}$ . To account for this, SOFiSTiK adopts this scaling for the computed creep coefficient (in SOFiSTiK, all computations are consistently based on  $E_{cm}$ ).

3.1.4 (2): The values of the creep coefficient,  $\phi(t, t_0)$  is related to  $E_c$ , the tangent modulus, which may be taken as  $1.05 \cdot E_{cm}$

Calculating the displacement:

$$\epsilon_{cc}(t, t_0) = \phi(t, t_0) \cdot \frac{\sigma_c}{E_{cs}}$$

$$\epsilon_{cc}(t, t_0) = 0.57 \cdot \frac{-0.5625}{36334.29} = -8.82430 \cdot 10^{-6}$$

$$\epsilon = \frac{\Delta l}{l} \rightarrow \Delta l_{3,cc} = \epsilon_{cc} \cdot L/2$$

$$\Delta l_{3,CC} = -8.82430 \cdot 10^{-6} \cdot 10000 \text{ mm} = -0.08824 \text{ mm}$$

**4) Calculating the displacement at time when the loading is inactive ( $t_2 \approx 300$  and  $t_2 > 300$  days).**

At this step the loading disappears therefore:

$$\Delta l_4 = -\Delta l_2 = 0.155 \text{ mm}$$

**5) Calculating the displacement at time  $t_3 = 30$  years.**

$t_0$  minimum age of concrete for loading  
 $t_s$  age of concrete at start of drying shrinkage  
 $t$  age of concrete at the moment considered

$$t_0 = 300 \text{ days}$$

$$t_s = 3 \text{ days}$$

$$t = 11250 \text{ days}$$

$$t_{eff} = t - t_0 = 11250 - 300 = 11950 \text{ days}$$

$$\rightarrow 11950/365 = 30 \text{ years}$$

• Calculating shrinkage:

3.1.4 (6): Eq. 3.8:  $\epsilon_{CS}$  total shrinkage strain

$$\epsilon_{CS} = \epsilon_{cd} + \epsilon_{ca}$$

3.1.4 (6): Eq. 3.9:  $\epsilon_{cd}$  drying shrinkage strain

$$\epsilon_{cd}(t) = \beta_{ds}(t, t_s) \cdot k_h \cdot \epsilon_{cd,0}$$

The development of the drying shrinkage strain in time is strongly depends on  $\beta_{ds}(t, t_s)$  factor. SOFiSTiK accounts not only for the age at start of drying  $t_s$  but also for the influence of the age of the prestressing  $t_0$ . Therefore, the calculation of factor  $\beta_{ds}$  reads:

3.1.4 (6): Eq. 3.10:  $\beta_{ds}$

$$\beta_{ds} = \beta_{ds}(t, t_s) - \beta_{ds}(t_0, t_s)$$

3.1.4 (6):  $h_0$  the notional size (mm) of the cs  $h_0 = 2A_c/u = 500 \text{ mm}$

$$\beta_{ds} = \frac{(t - t_s)}{(t - t_s) + 0.04 \cdot \sqrt{h_0^3}} - \frac{(t_0 - t_s)}{(t_0 - t_s) + 0.04 \cdot \sqrt{h_0^3}}$$

$$\beta_{ds} = \frac{(11250 - 3)}{(11250 - 3) + 0.04 \cdot \sqrt{400^3}} - \frac{(300 - 3)}{(300 - 3) + 0.04 \cdot \sqrt{400^3}}$$

$$\beta_{ds} = 0.49097$$

3.1.4 (6): Tab. 3.3:  $k_h$  coefficient depending on  $h_0$

$$k_h = 0.725 \text{ for } h_0 = 400 \text{ mm}$$

Annex B.2 (1): Eq. B.11:  $\epsilon_{cd,0}$  basic drying shrinkage strain

$$\epsilon_{cd,0} = 0.85 \left[ (220 + 110 \cdot \alpha_{ds1}) \cdot \exp\left(-\alpha_{ds2} \cdot \frac{f_{cm}}{f_{cm0}}\right) \right] \cdot 10^{-6} \cdot \beta_{RH}$$

Annex B.2 (1): Eq. B.12:  $\beta_{RH}$   
 $RH$  the ambient relative humidity (%)

$$\beta_{RH} = 1.55 \left[ 1 - \left( \frac{RH}{RH_0} \right)^3 \right] = 1.55 \left[ 1 - \left( \frac{80}{100} \right)^3 \right] = 0.7564$$

Annex B.2 (1):  $\alpha_{ds1}, \alpha_{ds2}$  coefficients depending on type of cement.

For class N  $\alpha_{ds1} = 4, \alpha_{ds2} = 0.12$

$$\epsilon_{cd,0} = 0.85 \left[ (220 + 110 \cdot 4) \cdot \exp\left(-0.12 \cdot \frac{43}{10}\right) \right] \cdot 10^{-6} \cdot 0.7564$$

$$\epsilon_{cd,0} = 2.533 \cdot 10^{-4}$$

$$\epsilon_{cd} = \beta_{ds}(t, t_s) \cdot k_h \cdot \epsilon_{cd,0}$$



$$\epsilon_{cd} = 0.49097 \cdot 0.725 \cdot 2.533 \cdot 10^{-4} = -9.02 \cdot 10^{-5}$$

Drying shrinkage:

$$\epsilon_{cd} = -9.02 \cdot 10^{-5}$$

$$\epsilon_{ca}(t) = \beta_{as}(t) \cdot \epsilon_{ca}(\infty)$$

3.1.4 (6): Eq. 3.11:  $\epsilon_{ca}$  autogenous shrinkage strain

$$\epsilon_{ca}(\infty) = 2.5 \cdot (f_{ck} - 10) \cdot 10^{-6} = 2.5 (35 - 10) \cdot 10^{-6}$$

3.1.4 (6): Eq. 3.12:  $\epsilon_{ca}(\infty)$

$$\epsilon_{ca}(\infty) = 6.25 \cdot 10^{-5} = 0.0625 \text{ ‰}$$

Proportionally to  $\beta_{ds}(t, t_s)$ , SOFiSTiK calculates factor  $\beta_{as}$  as follows:

$$\beta_{as} = \beta_{as}(t) - \beta_{as}(t_0)$$

3.1.4 (6): Eq. 3.13:  $\beta_{as}$

$$\beta_{as} = 1 - e^{-0.2 \cdot \sqrt{t}} - \left(1 - e^{-0.2 \cdot \sqrt{t_0}}\right) = e^{-0.2 \cdot \sqrt{t_0}} - e^{-0.2 \cdot \sqrt{t}}$$

$$\beta_{as} = 0.03130$$

$$\epsilon_{ca}(t) = \beta_{as}(t) \cdot \epsilon_{ca}(\infty)$$

$$\epsilon_{ca}(t) = 0.03130 \cdot 6.25 \cdot 10^{-5}$$

Autogenous shrinkage:

$$\epsilon_{ca}(t) = -1.95632 \cdot 10^{-6}$$

Total shrinkage:

$$\epsilon_{cs} = \epsilon_{ca} + \epsilon_{cd}$$

$$\epsilon_{cs} = -1.95632 \cdot 10^{-6} + (-9.02) \cdot 10^{-5}$$

$$\epsilon_{cs} = -9.212 \cdot 10^{-5}$$

$\epsilon$  absolute shrinkage strain  
negative sign to declare losses

Calculating displacement:

$$\Delta l_{5,cs} = \epsilon_{cs} \cdot L/2$$

$$\Delta l_{5,cs} = -9.212 \cdot 10^{-5} \cdot 10000 \text{ mm}$$

$$\Delta l_{5,cs} = -0.9212 \text{ mm}$$

• Calculating creep:

$$\phi(t, t_0) = \phi_0 \cdot \beta_c(t, t_0)$$

Annex B.1 (1): Eq. B.1:  $\phi(t, t_0)$  creep coefficient

$$\phi_0 = \phi_{RH} \cdot \beta(f_{cm}) \cdot \beta(t_0)$$

Annex B.1 (1): Eq. B.2:  $\phi_0$  notional creep coefficient

$$\phi_{RH} = \left[ 1 + \frac{1 - RH/100}{0.1 \cdot \sqrt[3]{h_0}} \cdot \alpha_1 \right] \cdot \alpha_2$$

Annex B.1 (1): Eq. B.3:  $\phi_{RH}$  factor for effect of relative humidity on creep

Annex B.1 (1): Eq. B.4:  $\beta(f_{cm})$  factor for effect of concrete strength on creep

$$\beta(f_{cm}) = \frac{16.8}{\sqrt{f_{cm}}} = 16.8/\sqrt{43} = 2.562$$

Annex B.1 (1): Eq. B.8c:  $\alpha_1, \alpha_2, \alpha_3$  coefficients to consider influence of concrete strength

$$\alpha_1 = \left[ \frac{35}{f_{cm}} \right]^{0.7} = 0.8658 \leq 1$$

$$\alpha_2 = \left[ \frac{35}{f_{cm}} \right]^{0.2} = 0.9597 \leq 1$$

$$\alpha_3 = \left[ \frac{35}{f_{cm}} \right]^{0.5} = 0.9022 \leq 1$$

$$\phi_{RH} = \left[ 1 + \frac{1 - 80/100}{0.1 \cdot \sqrt[3]{400}} \cdot 0.8658 \right] \cdot 0.9597 = 1.1852$$

Annex B.1 (1): Eq. B.5:  $\beta(t_0)$  factor for effect of concrete age at loading on creep

$$\beta(t_0) = \frac{1}{(0.1 + t_0^{0.20})}$$

Annex B.1 (2): Eq. B.9:  $t_{0,T}$  temperature adjusted age of concrete at loading adjusted according to expression B.10

$$t_0 = t_{0,T} \cdot \left( \frac{9}{2 + t_{0,T}^{1.2}} + 1 \right)^\alpha \geq 0.5$$

Annex B.1 (3): Eq. B.10:  $t_T$  temperature adjusted concrete age which replaces  $t$  in the corresponding equations

$$t_T = \sum_{i=1}^n e^{-(4000/[273+T(\Delta t_i)]-13.65)} \cdot \Delta t_i$$

$$t_{0,T} = 300 \cdot e^{-(4000/[273+20]-13.65)} = 300 \cdot 1.0 = 300.0$$

Annex B.1 (2): Eq. B.9:  $\alpha$  a power which depends on type of cement  
For class N  $\alpha = 0$

$$\Rightarrow t_0 = 300 \cdot \left( \frac{9}{2 + 300^{1.2}} + 1 \right)^0 = 300$$

$$\beta(t_0) = \frac{1}{(0.1 + 300^{0.20})} = 0.3097$$

The coefficient to describe the development of creep with time after loading can be calculated according to EN 1992-1-1, Eq. B.7.:

Annex B.1 (1): Eq. B.7:  $\beta_c(t, t_0)$  coefficient to describe the development of creep with time after loading

$$\beta_c(t, t_0) = \left[ \frac{(t - t_0)}{(\beta_H + t - t_0)} \right]^{0.3}$$

In SOFiSTiK it is possible to modify and use custom creep and shrinkage parameters, for more details see AQUA and AQB Manual. In our case we are using the equation from fib Model Code 2010[16] (to verify and show the MEXT feature in SOFiSTiK).

With MEXT NO 1 EIGE VAL 0.3773 the exponent 0.3 can be modified to 0.3773.

Annex B.1 (1): Eq. B.7:  $\beta_c(t, t_0)$  coefficient to describe the development of creep with time after loading

$$\beta_c(t, t_0) = \left[ \frac{(t - t_0)}{(\beta_H + t - t_0)} \right]^{0.3773}$$

Annex B.1 (1): Eq. B.8:  $\beta_H$  coefficient depending on relative humidity and notional member size

$$\beta_H = 1.5 \cdot [1 + (0.012 \cdot RH)^{18}] \cdot h_0 + 250 \cdot \alpha_3 \leq 1500 \cdot \alpha_3$$

$$\beta_H = 1.5 \cdot [1 + (0.012 \cdot 80)^{18}] \cdot 400 + 250 \cdot 0.9022$$

$$\beta_H = 1113.31 \leq 1500 \cdot 0.9022 = 1353.30$$

$$\Rightarrow \beta_c(t, t_0) = 0.9641$$

$$\phi_0 = \phi_{RH} \cdot \beta(f_{cm}) \cdot \beta(t_0)$$

$$\phi_0 = 1.1852 \cdot 2.5619 \cdot 0.3097 = 0.94067$$

$$\phi(t, t_0) = \phi_0 \cdot \beta_c(t, t_0)$$

$$\phi(t, t_0) = 0.94067 \cdot 0.9641 = 0.91$$

$$\phi_{eff}(t, t_0) = 0.91/1.05 = 0.8637$$

According to EN, the creep value is related to the tangent Young's modulus  $E_c$ , where  $E_c$  being defined as  $1.05 \cdot E_{cm}$ . To account for this, SOFiSTiK adopts this scaling for the computed creep coefficient (in SOFiSTiK, all computations are consistently based on  $E_{cm}$ ).

Annex B.1 (3): The values of  $\phi(t, t_0)$  given above should be associated with the tangent modulus  $E_c$

3.1.4 (2): The values of the creep coefficient,  $\phi(t, t_0)$  is related to  $E_c$ , the tangent modulus, which may be taken as  $1.05 \cdot E_{cm}$

$$\epsilon_{cc}(t, t_0) = \phi(t, t_0) \cdot \frac{\sigma_c}{E_{cs}}$$

$$\epsilon_{cc}(t, t_0) = 0.91 \cdot \frac{-0.5625}{36334.29} = -1.4087 \cdot 10^{-5}$$

$$\epsilon = \frac{\Delta l}{l} \rightarrow \Delta l_{5,cc} = \epsilon_{cc} \cdot L/2$$

$$\Delta l_{5,cc} = -1.4087 \cdot 10^{-5} \cdot 10000 \text{ mm} = -0.1408 \text{ mm}$$

CALCULATING THE DISPLACEMENT:

**- 4010 stripping concrete**

$$\Delta l_{4010} = 0 \text{ mm}$$

**- 4015 K creep step**

$$\Delta l_{4015} = \Delta l_{1,cs}$$

$$\Delta l_{4015} = -0.688 \text{ mm}$$

**- 4020 Start loading A**

$$\Delta l_{4020} = \Delta l_{1,cs} + \Delta l_2$$

$$\Delta l_{4020} = -0.6881 - 0.155$$

$$\Delta l_{4020} = -0.8431 \text{ mm}$$

**- 4025 K creep step**

$$\Delta l_{4025} = \Delta l_{1,cs} + \Delta l_2 + \Delta l_{3,cs} + \Delta l_{3,cc}$$

$$\Delta l_{4025} = -0.6881 - 0.155 - 0.08824 - 0.5218$$

$$\Delta l_{4025} = -1.45314 \text{ mm}$$

**- 4030 Stop loading A**

$$\Delta l_{4030} = \Delta l_{1,cs} + \Delta l_2 + \Delta l_{3,cs} + \Delta l_{3,cc} - \Delta l_4$$

$$\Delta l_{4030} = -0.6881 - 0.155 - 0.08824 - 0.5218 + 0.155$$

$$\Delta l_{4030} = -1.29814 \text{ mm}$$

**- 4035 K creep step**

$$\Delta l_{4035} = \Delta l_{4030} + \Delta l_{5,cs} - \Delta l_{5,cc}$$

$$\Delta l_{4035} = -1.29814 - 0.9212 + 0.140$$

$$\Delta l_{4035} \approx -2.08 \text{ mm}$$

## 23.5 Conclusion

This example shows the calculation of the time dependent displacements due to creep and shrinkage. It has been shown that the results are in very good agreement with the reference solution.

## 23.6 Literature

- [2] F. Fingerloos, J. Hegger, and K. Zilch. *DIN EN 1992-1-1 Bemessung und Konstruktion von Stahlbeton- und Spannbetontragwerken - Teil 1-1: Allgemeine Bemessungsregeln und Regeln für den Hochbau*. BVPI, DBV, ISB, VBI. Ernst & Sohn, Beuth, 2012.
  - [6] *EN 1992-1-1: Eurocode 2: Design of concrete structures, Part 1-1: General rules and rules for buildings*. CEN. 2004.
  - [16] fib Model Code 2010. *fib Model Code for Concrete Structures 2010*. International Federation for Structural Concrete (fib). 2010.
-



## 24 DCE-EN22: Stress Relaxation of Prestressing Steel - EN 1992-1-1

### Overview

<b>Design Code Family(s):</b>	EN
<b>Design Code(s):</b>	EN 1992-1-1
<b>Module(s):</b>	AQB, AQUA
<b>Input file(s):</b>	<a href="#">relaxation_en1992.dat</a>

### 24.1 Problem Description

The problem consists of a simply supported beam with a rectangular cross-section of prestressed concrete, as shown in Fig. 24.1. The time dependent losses are calculated, considering the reduction of stress caused by the deformation of prestressing steel due to steel-relaxation, under the permanent loads.

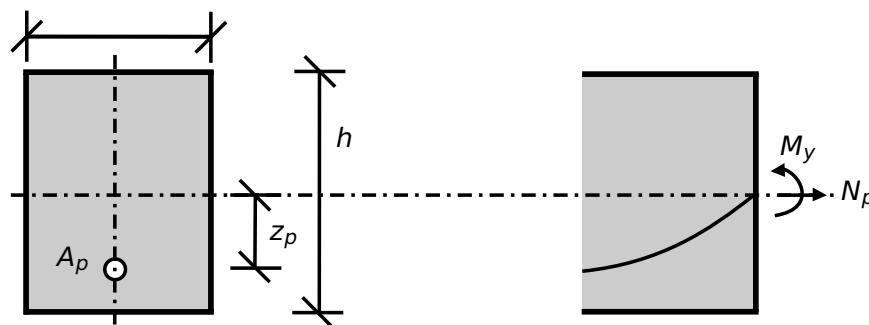

Figure 24.1: Problem Description

### 24.2 Reference Solution

This example is concerned with the calculation of relaxation losses on a prestressed concrete cs, subject to bending and prestress force. The content of this problem is covered by the following parts of EN 1992-1-1:2004 [6]:

- Properties (Section 3.3.2)
- Annex D: Detailed calculation method for prestressing steel relaxation losses (Section D.1)
- Strength (Section 3.3.3)

In this Benchmark the stress loss due to relaxation will be examined, creep and shrinkage losses are neglected and disabled.

### 24.3 Model and Results

Benchmark 17 is here extended for the case of steel relaxation losses developing on a prestressed concrete simply supported beam. The analysed system can be seen in Fig. 24.2, with properties as defined in Table 24.1. Further information about the tendon geometry and prestressing can be found in benchmark 17. The beam consists of a rectangular cs and is prestressed and loaded with its own

weight. A calculation of the relaxation stress losses is performed in the middle of the span with respect to EN 1992-1-1:2004 [6]. The calculation steps are presented below and the results are given in Table 24.2 for the calculation with AQB.

Table 24.1: Model Properties

Material Properties	Geometric Properties	Loading (at $x = 10\text{ m}$ )	Time
C 35/45	$h = 100.0\text{ cm}$	$M_g = 1250\text{ kNm}$	$t = 1000\text{ h}$
Y 1770	$b = 100.0\text{ cm}$	$N_p = -3653.0\text{ kN}$	
$RH = 80$	$L = 20.0\text{ m}$		
	$A_p = 28.5\text{ cm}^2$		

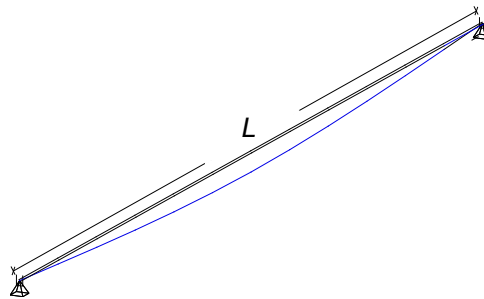

Figure 24.2: Simply Supported Beam

Table 24.2: Results

Result	AQB	Ref.
$\Delta\sigma_{pr,total}$	14.38 MPa	14.38 MPa
$\Delta P_{pr}$	40.95 kN	40.95 kN
$\frac{\Delta P_{pr}}{P_0} [\%]$	1.12%	1.12%



## 24.4 Design Process<sup>1</sup>

### Design with respect to EN 1992-1-1:2004 [6]

- Material:

Concrete: C 35/45

$$E_{cm} = 34077 \text{ N/mm}^2$$

$$f_{ck} = 35 \text{ N/mm}^2$$

$$f_{cm} = 43 \text{ N/mm}^2$$

Prestressing Steel: Y 1770

$$E_p = 195000 \text{ N/mm}^2$$

$$f_{pk} = 1770 \text{ N/mm}^2$$

$$f_{p0,1k} = 1520 \text{ N/mm}^2$$

Prestressing system: *BBV L19 150 mm<sup>2</sup>*

19 wires with area of  $150 \text{ mm}^2$  each, giving a total of  $A_p = 28.5 \text{ cm}^2$

- Cross-section:

$$A_c = 1.0 \cdot 1.0 = 1 \text{ m}^2$$

Diameter of duct  $\phi_{duct} = 97 \text{ mm}$

$$\text{Ratio } \alpha_{E,p} = E_p / E_{cm} = 195000 / 34077 = 5.7223$$

$$A_{c,netto} = A_c - \pi \cdot (\phi_{duct}/2)^2 = 0.9926 \text{ m}^2$$

$$A_{ideal} = A_c + A_p \cdot \alpha_{E,p} = 1.013 \text{ m}^2$$

- Prestressing forces and stresses

The force applied to a tendon, i.e. the force at the active end during tensioning, should not exceed the following value

$$P_{max} = A_p \cdot \sigma_{p,max}$$

$$\text{where } \sigma_{p,max} = \min(0.8 \cdot f_{pk}; 0.90 \cdot f_{p0,1k})$$

$$P_{max} = A_p \cdot 0.80 \cdot f_{pk} = 28.5 \cdot 10^{-4} \cdot 0.80 \cdot 1770 = 4035.6 \text{ kN}$$

$$P_{max} = A_p \cdot 0.90 \cdot f_{p0,1k} = 28.5 \cdot 10^{-4} \cdot 0.90 \cdot 1520 = 3898.8 \text{ kN}$$

$$\rightarrow P_{max} = 3898.8 \text{ kN and } \sigma_{p,max} = 1368 \text{ N/mm}^2$$

The value of the initial prestress force at time  $t = t_0$  applied to the concrete immediately after tensioning and anchoring should not exceed the following value

3.1: Concrete

3.1.2: Tab. 3.1:  $E_{cm}$ ,  $f_{ck}$  and  $f_{cm}$  for C 35/45

3.3: Prestressing Steel

3.3.6 (3):  $E_p$  for wires

3.3.2, 3.3.3:  $f_{pk}$  Characteristic tensile strength of prestressing steel

3.3.2, 3.3.3:  $f_{p0,1k}$  0.1% proof-stress of prestressing steel, yield strength

5.10.3 (2): Prestress force

<sup>1</sup>The tools used in the design process are based on steel stress-strain diagrams, as defined in [6] 3.3.6: Fig. 3.10

5.10.3 (2): Eq. 5.43:  $P_{m0}$  initial prestress force at time  $t = t_0$

(NDP) 5.10.3 (2):  $\sigma_{p,m0}(x)$  stress in the tendon immediately after tensioning or transfer

$$P_{m0}(x) = A_p \cdot \sigma_{p,m0}(x)$$

$$\text{where } \sigma_{p,m0}(x) = \min \{0.75f_{pk}; 0.85f_{p0,1k}\}$$

$$P_{m0} = A_p \cdot 0.75 \cdot f_{pk} = 28.5 \cdot 10^{-4} \cdot 0.75 \cdot 1770 = 3783.4 \text{ kN}$$

$$P_{m0} = A_p \cdot 0.85 \cdot f_{p0,1k} = 28.5 \cdot 10^{-4} \cdot 0.85 \cdot 1520 = 3682.2 \text{ kN}$$

$$\rightarrow P_{m0} = 3682.2 \text{ kN and } \sigma_{p,m0} = 1292 \text{ N/mm}^2$$

Further calculations for the distribution of prestress forces and stresses along the beam are not in the scope of this benchmark and will not be described here. The complete diagram can be seen in benchmark 17, after the consideration of losses at anchorage and due to friction, as calculated by SOFiSTiK. There the values of  $\sigma_{p,max} = 1368 \text{ N/mm}^2$  and  $P_{m0} = 3682.2 \text{ kN}$  can be visualised.

In this benchmark the beam number 10010 is analysed therefore the prestressing force is obtained from TENDON:

$$P_0 = 3653 \text{ kN}$$

$$\sigma_{p,0} = 1281.755 \text{ MPa}$$

#### Calculating the prestressing losses due relaxation

According to EN 1992-1-1, 3.3.2 (5), the value of  $\rho_{1000}$  is expressed as a percentage ratio of the initial stress and is obtained for an initial stress equal to  $0.7 \cdot f_p$ , where  $f_p$  is the actual tensile strength of the prestressing steel samples. For design calculations, the characteristic tensile strength ( $f_{pk}$ ) is used.

$$\mu = \frac{\sigma_{p0}}{f_{pk}} = \frac{1281.755}{1770} = 0.724155 \geq \mu_{min} = 0.55$$

The relaxation loss may be obtained from the manufactures test certificates or defined as percentage ratio of the variation of the prestressing stress over the initial prestressing stress, should be determined by applying next expression:

EC2-1-1, 3.3.2 (7): Eq. 3.29

$$\frac{\Delta\sigma_{pr}}{\sigma_{pi}} = 0.66 \cdot \rho_{1000} \cdot e^{9.1 \cdot \mu} \cdot \left(\frac{t}{1000}\right)^{0.75 \cdot (1-\mu)} \cdot 10^{-5}$$

$$t = 1000 \text{ h} \rightarrow \left(\frac{t}{1000}\right)^{0.75 \cdot (1-\mu)} = 1.00$$

EC2-1-1, 3.3.2 (6)

The values for  $\rho_{1000}$  can be either assumed equal to 8% for Class 1, **2.5% for Class 2**, and 4% for Class 3, or taken from the certificate.

For prestressing steel Y 1570/1770  $\rightarrow \rho_{1000} = 2.5 \%$

The relaxation is checked for  $\mu = 0.7$  and for  $\mu = 0.72415$

$$\frac{\Delta\sigma_{pr}}{\sigma_{pi}} = 0.66 \cdot \rho_{1000} \cdot e^{9.1 \cdot 0.70} \cdot 10^{-5} \cdot 100 = 0.963695 \%$$

$$\frac{\Delta\sigma_{pr}}{\sigma_{pi}} = 0.66 \cdot \rho_{1000} \cdot e^{9.1 \cdot 0.724155} \cdot 10^{-5} \cdot 100 = 1.200616 \%$$

$$\Delta\sigma_{pr} = \sigma_{pi} \cdot 1.200616 \%$$

$$\Delta\sigma_{pr} = 1281.755 \cdot 1.200616 \% = 15.388 \text{ MPa}$$

AQB reduces the initial stress according to DIN 1045-1:

DIN 1045-1 8.7.3 (6)

$$\Delta P_{c+s+r} = A_p \frac{\epsilon_{cs} \cdot E_p + \Delta\sigma_{pr} + \frac{E_p}{E_{cm}} \cdot \phi(t, t_0) \cdot \sigma_{c,QP}}{1 + \frac{E_p}{E_{cm}} \cdot \frac{A_p}{A_c} \left( 1 + \frac{A_c}{I_c} \cdot z_{cp}^2 \right) [1 + 0.8 \cdot \phi(t, t_0)]}$$

DIN 1045-1 8.7.3 (6):  $\Delta P_{c+s+r}$  time dependent losses of prestress

Creep and shrinkage is not taken into account therefore we have:

$$\epsilon_{cs} \cdot E_p = 0$$

$$\frac{E_p}{E_{cm}} \cdot \phi(t, t_0) \cdot \sigma_{c,QP} = 0$$

$$1 + 0.8 \cdot \phi(t, t_0) = 1$$

$$\Delta\sigma_{p,c+s+r} = \frac{15.388}{1 + \frac{195000}{34077} \cdot \frac{28.5 \cdot 10^{-4}}{0.9926} \cdot \left( 1 + \frac{0.9926}{0.08214} \cdot 0.3901^2 \right)}$$

$$\Delta\sigma_{p,c+s+r} = \frac{15.388}{1.046644} = 14.70 \text{ MPa}$$

Now we have:

$$\sigma_{p0} = \sigma_{pg0} - 0.3 \cdot \Delta\sigma_{p,c+s+r}$$

$$\sigma_{p0} = 1281.755 - 0.3 \cdot 14.70 = 1277.345 \text{ MPa}$$

DIN 1045-1 8.7.3 (6)

Now with the reduced stress the  $\mu$  value is calculated again (iteration):

$$\mu = \frac{\sigma_{p0}}{f_{pk}} = \frac{1277.345}{1770} = 0.72166 \geq \mu_{min} = 0.55$$

$$\frac{\Delta\sigma_{pr}}{\sigma_{pi}} = 0.66 \cdot \rho_{1000} \cdot e^{9.1 \cdot 0.72166} \cdot 10^{-5} \cdot 100 = 1.1736 \%$$

$$\Delta\sigma_{pr} = 1281.755 \cdot 1.1736\% = 15.043 \text{ MPa}$$

The total loss:

$$\Delta\sigma_{pr,total} = \Delta\sigma_{pr,t} + \Delta\sigma_{pr,c}$$

$$\Delta\sigma_{pr,t} = \Delta\sigma_{pr} = 15.043 \text{ MPa}$$

$$\Delta\sigma_{pr,c} = (\epsilon_{k0} + \epsilon_{ky} \cdot z_{cp} - \epsilon_{kz} \cdot y_{cp}) \cdot E_p$$

$\epsilon_{k0}$ ,  $\epsilon_{ky}$  and  $\epsilon_{kz}$  - tendon strain

$$\Delta\sigma_{pr,c} = (1.212 \cdot 10^{-6} + 5.673 \cdot 10^{-6} \cdot 0.39) \cdot 1.95 \cdot 10^8 / 1000$$

$$\Delta\sigma_{pr,c} = 0.667968 \text{ MPa}$$

$$\Delta\sigma_{pr,total} = 15.043 - 0.667968 = 14.37 \text{ MPa}$$

$$\Delta P_{pr} = \Delta\sigma_{pr,total} \cdot A_p = 14.37 \cdot 28.5 \cdot 10^{-4} = 40.9545 \text{ kN}$$

Prestress force loss in [%]:

$$\Delta P_{pr}[\%] = \frac{\Delta P_{pr}}{P_0}$$

$$\Delta P_{pr}[\%] = \frac{40.9545}{3653} = 0.01120 \cdot 100\% = 1.12 \%$$

## 24.5 Conclusion

This example shows the calculation of the time dependent losses due to relaxation. It has been shown that the reference solution and the AQB solution are in very good agreement.

## 24.6 Literature

- [6] *EN 1992-1-1: Eurocode 2: Design of concrete structures, Part 1-1: General rules and rules for buildings*. GEN. 2004.
-



## 25 DCE-EN23: Stress Relaxation of Prestressing Steel - DIN EN 1992-1-1

### Overview

<b>Design Code Family(s):</b>	DIN
<b>Design Code(s):</b>	DIN EN 1992-1-1
<b>Module(s):</b>	AQB, AQUA
<b>Input file(s):</b>	<a href="#">relaxation_din_en1992.dat</a>

### 25.1 Problem Description

The problem consists of a simply supported beam with a rectangular cross-section of prestressed concrete, as shown in Fig. 25.1. The time dependent losses are calculated, considering the reduction of stress caused by the deformation of prestressing steel due to steel-relaxation, under the permanent loads.

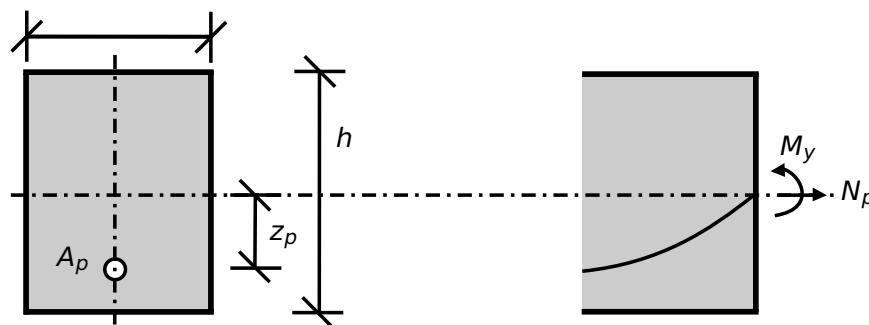

Figure 25.1: Problem Description

### 25.2 Reference Solution

This example is concerned with the calculation of relaxation losses on a prestressed concrete cs, subject to bending and prestress force. The content of this problem is covered by the following parts of DIN EN 1992-1-1:2004 [1] [2]:

- Properties (Section 3.3.2)
- Annex D: Detailed calculation method for prestressing steel relaxation losses (Section D.1)
- Strength (Section 3.3.3)
- DIN-HB, "Zulassung Spannstahl" [17]

In this Benchmark the stress loss due to relaxation will be examined, creep and shrinkage losses are neglected and disabled.

### 25.3 Model and Results

Benchmark 17 is here extended for the case of steel relaxation losses developing on a prestressed concrete simply supported beam. The analysed system can be seen in Fig. 25.2, with properties as

defined in Table 25.1. Further information about the tendon geometry and prestressing can be found in benchmark 17. The beam consists of a rectangular cs and is prestressed and loaded with its own weight. A calculation of the relaxation stress losses is performed in the middle of the span with respect to DIN EN 1992-1-1:2004 [1] [2]. The calculation steps are presented below and the results are given in Table 25.2 for the calculation with AQB.

Table 25.1: Model Properties

Material Properties	Geometric Properties	Loading (at $x = 10\text{ m}$ )	Time
C 35/45	$h = 100.0\text{ cm}$	$M_g = 1250\text{ kNm}$	$t = 1000\text{ h}$
Y 1770	$b = 100.0\text{ cm}$	$N_p = -3653.0\text{ kN}$	
$RH = 80$	$L = 20.0\text{ m}$		
	$A_p = 28.5\text{ cm}^2$		

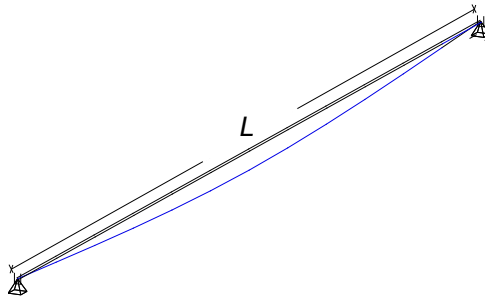

Figure 25.2: Simply Supported Beam

Table 25.2: Results

Result	AQB	Ref.
$\Delta\sigma_{pr,total}$	29.15 MPa	29.15 MPa
$\Delta P_{pr}$	83.071 kN	83.071 kN
$\frac{\Delta P_{pr}}{P_0} [\%]$	2.274%	2.274%



## 25.4 Design Process<sup>1</sup>

### Design with respect to DIN EN 1992-1-1:2004 [1] [2]

- Material:

Concrete: C 35/45

3.1: Concrete

$$E_{cm} = 34077 \text{ N/mm}^2$$

3.1.2: Tab. 3.1:  $E_{cm}$ ,  $f_{ck}$  and  $f_{cm}$  for C 35/45

$$f_{ck} = 35 \text{ N/mm}^2$$

$$f_{cm} = 43 \text{ N/mm}^2$$

Prestressing Steel: Y 1770

3.3: Prestressing Steel

$$E_p = 195000 \text{ N/mm}^2$$

3.3.6 (3):  $E_p$  for wires

$$f_{pk} = 1770 \text{ N/mm}^2$$

3.3.2, 3.3.3:  $f_{pk}$  Characteristic tensile strength of prestressing steel

$$f_{p0,1k} = 1520 \text{ N/mm}^2$$

3.3.2, 3.3.3:  $f_{p0,1k}$  0.1% proof-stress of prestressing steel, yield strength

Prestressing system: *BBV L19* 150 mm<sup>2</sup>

19 wires with area of 150 mm<sup>2</sup> each, giving a total of  $A_p = 28.5 \text{ cm}^2$

- Cross-section:

$$A_c = 1.0 \cdot 1.0 = 1 \text{ m}^2$$

Diameter of duct  $\phi_{duct} = 97 \text{ mm}$

$$\text{Ratio } \alpha_{E,p} = E_p / E_{cm} = 195000 / 34077 = 5.7223$$

$$A_{c,netto} = A_c - \pi \cdot (\phi_{duct}/2)^2 = 0.9926 \text{ m}^2$$

$$A_{ideal} = A_c + A_p \cdot \alpha_{E,p} = 1.013 \text{ m}^2$$

- Prestressing forces and stresses

The force applied to a tendon, i.e. the force at the active end during tensioning, should not exceed the following value

$$P_{max} = A_p \cdot \sigma_{p,max}$$

where  $\sigma_{p,max} = \min(0.8 \cdot f_{pk}; 0.90 \cdot f_{p0,1k})$

$$P_{max} = A_p \cdot 0.80 \cdot f_{pk} = 28.5 \cdot 10^{-4} \cdot 0.80 \cdot 1770 = 4035.6 \text{ kN}$$

$$P_{max} = A_p \cdot 0.90 \cdot f_{p0,1k} = 28.5 \cdot 10^{-4} \cdot 0.90 \cdot 1520 = 3898.8 \text{ kN}$$

$$\rightarrow P_{max} = 3898.8 \text{ kN} \text{ and } \sigma_{p,max} = 1368 \text{ N/mm}^2$$

The value of the initial prestress force at time  $t = t_0$  applied to the concrete immediately after tensioning and anchoring should not exceed the following value

5.10.3 (2): Prestress force

<sup>1</sup>The tools used in the design process are based on steel stress-strain diagrams, as defined in [1] 3.3.6: Fig. 3.10

5.10.3 (2): Eq. 5.43:  $P_{m0}$  initial prestress force at time  $t = t_0$

(NDP) 5.10.3 (2):  $\sigma_{p,m0}(x)$  stress in the tendon immediately after tensioning or transfer

$$P_{m0}(x) = A_p \cdot \sigma_{p,m0}(x)$$

$$\text{where } \sigma_{p,m0}(x) = \min \{0.75f_{pk}; 0.85f_{p0,1k}\}$$

$$P_{m0} = A_p \cdot 0.75 \cdot f_{pk} = 28.5 \cdot 10^{-4} \cdot 0.75 \cdot 1770 = 3783.4 \text{ kN}$$

$$P_{m0} = A_p \cdot 0.85 \cdot f_{p0,1k} = 28.5 \cdot 10^{-4} \cdot 0.85 \cdot 1520 = 3682.2 \text{ kN}$$

$$\rightarrow P_{m0} = 3682.2 \text{ kN and } \sigma_{p,m0} = 1292 \text{ N/mm}^2$$

Further calculations for the distribution of prestress forces and stresses along the beam are not in the scope of this benchmark and will not be described here. The complete diagram can be seen in benchmark 17, after the consideration of losses at anchorage and due to friction, as calculated by SOFiSTiK. There the values of  $\sigma_{p,max} = 1368 \text{ N/mm}^2$  and  $P_{m0} = 3682.2 \text{ kN}$  can be visualised.

In this benchmark the beam number 10010 is analysed therefore the prestressing force is obtained from TENDON:

$$P_0 = 3653 \text{ kN}$$

$$\sigma_{p,0} = 1281.755 \text{ MPa}$$

#### Calculating the prestressing losses due relaxation

According to DIN EN 1992-1-1, 3.3.2 (5), the value of  $\rho_{1000}$  is expressed as a percentage ratio of the initial stress and is obtained for an initial stress equal to  $0.7 \cdot f_p$ , where  $f_p$  is the actual tensile strength of the prestressing steel samples. For design calculations, the characteristic tensile strength ( $f_{pk}$ ) is used.

$$\mu = \frac{\sigma_{p0}}{f_{pk}} = \frac{1281.755}{1770} = 0.724155 \geq \mu_{min} = 0.55$$

**The formulas in section DIN EN 1992-1-1, 3.3.2 (7) are not used for the calculation**, according to DiBt [17] for DIN EN 1992-1-1 [6] the relaxation values are obtained from Table 25.3.

Please refer to Fig. 25.3 to see the differences between DIN EN 1992-1-1 and EN 1992-1-1 (for  $t=500000 \text{ h}$ ).

Table 25.3: Relaxation values per hour

$\mu = R/R_n$	1	10	200	1000	5000	$5 \cdot 10^5$	$1 \cdot 10^6$
0.45	< 1 %						
0.50	-						
0.55	-					1.0	1.2
0.60	-				1.2	2.5	2.8
0.65	-			1.3	2.0	4.5	5.0
0.70	-		1.0	2.0	3.0	6.5	7.0
0.75	-	1.2	2.5	3.0	4.5	9.0	10.0

Table 25.3: (continued)

$\mu = R/R_n$	1	10	200	1000	5000	$5 \cdot 10^5$	$1 \cdot 10^6$
0.80	1.0	2.0	4.0	5.0	6.5	13.0	14.0

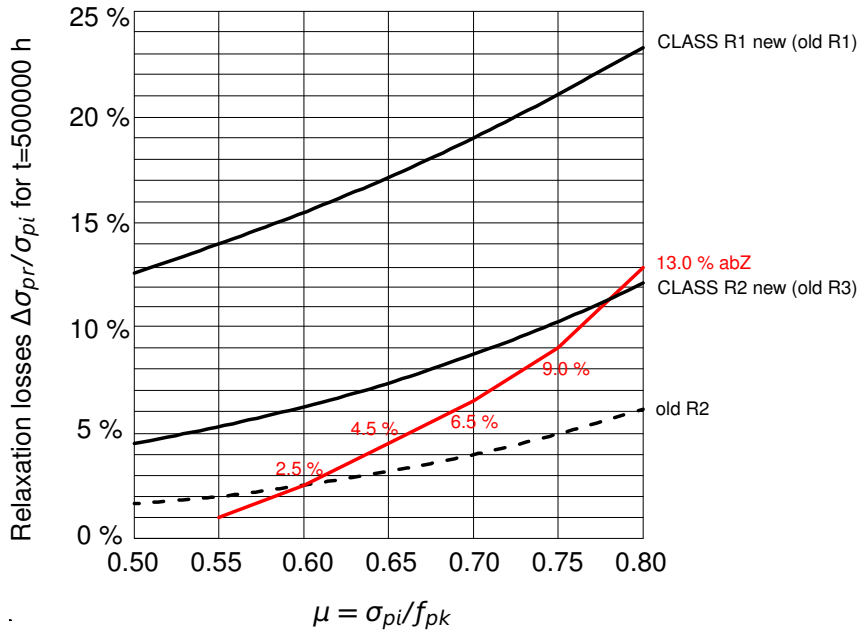

Figure 25.3: The relaxation loss differences according to EC2 and abZ (DiBt)

$t = 1000 \text{ h}$

AQB is interpolating the values from Table 25.3.

$$\frac{\Delta\sigma_{pr}}{\sigma_{pi}} = \frac{(3 - 2) \cdot (0.724 - 0.7)}{0.75 - 0.7} + 2.0 = 2.483$$

$$\Delta\sigma_{pr} = \sigma_{pi} \cdot 2.483 \% = 1281.75 \cdot 2.483\% = 31.82 \text{ MPa}$$

AQB reduces the initial stress according to DIN 1045-1:

DIN 1045-1 8.7.3 (6)

$$\Delta P_{c+s+r} = A_p \frac{\epsilon_{cs} \cdot E_p + \Delta\sigma_{pr} + \frac{E_p}{E_{cm}} \cdot \phi(t, t_0) \cdot \sigma_{c,QP}}{1 + \frac{E_p}{E_{cm}} \cdot \frac{A_p}{A_c} \left( 1 + \frac{A_c}{I_c} \cdot z_{cp}^2 \right) [1 + 0.8 \cdot \phi(t, t_0)]}$$

DIN 1045-1 8.7.3 (6):  $\Delta P_{c+s+r}$  Time dependent losses of prestress

Creep and shrinkage is not taken into account therefore we have:

$$\epsilon_{cs} \cdot E_p = 0$$

$$\frac{E_p}{E_{cm}} \cdot \phi(t, t_0) \cdot \sigma_{c,QP} = 0$$

$$1 + 0.8 \cdot \phi(t, t_0) = 1$$

$$\Delta\sigma_{p,c+s+r} = \frac{31.82}{1 + \frac{195000}{34077} \cdot \frac{28.5 \cdot 10^{-4}}{0.9926} \cdot \left(1 + \frac{0.9926}{0.08214} \cdot 0.3901^2\right)}$$

$$\Delta\sigma_{p,c+s+r} = \frac{31.82}{1.046644} = 30.402 \text{ MPa}$$

Now we have:

$$\sigma_{p0} = \sigma_{pg0} - 0.3 \cdot \Delta\sigma_{p,c+s+r}$$

DIN 1045-1 8.7.3 (6)

$$\sigma_{p0} = 1281.755 - 0.3 \cdot 30.4020 = 1272.631 \text{ MPa}$$

Now with the reduced stress the  $\mu$  value is calculated again (iteration):

$$\mu = \frac{\sigma_{p0}}{f_{pk}} = \frac{1272.631}{1770} = 0.719 \geq \mu_{min} = 0.55$$

Interpolating the relaxation values from Table 25.3:

$$\frac{\Delta\sigma_{pr}}{\sigma_{pi}} = \frac{(3 - 2) \cdot (0.719 - 0.7)}{0.75 - 0.7} + 2.0 = 2.38 \%$$

$$\Delta\sigma_{pr} = 1281.755 \cdot 2.38\% = 30.50 \text{ MPa}$$

The total loss:

$$\Delta\sigma_{pr,total} = \Delta\sigma_{pr,t} + \Delta\sigma_{pr,c}$$

$$\Delta\sigma_{pr,t} = \Delta\sigma_{pr} = 30.5093 \text{ MPa}$$

$\epsilon_{k0}$ ,  $\epsilon_{ky}$  and  $\epsilon_{kz}$  - tendon strain

$$\Delta\sigma_{pr,c} = (\epsilon_{k0} + \epsilon_{ky} \cdot z_{cp} - \epsilon_{kz} \cdot y_{cp}) \cdot E_p$$

$$\Delta\sigma_{pr,c} = (2.457 \cdot 10^{-6} + 1.15 \cdot 10^{-5} \cdot 0.39) \cdot 1.95 \cdot 10^8 / 1000$$

$$\Delta\sigma_{pr,c} = 1.354 \text{ MPa}$$

$$\Delta\sigma_{pr,total} = 30.5 - 1.354 = 29.15 \text{ MPa}$$

$$\Delta P_{pr} = \Delta\sigma_{pr,total} \cdot A_p = 29.15 \cdot 28.5 \cdot 10^{-4} \cdot 1000 = 83.071 \text{ kN}$$

Prestress-force loss in [%]:

$$\Delta P_{pr} [\%] = \frac{\Delta P_{pr}}{P_0}$$

$$\Delta P_{pr} [\%] = \frac{83.08}{3653} = 0.02274 \cdot 100\% = 2.274 \%$$

## 25.5 Conclusion

This example shows the calculation of the time dependent losses due to relaxation. It has been shown that the reference solution and the AQB solution are in very good agreement.

## 25.6 Literature

- [1] *DIN EN 1992-1-1/NA: Eurocode 2: Design of concrete structures, Part 1-1/NA: General rules and rules for buildings - German version EN 1992-1-1:2005 (D), Nationaler Anhang Deutschland - Stand Februar 2010.* CEN. 2010.
  - [2] F. Fingerloos, J. Hegger, and K. Zilch. *DIN EN 1992-1-1 Bemessung und Konstruktion von Stahlbeton- und Spannbetontragwerken - Teil 1-1: Allgemeine Bemessungsregeln und Regeln für den Hochbau.* BVPI, DBV, ISB, VBI. Ernst & Sohn, Beuth, 2012.
  - [6] *EN 1992-1-1: Eurocode 2: Design of concrete structures, Part 1-1: General rules and rules for buildings.* CEN. 2004.
  - [17] DiBt. *Allgemeine bauaufsichtliche Zulassung.* Deutsches Institut für Bautechnik. 2015.
-



## 26 DCE-EN24: Lateral Torsional Buckling

### Overview

<b>Design Code Family(s):</b>	EN
<b>Design Code(s):</b>	EN 1993-1-1
<b>Module(s):</b>	BDK
<b>Input file(s):</b>	<a href="#">eccs_119.example.5.dat</a>

### 26.1 Problem Description

The problem consists of a simply supported beam with a steel I-section, which is subjected to compression and biaxial bending, as shown in Fig. 26.1. The beam is checked against lateral torsional buckling.

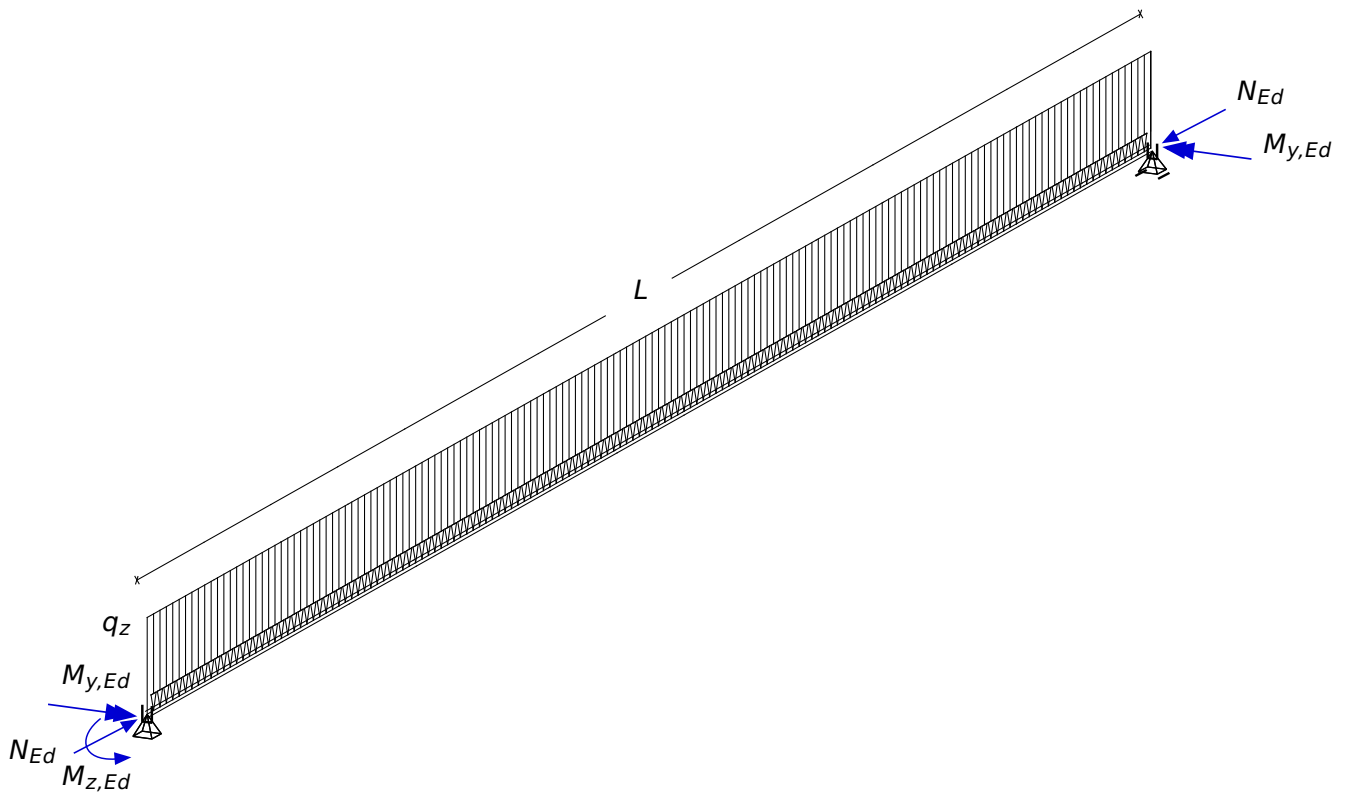

Figure 26.1: Problem Description

### 26.2 Reference Solution

This example is concerned with the buckling resistance of steel members. It deals with the spatial behavior of the beam and the occurrence of lateral torsional buckling as a potential mode of failure. The content of this problem is covered by the following parts of EN 1993-1-1:2005 [7]:

- Structural steel (Section 3.2 )
- Classification of cross-sections (Section 5.5)

- Buckling resistance of members (Section 6.3)
- Method 1: Interaction factors  $k_{ij}$  for interaction formula in 6.3.3(4) (Annex A)

## 26.3 Model and Results

The I-section, an IPE 500, with properties as defined in Table 26.1, is to be checked for lateral torsional buckling, with respect to EN 1993-1-1:2005 [7]. The calculation steps are presented below. The results are tabulated in Table 26.2 and compared to the results of reference [18].

Table 26.1: Model Properties

Material Properties	Geometric Properties	Loading
S 235	IPE 500	$M_{y,Ed} = 100 \text{ kNm}$
$E = 210000 \text{ N/mm}^2$	$L = 3.750 \text{ m}$	$M_{z,Ed} = 25 \text{ kNm}$
$\gamma_{M1} = 1.0$	$h_w = 468 \text{ mm}$	$q_z = 170 \text{ kN/m}$
	$b_f = 200 \text{ mm}$	$N_{Ed} = 500 \text{ kN}$
	$t_f = 16.0 \text{ mm}$	
	$t_w = 10.2 \text{ mm}$	
	$A = 115.5 \text{ cm}^2$	
	$I_y = 48197 \text{ cm}^4$	
	$I_z = 2142 \text{ cm}^4$	
	$I_T = 88.57 \text{ cm}^4$	
	$I_w = 1236 \times 10^3 \text{ cm}^6$	
	$W_{pl,y} = 2194 \text{ cm}^3$	
	$W_{pl,z} = 335.9 \text{ cm}^3$	
	$W_{el,y} = 1927.9 \text{ cm}^3$	
	$W_{el,z} = 214.2 \text{ cm}^3$	

Table 26.2: Results

	SOF.	Ref. [18]
$\bar{\lambda}_y$	0.195	0.195
$\chi_y$	1.0	1.0
$\bar{\lambda}_z$	0.927	0.927
$\phi_z$	1.054	1.054
$\chi_z$	0.644	0.644



Table 26.2: (continued)

	SOF.	Ref. [18]
$\mu_y$	1.000	1.000
$\mu_z$	0.937	0.937
$w_y$	1.138	1.138
$w_z$	1.500	1.500
$C_{my,0}$	1.001	0.999
$C_{mz,0}$	0.771	0.771
$C_{my}$	1.001	1.000
$C_{mz}$	0.771	0.771
$\bar{\lambda}_0$	0.759	0.757
$C_1$	1.194	1.200
$C_{mLT}$	1.139	1.137
$\bar{\lambda}_{LT}$	0.695	0.691
$\Phi_{LT}$	0.825	0.822
$\chi_{LT}$	0.787	0.789
$\chi_{LT,mod}$	0.821	0.826
$C_{yy}$	0.981	0.981
$C_{yz}$	0.862	0.863
$C_{zy}$	0.842	0.843
$C_{zz}$	1.013	1.014
$nm - y$ (Eq.6.61 [7])	0.966	0.964
$nm - z$ (Eq.6.62 [7])	0.868	0.870

## 26.4 Design Process<sup>1</sup>

Design Load:

$$M_{zEd} = 25 \text{ kNm}$$

$$M_{yEd} = -100 \text{ kNm at the start and end of the beam}$$

$$M_{yEd} = 199 \text{ kNm at the middle of the beam}$$

$$N_{Ed} = 25 \text{ kNm}$$

Tab. 5.5: Classification of cross-section

The cross-section is classified as **Class 1**, as demonstrated in [18].

6.3.1.2 (1):  $N_{cr}$  is the elastic critical force for the relevant buckling mode

$$N_{cr,y} = \frac{\pi^2 EI_y}{L^2} = 71035 \text{ kN}$$

6.3.1.2 (1):  $\bar{\lambda}$  non dimensional slenderness for class 1 cross-sections

$$\bar{\lambda}_y = \sqrt{\frac{A f_y}{N_{cr,y}}} = 0.195$$

6.3.1.2 (4):  $\bar{\lambda} \leq 0.2$  buckling effects may be ignored

$$\bar{\lambda}_y < 0.2 \text{ thus } \chi_y = 1.0$$

$$N_{cr,z} = \frac{\pi^2 EI_z}{L^2} = 3157 \text{ kN}$$

$$\bar{\lambda}_z = \sqrt{\frac{A f_y}{N_{cr,z}}} = 0.927$$

$$\Phi_z = 0.5 \left[ 1 + \alpha_z (\bar{\lambda}_z - 0.2) + \bar{\lambda}_z^2 \right]$$

for rolled I-sections with  $h / b > 1.2$  and buckling about z-z axis  $\rightarrow$  buckling curve b

6.3.1.2 (2): Table 6.1: Imperfection factors for buckling curves

for buckling curve b  $\rightarrow \alpha_z = 0.34$

$$\Phi_z = 1.054$$

6.3.1.2 (1): Eq. 6.49:  $\chi_z$  reduction factor for buckling

$$\chi_z = \frac{1}{\Phi_z + \sqrt{\Phi_z^2 - \bar{\lambda}_z^2}} = 0.644 \leq 1.0$$

The stability verification will be done according to Method 1-Annex A of EN 1993-1-1:2005 [7]. Therefore we need to identify the interaction factors according to tables A.1-A.2 of Annex A, EN 1993-1-1:2005 [7].

**Auxiliary terms:**

$$\mu_y = \frac{1 - \frac{N_{Ed}}{N_{cr,y}}}{1 - \chi_y \frac{N_{Ed}}{N_{cr,y}}} = 1.0$$

Annex A: Tab. A.1: Interaction factors  $k_{ij}$  (6.3.3(4)), Auxiliary terms

<sup>1</sup>The sections mentioned in the margins refer to EN 1993-1-1:2005 [7] unless otherwise specified.

$$\mu_z = \frac{1 - \frac{N_{Ed}}{N_{cr,z}}}{1 - \chi_z \frac{N_{Ed}}{N_{cr,z}}} = 0.937$$

$$w_y = \frac{W_{pl,y}}{W_{el,y}} = 1.138 \leq 1.5$$

$$w_z = \frac{W_{pl,z}}{W_{el,z}} = 1.568 > 1.5 \rightarrow w_z = 1.5$$

### Determination of $C_{mi,0}$ factors

The general formula for combined end moments and transverse loads is used here.

$$C_{my,0} = 1 + \left( \frac{\pi^2 EI_y |\delta_z|}{L^2 |M_{y,Ed,right}|} - 1 \right) \frac{N_{Ed}}{N_{cr,y}}$$

$$\delta_z = 3.33 \text{ mm}$$

$$C_{my,0} = 1.001$$

The formula for linearly distributed bending moments is used here.

$$\psi_z = \frac{M_{z,ED,right}}{M_{z,Ed,left}} = 0/25 = 0$$

$$C_{mz,0} = 0.79 + 0.21\psi_z + 0.36(\psi_z - 0.33) \frac{N_{Ed}}{N_{cr,z}} = 0.771$$

$$C_{mz} = C_{mz,0} = 0.771$$

### Resistance to lateral torsional buckling

Because  $I_T = 8.857 \times 10^{-7} \text{ m}^4 < I_y = 4.820 \times 10^{-4} \text{ m}^4$ , the cross-section shape is such that the member may be prone to lateral torsional buckling.

The support conditions of the member are assumed to be the so-called "fork conditions", thus  $L_{LT} = L$ .

$$M_{cr,0} = \sqrt{\frac{\pi^2 EI_z}{L_{LT}^2} \left( GI_T + \frac{\pi^2 EI_w}{L_{LT}^2} \right)} = 895 \text{ kNm}$$

$$\bar{\lambda}_0 = \sqrt{\frac{W_{pl,y} f_y}{M_{cr,0}}} = 0.759$$

$$N_{cr,T} = \frac{A}{I_y + I_z} \left( GI_T + \frac{\pi^2 EI_w}{L_{LT}^2} \right) = 5822 \text{ kN}$$

$C_1 = 1.194$  determined by eigenvalue analysis

$$\bar{\lambda}_{olim} = 0.2 \sqrt{C_1} \sqrt[4]{\left( 1 - \frac{N_{Ed}}{N_{cr,z}} \right) \left( 1 - \frac{N_{Ed}}{N_{cr,T}} \right)} = 0.205$$

Annex A: Tab. A.2: Equivalent uniform moment factors  $C_{mi,0}$

Annex A: Tab. A.1:  $\bar{\lambda}_0$ : non-dimensional slenderness for lateral-torsional buckling due to uniform bending moment

Annex A: Tab. A.1: Auxiliary terms

$$\bar{\lambda}_0 = 0.759 \geq \bar{\lambda}_{0lim} = 0.205$$

Lateral torsional buckling has to be taken into account.

Annex A: Tab. A.1: Auxiliary terms

$$\alpha_{LT} = 1 - \frac{I_T}{I_y} = 0.998 \geq 0$$

Annex A: Tab. A.1:  $\epsilon_y$  for class 1 cross-section

$$\epsilon_y = \frac{M_{y,Ed,right}}{N_{Ed}} \frac{A}{W_{el,y}} = 2.383$$

$$C_{my} = C_{my,0} + (1 - C_{my,0}) \frac{\alpha_{LT} \sqrt{\epsilon_y}}{1 + \alpha_{LT} \sqrt{\epsilon_y}} = 1.001$$

$$C_{mLT} = C_{my}^2 \frac{\alpha_{LT}}{\sqrt{\left(1 - \frac{N_{Ed}}{N_{cr,z}}\right) \left(1 - \frac{N_{Ed}}{N_{cr,t}}\right)}} = 1.139 \geq 1.0$$

thus  $C_{mLT} = 1.0$ .

6.3.2.2: Lateral torsional buckling curves - General case

The general case method is chosen here.

$M_{cr} = 1068 \text{ kNm}$ , determined by eigenvalue analysis

6.3.2.2 (1):  $\bar{\lambda}_{LT}$  non dimensional slenderness for lateral torsional buckling

$$\bar{\lambda}_{LT} = \sqrt{\frac{W_{pl,y} f_y}{M_{cr}}} = \sqrt{\frac{2194 \cdot 10^{-6} \cdot 235 \cdot 10^6}{1079 \cdot 10^3}} = 0.695$$

$$\Phi_{LT} = 0.5 \left[ 1 + \alpha_{LT} (\bar{\lambda}_{LT} - 0.2) + \bar{\lambda}_{LT}^2 \right]$$

6.3.2.2 (1): Table 6.4: Recommendation for the selection of ltb curve for cross-sections using Eq. 6.56

for rolled I-sections and  $h / b > 2 \rightarrow$  buckling curve b

6.3.2.2 (2): Table 6.4: Recommendation values for imperfection factors  $\alpha_{LT}$  for ltb curves

for buckling curve b  $\rightarrow \alpha_{LT} = 0.34$

$$\Phi_{LT} = 0.825$$

6.3.2.2 (1): Eq. 6.56:  $\chi_{LT}$  reduction factor for ltb

$$\chi_{LT} = \frac{1}{\Phi_{LT} + \sqrt{\Phi_{LT}^2 - \bar{\lambda}_{LT}^2}}$$

$$\chi_{LT} = 0.787 \leq 1.0$$

$k_c = 0.907$  determined by eigenvalue analysis through the  $C_1$  factor.

6.3.2.3 (2): For taking into account the moment distribution between the lateral restraints of members the reduction factor  $\chi_{LT}$  may be modified

$$f = 1 - 0.5(1 - k_c) \left[ 1 - 2(\bar{\lambda}_{LT} - 0.8)^2 \right] = 0.959 \leq 1.0$$

$$\chi_{LT,mod} = \frac{\chi_{LT}}{f} = 0.821 \leq 1.0$$

Elastic-plastic bending resistances

$$N_{c,Rk} = A \cdot f_y = 2715 \text{ kN}$$

$$M_{pl,y,Rk} = W_{pl,y} \cdot f_y = 516 \text{ kNm}$$

$$M_{pl,z,Rk} = W_{pl,z} \cdot f_y = 78.9 \text{ kNm}$$

$$\bar{\lambda}_{max} = \bar{\lambda}_z = 0.927$$

$$b_{LT} = 0.5 \cdot \alpha_{LT} \cdot \bar{\lambda}_0^{-2} \frac{M_{y,Ed}}{\chi_{LT,mod} \frac{M_{pl,y,Rk}}{\gamma_{M1}}} \frac{M_{z,Ed}}{M_{pl,z,Rk} \frac{\gamma_{M1}}{\gamma_{M1}}} = 0.428$$

Annex A: Tab. A.1: Auxiliary terms:  
 $\bar{\lambda}_{max} = \max(\bar{\lambda}_y, \bar{\lambda}_z)$

Annex A: Tab. A.1: Auxiliary terms

$$C_{yy} = 1 + (w_y - 1) \left[ \left( 2 - \frac{1.6}{w_y} \cdot C_{my}^2 \bar{\lambda}_{max} - \frac{1.6}{w_y} \cdot C_{my}^2 \bar{\lambda}_{max}^2 \right) \cdot \frac{N_{Ed}}{N_{c,Rk} \frac{\gamma_{M1}}{\gamma_{M1}}} - b_{LT} \right]$$

$$C_{yy} = 0.981 \geq \frac{W_{el,y}}{W_{pl,y}} = 0.879$$

$$c_{LT} = 10 \cdot \alpha_{LT} \cdot \frac{\bar{\lambda}_0^{-2}}{5 + \bar{\lambda}_z^{-4}} \frac{M_{y,Ed}}{C_{my} \cdot \chi_{LT,mod} \frac{M_{pl,y,Rk}}{\gamma_{M1}}} = 0.471$$

$$C_{yz} = 1 + (w_z - 1) \left[ \left( 2 - 14 \frac{C_{my}^2 \bar{\lambda}_{max}^2}{w_z^5} \right) \frac{N_{Ed}}{N_{c,Rk} \frac{\gamma_{M1}}{\gamma_{M1}}} - c_{LT} \right]$$

$$C_{yz} = 0.862 \geq 0.6 \sqrt{\frac{w_z}{w_y} \frac{W_{el,z}}{W_{pl,z}}} = 0.439$$

$$d_{LT} = 2 \cdot \alpha_{LT} \cdot \frac{\bar{\lambda}_0}{0.1 + \bar{\lambda}_z^{-4}} \frac{M_{y,Ed}}{C_{my} \cdot \chi_{LT,mod} \frac{M_{pl,y,Rk}}{\gamma_{M1}}} \frac{M_{z,Ed}}{C_{mz} \frac{M_{pl,z,Rk}}{\gamma_{M1}}} = 0.348$$

$$C_{zy} = 1 + (w_y - 1) \left[ \left( 2 - 14 \frac{C_{my}^2 \bar{\lambda}_{max}^2}{w_y^5} \right) \frac{N_{Ed}}{N_{c,Rk} \frac{\gamma_{M1}}{\gamma_{M1}}} - d_{LT} \right]$$

$$C_{zy} = 0.842 \geq 0.6 \sqrt{\frac{w_y}{w_z} \frac{W_{el,y}}{W_{pl,y}}} = 0.459$$

$$e_{LT} = 1.7 \cdot \alpha_{LT} \cdot \frac{\bar{\lambda}_0}{0.1 + \bar{\lambda}_z^{-4}} \frac{M_{y,Ed}}{C_{my} \cdot \chi_{LT,mod} \frac{M_{pl,y,Rk}}{\gamma_{M1}}} = 0.721$$

$$C_{zz} = 1 + (w_z - 1) \left[ \left( 2 - \frac{1.6}{w_z} \cdot C_{mz}^2 \bar{\lambda}_{max} - \frac{1.6}{w_z} \cdot C_{mz}^2 \bar{\lambda}_{max}^2 - e_{LT} \right) \cdot \frac{N_{Ed}}{N_{c,Rk}} \right] \frac{1}{\gamma_{M1}}$$

$$C_{zz} = 1.013 \geq \frac{W_{el,z}}{W_{pl,z}} = 0.667$$

## Verification

According to 1993-1-1:2005, 6.3.3 (4), members which are subjected to combined bending and axial compression should satisfy:

$$\frac{N_{Ed}}{\chi_y \frac{N_{c,Rk}}{\gamma_{M1}}} + \mu_y \left[ \frac{C_{mLT}}{\chi_{LT,mod}} \frac{C_{my} \cdot M_{y,Ed}}{\left(1 - \frac{N_{Ed}}{N_{cr,y}}\right) C_{yy} \cdot \frac{M_{pl,y,Rk}}{\gamma_{M1}}} \right. \\ \left. + 0.6 \sqrt{\frac{w_z}{w_y}} \frac{C_{mz} M_{z,Ed}}{\left(1 - \frac{N_{Ed}}{N_{cr,z}}\right) C_{yz} \frac{M_{pl,z,Rk}}{\gamma_{M1}}} \right]$$

$$\frac{500}{1.0 \frac{2715}{1.0}} + 1.0 \left[ \frac{1.139}{0.821} \frac{1.001 \cdot 198.9}{\left(1 - \frac{500}{71035}\right) 0.981 \frac{516}{1.0}} \right. \\ \left. + 0.6 \sqrt{\frac{1.500}{1.138}} \frac{0.771 \cdot 25}{\left(1 - \frac{500}{3157}\right) 0.862 \frac{78.9}{1.0}} \right] \\ = 0.966 \leq 1.00$$

→ Satisfactory

$$\frac{N_{Ed}}{\chi_z \frac{N_{c,Rk}}{\gamma_{M1}}} + \mu_z \left[ 0.6 \sqrt{\frac{w_y}{w_z}} \frac{C_{mLT}}{\chi_{LT,mod}} \frac{C_{my} \cdot M_{y,Ed}}{\left(1 - \frac{N_{Ed}}{N_{cr,y}}\right) C_{zy} \frac{M_{pl,y,Rk}}{\gamma_{M1}}} \right. \\ \left. + \frac{C_{mz} M_{z,Ed}}{\left(1 - \frac{N_{Ed}}{N_{cr,z}}\right) C_{zz} \frac{M_{pl,z,Rk}}{\gamma_{M1}}} \right]$$

$$\frac{500}{0.644 \frac{2715}{1.0}} + 0.937 \left[ +0.6 \sqrt{\frac{1.138}{1.500}} \frac{1.139}{0.821} \right. \\ \left. \cdot \frac{1.001 \cdot 198.9}{\left(1 - \frac{500}{71035}\right) 0.842 \frac{516}{1.0}} + \frac{0.771 \cdot 25}{\left(1 - \frac{500}{3157}\right) 1.013 \frac{78.9}{1.0}} \right]$$

6.3.3 Uniform members in bending and axial compression

6.3.3 (4): Eq. 6.61: Members which are subjected to combined bending and axial compression should satisfy:

6.3.3 (4): Eq. 6.62: Members which are subjected to combined bending and axial compression should satisfy:

$$= 0.868 \leq 1$$

→ Satisfactory



## 26.5 Conclusion

This example shows the check for lateral torsional buckling of steel members. The small deviations that occur in some results come from the fact that there are some small differences in the sectional values between SOFiSTiK and the reference solution. Therefore, these deviations are of no interest for the specific verification process. In conclusion, it has been shown that the results are reproduced with excellent accuracy.

## 26.6 Literature

- [7] *EN 1993-1-1: Eurocode 3: Design of concrete structures, Part 1-1: General rules and rules for buildings*. CEN. 2005.
  - [18] ECCS Technical Committee 8 Stability. *Rules for Member Stability in EN 1993-1-1, Background documentation and design guidelines*. Tech. rep. No 119. European Convention for Constructional Steelwork (ECCS), 2006.
-



## 27 DCE-EN25: Shear between web and flanges of Hollow CS acc. DIN EN 1992-2

### Overview

<b>Design Code Family(s):</b>	DIN
<b>Design Code(s):</b>	DIN EN 1992-1-1, DIN EN 1992-2
<b>Module(s):</b>	AQB
<b>Input file(s):</b>	<a href="#">hollow_shear_web_flange.dat</a>

### 27.1 Problem Description

The problem consists of a Hollow section, as shown in Fig. 27.1. The cs is designed for shear, the shear between web and flanges of the Hollow CS is considered and the required reinforcement is determined.

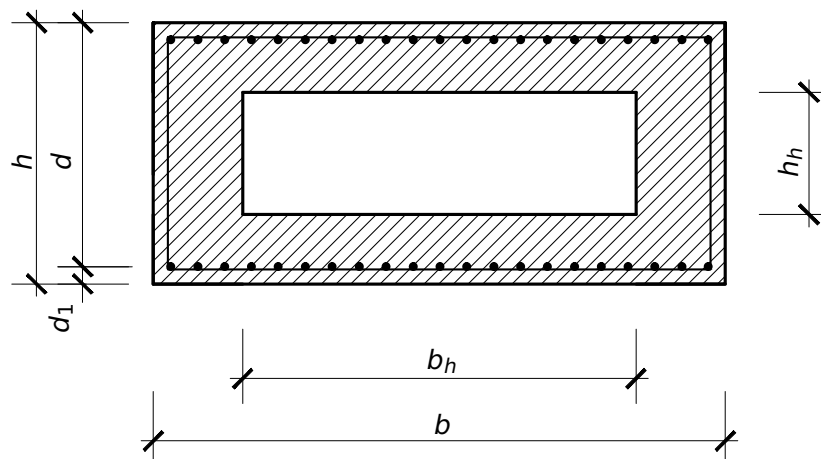

Figure 27.1: Problem Description

### 27.2 Reference Solution

This example is concerned with the shear design of Hollow-sections, for the ultimate limit state. The content of this problem is covered by the following parts of DIN EN 1992-2:2010 [19] and DIN EN 1992-1-1:2004 [1]:

- Design stress-strain curves for concrete and reinforcement (Section 3.1.7, 3.2.7)
- Guidelines for shear design (Section 6.2)

The design stress-strain diagram for reinforcing steel considered in this example, consists of an inclined top branch, as presented in Fig. 27.2 and as defined in DIN EN 1992-1-1:2004 [1] (Section 3.2.7).

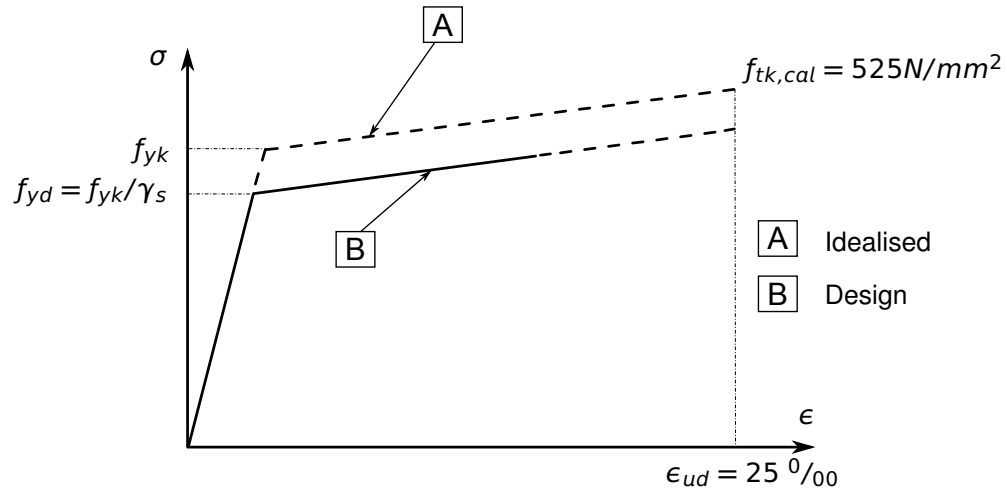

Figure 27.2: Idealised and Design Stress-Strain Diagram for Reinforcing Steel

### 27.3 Model and Results

The Hollow-section, with properties as defined in Table 27.1, is to be designed for shear, with respect to DIN EN 1992-2:2010 (German National Annex) [19]. The structure analysed, consists of a single span beam with a distributed load in gravity direction. The cross-section geometry, as well as the shear cut under consideration can be seen in Fig. 27.3.

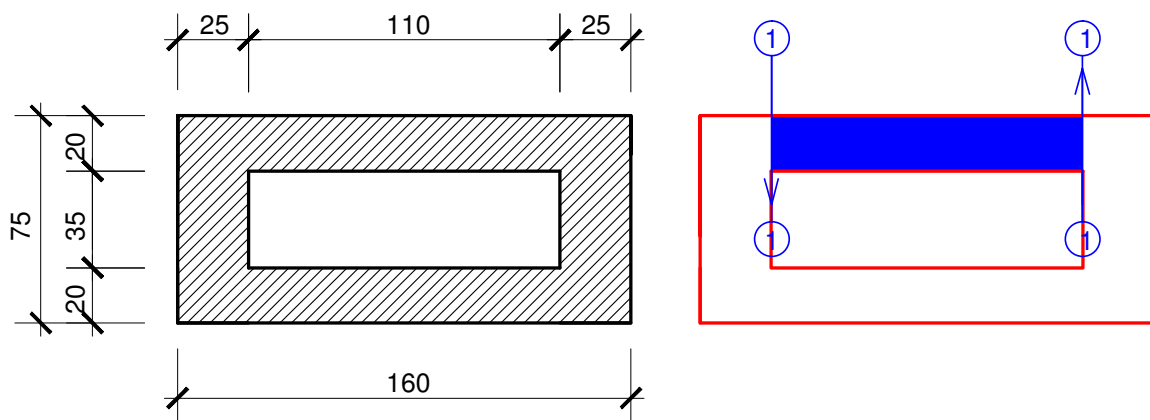

Figure 27.3: Cross-section Geometry, Properties and Shear Cuts in cm

Table 27.1: Model Properties

Material Properties	Geometric Properties	Loading
C 30/37	$h_h = 35 \text{ cm}, h = 75.0 \text{ cm}$	$P_g = 155 \text{ kN/m}$
B 500B	$h_f = 20 \text{ cm}$ $d_1 = 5.0 \text{ cm}$ $b_h = 110 \text{ cm}, b = 160 \text{ cm}$	$M_t = 100 \text{ kN/m}$

The system with its loading as well as the moment and shear force are shown in Fig. 27.4-27.7. The reference calculation steps are presented in the next section and the results are given in Table 27.2.

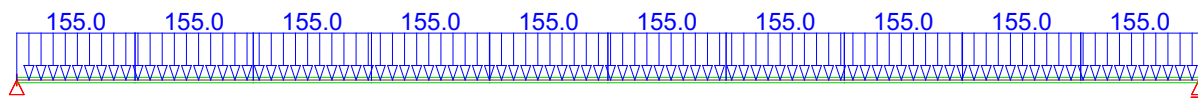

Figure 27.4: Loaded Structure ( $P_g$ )

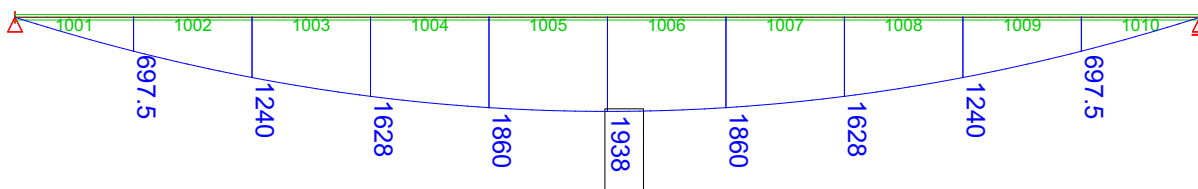

Figure 27.5: Resulting Bending Moment  $M_y$

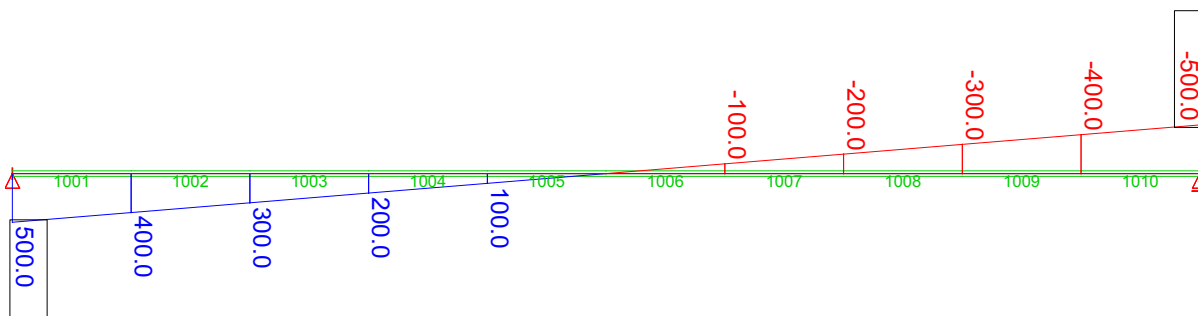

Figure 27.6: Resulting Torsional Moment  $M_t$

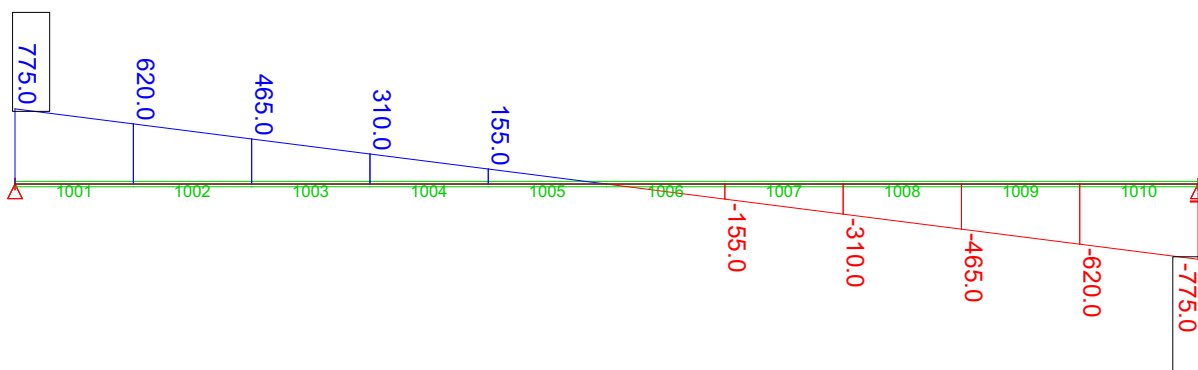

Figure 27.7: Resulting Shear Force  $V_z$

Table 27.2: Results

At beam 1001	SOF.	Ref.
$A_{s1}$ [ $cm^2$ ] at $x = 1.0$ m	22.50	22.52
$V_{Rd,c}$ [kN]	91.91	91.91

Table 27.2: (continued)

At beam 1001	SOF.	Ref.
$V_{Rd,max}$ [kN]	1098.43	1098.461
$\cot \theta$	1.75	1.75
$z$ [cm] at $x = 1.0$ m	63.00	67.00
$V_{Ed} = \Delta F_d$ [kN]	346.61	352.35
$a_{sf,left}$ ( $x=0.00$ ) [ $cm^2$ ]	8.58	8.64
$a_{sf,right}$ ( $x=0.00$ ) [ $cm^2$ ]	0.53	0.61
$a_{sf,left}$ ( $x=1.00$ ) [ $cm^2$ ]	7.77	7.83
$a_{sf,right}$ ( $x=1.00$ ) [ $cm^2$ ]	1.34	1.43

## 27.4 Design Process<sup>1</sup>

Design with respect to DIN EN 1992-2:2010 (NA) [19]:<sup>2</sup>

Material:

Concrete:  $\gamma_c = 1.50$

Steel:  $\gamma_s = 1.15$

$f_{ck} = 30 \text{ MPa}$

$f_{cd} = a_{cc} \cdot f_{ck} / \gamma_c = 0.85 \cdot 30 / 1.5 = 17 \text{ MPa}$

$f_{yk} = 500 \text{ MPa}$

$f_{yd} = f_{yk} / \gamma_s = 500 / 1.15 = 434.78 \text{ MPa}$

$\sigma_{sd} = 456.52 \text{ MPa}$

(NDP) 2.4.2.4: (1), Tab. 2.1DE: Partial factors for materials

Tab. 3.1: Strength for concrete

3.1.6: (1)P, Eq. (3.15):  $a_{cc} = 0.85$  considering long term effects

3.2.2: (3)P: yield strength  $f_{yk} = 500 \text{ MPa}$

3.2.7: (2), Fig. 3.8

### Design loads

- Design Load for beam 1001,  $x=0.0 \text{ m}$ :

$M_{Ed, x=0.0 \text{ m}} = 0.0 \text{ kNm}$

- Design Load for beam 1001,  $x=1.0 \text{ m}$ :

$M_{Ed, x=1.0 \text{ m}} = 697.5 \text{ kNm}$

### Calculating the longitudinal reinforcement:

- For beam 1001,  $x=0.0 \text{ m}$

$$\mu_{Eds} = \frac{M_{Eds}}{b_{eff} \cdot d^2 \cdot f_{cd}} = \frac{0.0 \cdot 10^{-3}}{1.60 \cdot 0.70^2 \cdot 17.00} = 0.00$$

$\mu = 0 \rightarrow A_{s1} = 0$

- For beam 1001,  $x=1.0 \text{ m}$

$$\mu_{Eds} = \frac{M_{Eds}}{b_{eff} \cdot d^2 \cdot f_{cd}} = \frac{697.5 \cdot 10^{-3}}{1.60 \cdot 0.70^2 \cdot 17.00} = 0.0523$$

$\omega \approx 0.053973$ ,  $\zeta \approx 0.9658$ ,  $\xi = 0.07833$  (interpolated)

Tab. 9.2 [3]:  $\omega$ —Table for up to C50/60 without compression reinforcement

$$A_{s1} = \frac{1}{\sigma_{sd}} \cdot (\omega \cdot b \cdot d \cdot f_{cd} + N_{Ed})$$

$N_{Ed} = 0$

$$A_{s1} = \frac{1}{456.52} \cdot (0.053973 \cdot 1.6 \cdot 0.7 \cdot 17.0) \cdot 100^2 = 22.52 \text{ cm}^2$$

$z = \zeta \cdot d = 0.9658 \cdot 0.70 \text{ m} \approx 67.00 \text{ cm}$

### Calculating the shear between flange and web

The shear force, is determined by the change of the longitudinal force, at the junction between one side of a flange and the web, in the separated flange:

6.2.4 (3): Eq. 6.20

<sup>1</sup>The tools used in the design process are based on steel stress-strain diagrams, as defined in [1] 3.2.7:(2), Fig. 3.8, which can be seen in Fig. 27.2.

<sup>2</sup>The sections mentioned in the margins refer to DIN EN 1992-1-1:2004 (German National Annex) [19], unless otherwise specified.

$$x = 0.0738 \cdot d = 0.07833 \cdot 70 = 5.48 \text{ cm} < h_f = 20 \text{ cm}$$

$$\Delta F_d = \left( \frac{M_{Ed,x=1.0}}{z} - \frac{M_{Ed,x=0.0}}{z} \right) \cdot \frac{h_f \cdot b}{h_f \cdot b_h}$$

For beam 1001 ( $x=0.00 \text{ m}$ )  $\rightarrow M_{Ed} = 0.00$  therefore:

In AQB output  $\Delta F_d = T[\text{kN/m}]$

$$\Delta F_d = \left( \frac{697.5}{0.68047} - 0 \right) \cdot \frac{1.1}{1.6} = 352.35 \cdot 2 = 704.70 \text{ kN}$$

The longitudinal shear stress  $v_{Ed,V}$  at the junction between one side of a flange and the web is determined by the change of the normal (longitudinal) force in the part of the flange considered, according to:

$$v_{Ed,V} = \frac{\frac{\Delta F_d}{2}}{h_f \cdot \Delta x}$$

DIN EN 1992, 6.2.4 (3), Eq. 6.20:  $h_f$  is the thickness of flange at the junctions,  $\Delta x$  is the length under consideration,  $\Delta F_d$  is the change of the normal force in the flange over the length  $\Delta x$

In our case  $\Delta x = 1.0$  because the beam length is = 1.00 m.

Please note that AQB is outputting the results per length.

In AQB output  $v_{Ed,V} = \tau - V$

$$v_{Ed,V} = \frac{352.35}{20 \cdot 100} = 0.176 \text{ kN/m}^2 = 1.76 \text{ MPa}$$

### Checking the maximum $v_{Rd,max}$ value to prevent crushing of the struts in the flange

To prevent crushing of the compression struts in the flange, the following condition should be satisfied:

DIN EN 1992, 6.2.4 (4), Eq. 6.22

$$v_{Ed,V} \leq v_{Rd,max} = v \cdot f_{cd} \cdot \sin \theta_f \cdot \cos \theta_f$$

$$v_{Rd,max} = v \cdot f_{cd} \cdot \sin \theta_f \cdot \cos \theta_f$$

According to DIN EN 1992-2, NDP 6.2.4:

$$v = v_1$$

DIN EN 1992, NDP 6.2.3 (3), Eq. 6.22

$$v_1 = 0.75 \cdot v_2$$

$$v_2 = 1.1 - \frac{f_{ck}}{500} \leq 1.0$$

$$v_2 = 1.1 - \frac{30}{500} = 1.1 - 0.06 = 1.04 \geq 1.0 \rightarrow v_2 = 1.0$$

$$v_1 = 0.75 \cdot 1.0 = 0.75 \rightarrow v = 0.75$$

The  $\theta$  value is calculated:

DIN EN 1992-2, NDP 6.2.3 (2), Eq. NA.6.bDE:  $\sigma_{cd} = N_{Ed}/A_c$ ,  $c=0.5$

$$v_{Rd,cc} = c \cdot 0.48 \cdot f_{ck}^{1/3} \cdot \left( 1 - 1.2 \cdot \frac{\sigma_{cd}}{f_{cd}} \right) \cdot b_w \cdot z$$

$$b_w \rightarrow h_f, \quad z \rightarrow \Delta x, \quad c = 0.5$$

$$v_{Rd,cc} = c \cdot 0.48 \cdot f_{ck}^{1/3} \cdot \left( 1 - 1.2 \cdot \frac{\sigma_{cd}}{f_{cd}} \right) \cdot h_f \cdot \Delta x$$

$$v_{Rd,cc} (x=0.0 \text{ m}) = 0.5 \cdot 0.48 \cdot 30^{1/3} \cdot \left( 1 - 1.2 \cdot \frac{0}{17.00} \right) \cdot 0.20 \cdot 1.0$$



$$V_{Rd,cc} (x=0.0 \text{ m}) = 0.14914 \text{ MN} = 149.1471 \text{ kN}$$

$$V_{Rd,cc} (x=1.0 \text{ m}) = 0.5 \cdot 0.48 \cdot 30^{1/3} \cdot \left(1 - 1.2 \cdot \frac{1.069}{17.00}\right) \cdot 0.20 \cdot 1.0$$

$$V_{Rd,cc} (x=1.0 \text{ m}) = 0.137892 \text{ MN} = 137.892 \text{ kN}$$

$$1.0 \leq \cot \theta \leq \frac{1.2 + 1.4 \cdot \Delta\sigma_{cd}/f_{cd}}{1 - V_{Rd,cc} (x=0.0 \text{ m})/V_{Ed}} \leq 1.75$$

$$1.0 \leq \cot \theta \leq \frac{1.2 + 1.4 \cdot \Delta\sigma_{cd}/f_{cd}}{1 - V_{Rd,cc} (x=1.0 \text{ m})/V_{Ed}} \leq 1.75$$

DIN EN 1992-2, NDP 6.2.3 (2), Eq. NA.6.107aDE

Because  $M_T \neq 0.0 \rightarrow \tau_T \neq 0.0$ :

$$V_{Rd,cc} (x=0.00) = \frac{V_{Rd,cc}}{h_f \cdot \Delta x}$$

$$V_{Rd,cc} (x=0.00) = \frac{149.1471}{20 \cdot 100} = 0.0745 \text{ kN/cm}^2 = 0.745 \text{ MPa}$$

$$V_{Rd,cc} (x=1.00) = \frac{V_{Rd,cc}}{h_f \cdot \Delta x}$$

$$V_{Rd,cc} (x=1.00) = \frac{137.892}{20 \cdot 100} = 0.068946 \text{ kN/cm}^2 = 0.689 \text{ MPa}$$

The internal forces must be in equilibrium, see Fig. 27.8!!! If the internal forces are not in equilibrium state, then AQB will print erroneous results. Therefore the internal forces must be taken from the system (calculated by using e.g. ASE or STAR2).

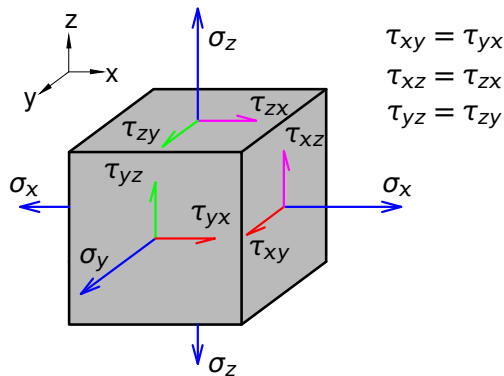

Figure 27.8: Stress equilibrium

$$\cot \theta_{(x=0.0)} = \frac{1.2}{1 - 0.745/1.76} = 2.0807 \geq 1.75 \rightarrow 1.75$$

$$\cot \theta_{(x=1.0)} = \frac{1.2 + 1.4 \cdot 1.069/17}{1 - 0.689/1.76} = 2.11 \geq 1.75 \rightarrow 1.75$$

AQB is checking and iterating if the  $\cot \theta$  is less than (<) the maximum  $\cot \theta$  defined in the norm. If yes, then this value will be taken by AQB.

$$\tan \theta = \frac{1}{\cot \theta} = \frac{1}{1.75} = 0.5714 \rightarrow \theta = 29.74488^\circ$$

$$v_{Rd,max} = 0.75 \cdot 17.00 \cdot \sin 29.7448 \cdot \cos 29.7448 = 5.492 \text{ MPa}$$

$$V_{Rd,max} = v_{Rd,max} \cdot h_f \cdot \Delta x = 5.492 \cdot 0.20 \cdot 1.0 = 1.098 \text{ MN}$$

$$V_{Rd,max} = 1098.461 \text{ kN}$$

### Checking the value $v_{Rd,c}$

If  $v_{Ed}$  is less than or equal to  $v_{Rd,c} = k \cdot f_{ctd}$  no extra reinforcement above that for flexure is required.

$$v_{Rd,c} = k \cdot f_{ctd}$$

For concrete C 30/37  $\rightarrow f_{ctd} = 1.15 \text{ MPa}$

$$v_{Rd,c} = 0.4 \cdot 1.15 = 0.46 \text{ MPa}$$

$$V_{Rd,c} = v_{Rd,c} \cdot h_f \cdot \Delta x = 0.46 \cdot 20 \cdot 100 \approx 91.91 \text{ kN}$$

- Calculating the necessary transverse reinforcement ( $\tau_v$  only):

DIN EN 1992, 6.2.4 (4), Eq. 6.21

$$a_{sf,v} = \frac{v_{Ed} \cdot h_f}{\cot \theta_f \cdot f_{yd}}$$

$$a_{sf,v} = \frac{1.76 \cdot 0.20}{1.75 \cdot 434.78} \cdot 100^2 = 4.63 \text{ cm}^2$$

- Calculating the necessary torsional reinforcement:

**HINT:** Please note that in AQB the torsional stress **IS NOT** calculated by using the formula:

$$\tau_t = \frac{M_t}{2 \cdot A_k \cdot t_{eff}}$$

AQB is calculating the  $\tau_t$  stresses by multiplying  $M_t$  with the torsional resistance  $1/W_t$  (from AQUA - calculated by using FEM).

$$\tau_t = M_t \cdot 1/W_t$$

From AQUA the torsional resistance value  $1/W_t$  is interpolated and  $1/W_t = 2.8841 \text{ 1/m}^3$ . To see the values  $1/W_t$  input ECHO FULL EXTR in AQUA and see table "Construction and Selected Result Points".

$$\tau_t (x=0.00) = 3.06 \cdot 500 \cdot 10^{-3} = 1.53 \text{ MPa}$$

$$a_{sf,T} (x=0.00) = \frac{\tau_t \cdot t_{eff}}{\cot \theta_f \cdot f_{yd}} = \frac{1.53 \cdot 0.20}{1.75 \cdot 434.78} \cdot 100^2 = 4.02 \text{ cm}^2$$

$$\tau_t (x=1.00) = 2.44 \cdot 500 \cdot 10^{-3} = 1.22 \text{ MPa}$$

$$a_{sf,T} (x=1.00) = \frac{\tau_t \cdot t_{eff}}{\cot \theta_f \cdot f_{yd}} = \frac{1.22 \cdot 0.20}{1.75 \cdot 434.78} \cdot 100^2 = 3.20 \text{ cm}^2$$

- Total reinforcement:

$$a_{sf,left} (x=0.00) = a_{sf,v} + a_{sf,T} = 4.63 + 4.02 = 8.64 \text{ cm}^2$$

$$a_{sf,right} (x=0.00) = |a_{sf,v} - a_{sf,T}| = |4.63 - 4.02| = 0.61 \text{ cm}^2$$

$$a_{sf, left} (x=1.00) = a_{sf, V} + a_{sf, T} = 4.63 + 3.20 = 7.83 \text{ cm}^2$$

$$a_{sf, right} (x=1.00) = |a_{sf, V} - a_{sf, T}| = |4.63 - 3.20| = 1.43 \text{ cm}^2$$

## 27.5 Conclusion

This example is concerned with the calculation of the shear between web and flanges of a Hollow CS. It shows partially the work-flow how AQB calculates the shear between web and flanges.

Please note that it is very difficult to show all steps how AQB calculates internally the  $\tau$  and  $\sigma$  stresses, therefore some steps are skipped. The reference example is just an approximation that shows the results by using hand-calculation. It has been shown that the results calculated by using hand-calculation and the AQB module are reproduced with very good accuracy.

The  $\tau_t$  and  $\tau_v$  values between cross-section points are interpolated and calculated by using Finite Element Method.

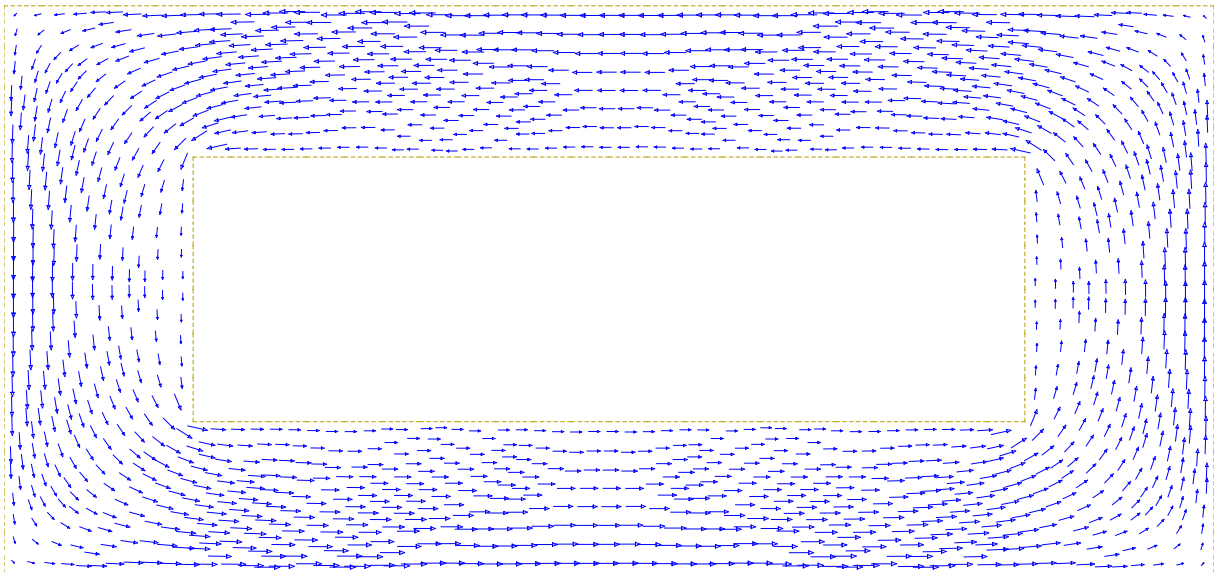

Figure 27.9: The  $\tau_t$  stresses (vector) calculated by using Finite Element Method

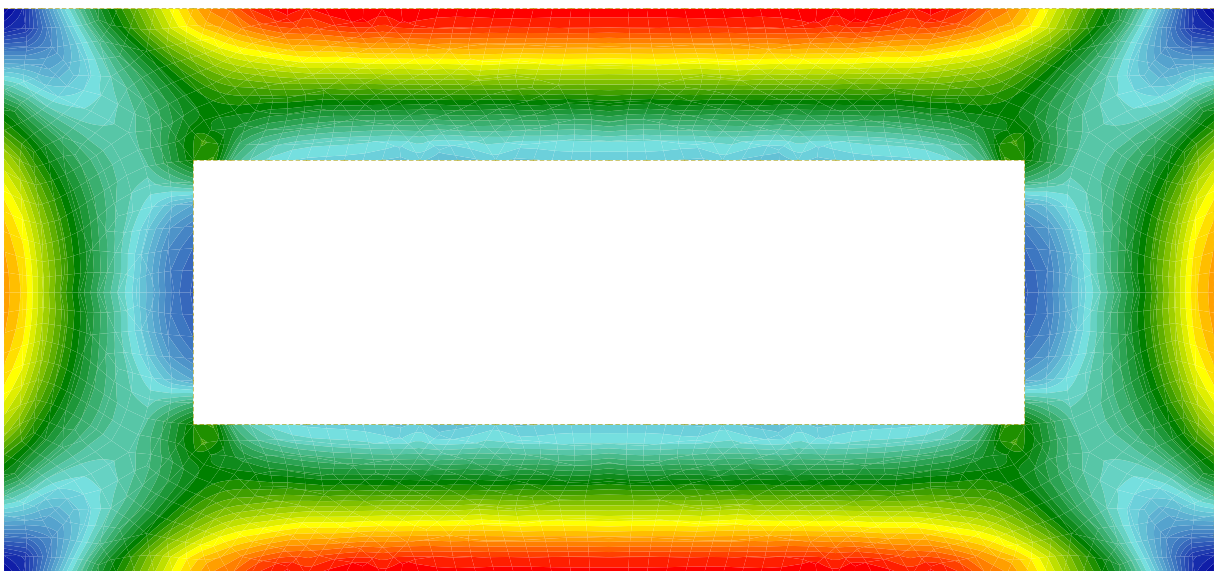

Figure 27.10: The  $\tau_t$  stresses (fill) calculated by using Finite Element Method

## 27.6 Literature

- [1] *DIN EN 1992-1-1/NA: Eurocode 2: Design of concrete structures, Part 1-1/NA: General rules and rules for buildings - German version EN 1992-1-1:2005 (D), Nationaler Anhang Deutschland - Stand Februar 2010.* CEN. 2010.
  - [3] K. Holschemacher, T. Müller, and F. Lobisch. *Bemessungshilfsmittel für Betonbauteile nach Eurocode 2 Bauingenieure.* 3rd. Ernst & Sohn, 2012.
  - [19] *DIN EN 1992-2: Eurocode 2: Design of concrete structures - Part 2, Part 2: Concrete Bridges - Design of Detailing Rules - German version EN 1992-2:2005 (D), Nationaler Anhang Deutschland - 2012.* CEN. 2012.
-



## 28 DCE-EN27: Design of Quad Elements - Layer Design and Baumann Method

### Overview

<b>Design Code Family(s):</b>	EN
<b>Design Code(s):</b>	EN 1992-1-1
<b>Module(s):</b>	BEMESS
<b>Input file(s):</b>	<a href="#">layer_design_baumann.dat</a>

### 28.1 Problem Description

The problem consists of a one-way slab, as shown in Fig. 28.1. The slab is designed for bending. This benchmark presents a procedure which uses the model based on Baumann's criteria and the Layer Design approach.

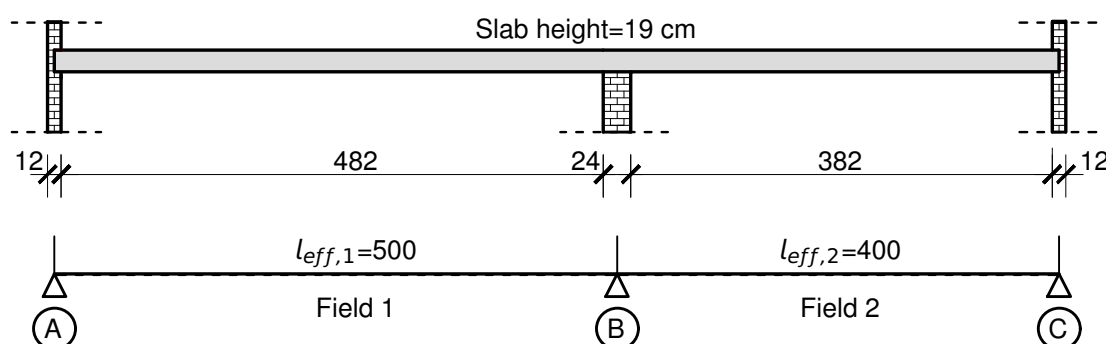

Figure 28.1: Problem Description (in cm)

### 28.2 Reference Solution

This example is concerned with the design of a one-way slab, for the ultimate limit state. The content of this problem is covered by the following parts of EN 1992-1-1:2004 [6]:

- Design stress-strain curves for concrete and reinforcement (Section 3.1.7, 3.2.7)
- Bending with or without axial force (Section 6.1)

The verification of the BEMESS results will be examined. A complete and detailed hand-calculation of the results is not possible because of described BEMESS-strategy, which should be here to exhaustive. For this reason, some results (e.g. internal forces) will be taken as outputted and further used in the hand-calculation.

The design stress-strain diagram for reinforcing steel considered in this example, consists of an inclined top branch, as presented in Fig. 28.2 and as defined in EN 1992-1-1:2004 [6] (Section 3.2.7).

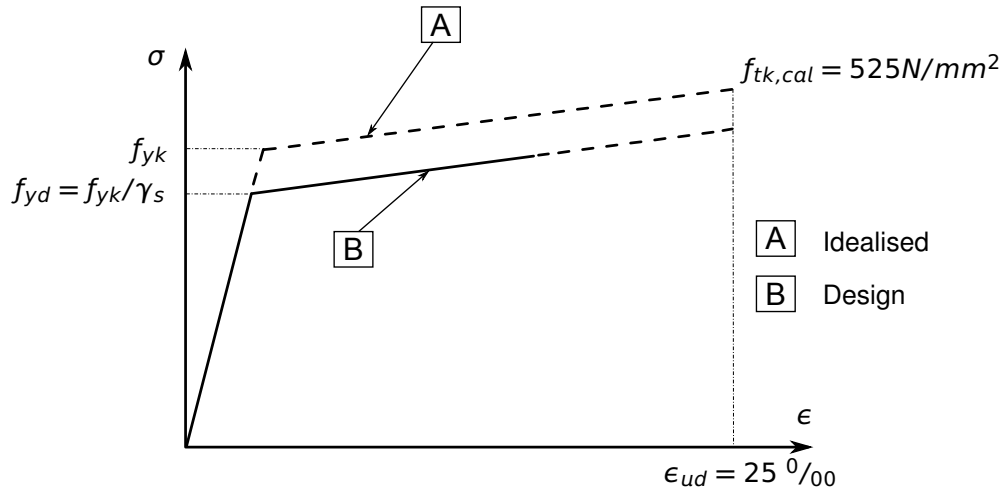

Figure 28.2: Idealised and Design Stress-Strain Diagram for Reinforcing Steel

## 28.3 Model and Results

The slab, with properties as defined in Table 28.3, is to be designed for bending moment, with respect to EN 1992-1-1:2004 [6]. The structure analysed, consists of one-way slab with a distributed load in gravity direction. The loading is presented below:

Table 28.1: Loading and actions

Title	Action	Safety Factor ULS	Value
Dead Load	G dead load	$\gamma_G = 1.35$	$g_k = 6.35 \text{ kN/m}^2$
Field 1	Q variable load	$\gamma_Q = 1.5$	$q_k = 5.0 \text{ kN/m}^2$
Field 2	Q variable load	$\gamma_Q = 1.5$	$q_k = 5.0 \text{ kN/m}^2$

$$g_d = \gamma_G \cdot g_k = 1.35 \cdot 6.35 = 8.57 \text{ kN/m}^2$$

$$q_{d,f1} = \gamma_Q \cdot q_k = 1.50 \cdot 5.00 = 7.50 \text{ kN/m}^2$$

$$q_{d,f2} = \gamma_Q \cdot q_k = 1.50 \cdot 5.00 = 7.50 \text{ kN/m}^2$$

LC 1001 →  $g_d + q_d$  in Field 1+2

LC 1002 →  $g_d + q_{d,f1}$  in Field 1

LC 1003 →  $g_d + q_{d,f2}$  in Field 2

Table 28.2: Internal forces

Loadcase	$m_{Ed,B}$	$m_{Ed,F1}$	$m_{Ed,F2}$	$V_{Ed,A}$	$V_{Ed,B,l}$	$V_{Ed,B,r}$	$V_{Ed,C}$
LC 1001	-37.16	31.00	14.40	30.00	-46.80	41.00	-20.00
LC 1002	-35.20	33.60	4.03	31.30	-45.40	25.10	-7.49
LC 1003	-28.90	14.10	19.09	14.70	-26.30	37.70	-23.20



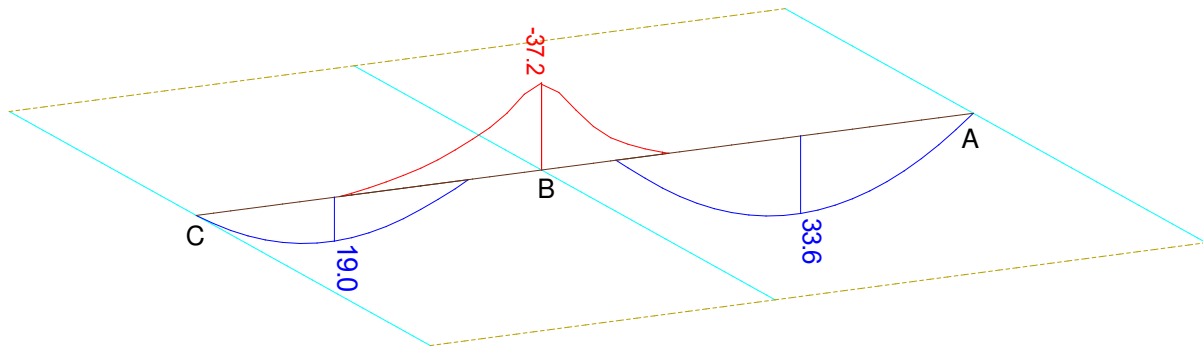

Figure 28.3:  $m_{Ed}$  envelope in  $kNm/m^2$

Table 28.3: Model Properties

Material Properties	Geometric Properties	Loading
C 20/25	$h = 19 \text{ cm}$	$g_d = 8.57 \text{ kN/m}^2$
B 500B, B 500A	$c_{nom} = 20 \text{ mm}$	$q_{d,f1} = 7.50 \text{ kN/m}^2$
	$d_1 = 3.0 \text{ cm}$	$q_{d,f2} = 7.50 \text{ kN/m}^2$
	Exposition class XC1	

The system with its loading are shown in Fig. 28.4-28.9. The reference calculation steps are presented in the next section and the results are given in Table 28.4.

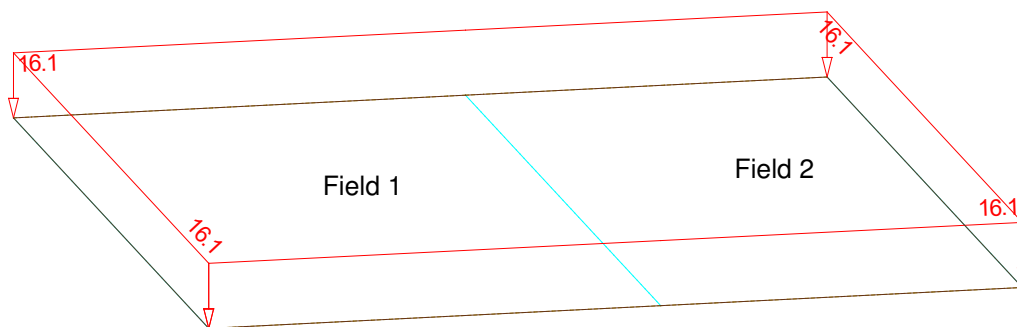

Figure 28.4: Loadcase 1001

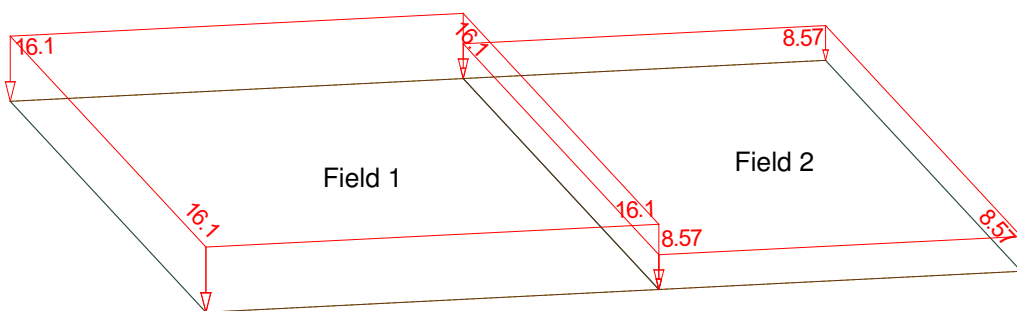

Figure 28.5: Loadcase 1002

**QUAD 10026 over Support B:**

**Required Reinforcements acc. to EN 1992-1-1:2004**

Grp	Element	LC	t [m]	asu [cm <sup>2</sup> /m]	asu2 [cm <sup>2</sup> /m]	asu3 [cm <sup>2</sup> /m]	as1 [cm <sup>2</sup> /m]	as12 [cm <sup>2</sup> /m]	as13 [cm <sup>2</sup> /m]	supp [-]	shear [-]	ass [cm <sup>2</sup> /m <sup>2</sup> ]
1	10026	1001	0.190	5.57	1.14					0.00	1	
Grp	primary group number					asu2	Cross reinforcements (2nd layer)		Top			
Element	element number					asu3	Third reinforcements		Top			
LC	load case					as1	Principal reinforcements (1st layer)		Bottom			
t	plate thickness					as12	Cross reinforcements (2nd layer)		Bottom			
asu	Principal reinforcements (1st layer) Top					as13	Third reinforcements		Bottom			
supp	reduction factor for the shear force near supports, punc=point in punching zone -> punching shear design											
shear	shear zone: 1=0k, punc=punching area, 1s=asu/l increased for shear, 1d=for punching, 2=required ass, 2m=minimum shear reinf.											
ass	Shear reinforcement											

 Figure 28.6: Layer Design - Quad 10026, Loadcase 1001,  $a_{st} = 5.57 \text{ cm}^2/\text{m}$ 
**QUAD 10726 in Field 1:**
**Required Reinforcements acc. to EN 1992-1-1:2004**

Grp	Element	LC	t [m]	asu [cm <sup>2</sup> /m]	asu2 [cm <sup>2</sup> /m]	asu3 [cm <sup>2</sup> /m]	as1 [cm <sup>2</sup> /m]	as12 [cm <sup>2</sup> /m]	as13 [cm <sup>2</sup> /m]	supp [-]	shear [-]	ass [cm <sup>2</sup> /m <sup>2</sup> ]
1	10726	1002	0.190				4.94	0.97			1	
Grp	primary group number					asu2	Cross reinforcements (2nd layer)		Top			
Element	element number					asu3	Third reinforcements		Top			
LC	load case					as1	Principal reinforcements (1st layer)		Bottom			
t	plate thickness					as12	Cross reinforcements (2nd layer)		Bottom			
asu	Principal reinforcements (1st layer) Top					as13	Third reinforcements		Bottom			
supp	reduction factor for the shear force near supports, punc=point in punching zone -> punching shear design											
shear	shear zone: 1=0k, punc=punching area, 1s=asu/l increased for shear, 1d=for punching, 2=required ass, 2m=minimum shear reinf.											
ass	Shear reinforcement											

 Figure 28.7: Layer Design - Quad 10726, Loadcase 1002,  $a_{st} = 4.94 \text{ cm}^2/\text{m}$ 
**QUAD 80376 in Field 2:**
**Required Reinforcements acc. to EN 1992-1-1:2004**

Grp	Element	LC	t [m]	asu [cm <sup>2</sup> /m]	asu2 [cm <sup>2</sup> /m]	asu3 [cm <sup>2</sup> /m]	as1 [cm <sup>2</sup> /m]	as12 [cm <sup>2</sup> /m]	as13 [cm <sup>2</sup> /m]	supp [-]	shear [-]	ass [cm <sup>2</sup> /m <sup>2</sup> ]
8	80376	1003	0.190				2.76	0.57			1	
Grp	primary group number					asu2	Cross reinforcements (2nd layer)		Top			
Element	element number					asu3	Third reinforcements		Top			
LC	load case					as1	Principal reinforcements (1st layer)		Bottom			
t	plate thickness					as12	Cross reinforcements (2nd layer)		Bottom			
asu	Principal reinforcements (1st layer) Top					as13	Third reinforcements		Bottom			
supp	reduction factor for the shear force near supports, punc=point in punching zone -> punching shear design											
shear	shear zone: 1=0k, punc=punching area, 1s=asu/l increased for shear, 1d=for punching, 2=required ass, 2m=minimum shear reinf.											
ass	Shear reinforcement											

 Figure 28.8: Layer Design - Quad 80376, Loadcase 1003,  $a_{st} = 2.76 \text{ cm}^2/\text{m}$ 

Figure 28.9: Loadcase 1003

Table 28.4: Results  $a_s$  [ $cm^2/m$ ]

Quad	SOFiSTiK		Reference	
	Baumann	Layer Design	Baumann	Tables
Support B (QUAD 10026)	5.52	5.58	5.38	5.45
Field 1 (QUAD 10726)	4.95	4.97	4.88	4.88
Field 2 (QUAD 80376)	2.65	2.81	2.70	2.70

## 28.4 Design Process<sup>1</sup>

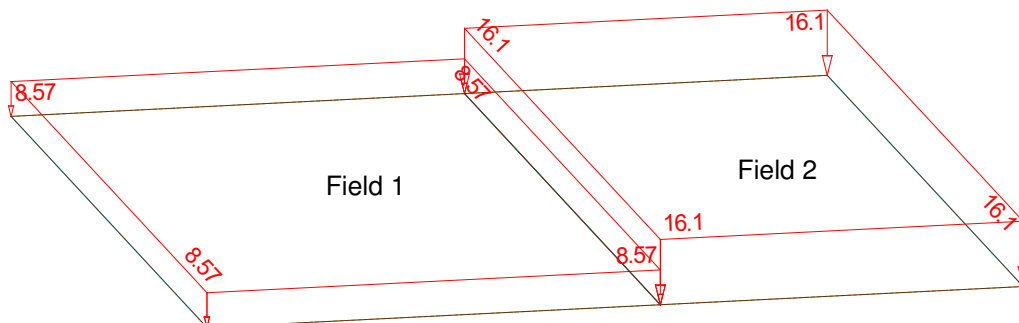
### Design with respect to EN 1992-1-1:2004 [6]:<sup>2</sup>

Material:

Concrete:  $\gamma_c = 1.50$

Steel:  $\gamma_s = 1.15$

$f_{ck} = 20 \text{ MPa}$

$f_{cd} = a_{cc} \cdot f_{ck} / \gamma_c = 1.00 \cdot 20 / 1.50 = 13.33 \text{ MPa}$

$f_{yk} = 500 \text{ MPa}$

$f_{yd} = f_{yk} / \gamma_s = 500 / 1.15 = 434.78 \text{ MPa}$

$\sigma_{sd} = 456.52 \text{ MPa}$

2.4.2.4: (1), Tab. 2.1N: Partial factors for materials for ultimate limit states

Tab. 3.1: Strength and deformation characteristics for concrete

3.1.6: Eq. (3.15):  $a_{cc} = 1.00$  considering long term effects

3.2.2: (3)P: yield strength  $f_{yk} = 500 \text{ MPa}$

3.2.7: (2), Fig. 3.8

### 1. DESIGN BY USING TABLES

To make the example more simple, the slab will be designed only for the maximum and minimum moment  $m_{Ed}$  (Field 1, Field 2 and over the middle support). The reduction of the moment over the middle support will be neglected in this example.

- Design  $m_{Ed}$  over the middle support (QUAD 10026):

$m_{Ed,B} = (m_{Ed,B,1001}, m_{Ed,B,1002}, m_{Ed,B,1003})$

$m_{Ed,B} = \max(-37.16, -35.20, -28.90) = -37.16 \text{ kNm/m}$

Calculating the  $\mu$  value:

$$\mu_{Eds} = \frac{|m_{Ed,B,Red}|}{b \cdot d^2 \cdot f_{cd}}$$

$$\mu_{Eds} = \frac{37.16 \cdot 10^{-3}}{1.0 \cdot 0.16^2 \cdot 13.33}$$

$$\mu_{Eds} = 0.1089$$

From tables:

$\mu$	$\omega$	$\xi$	$\zeta$	$\sigma_{sd}$ [MPa]
0.108867	0.11575	0.14298	0.940522	452.69

$$a_{s,req} = \omega \cdot b \cdot d \cdot f_{cd} \cdot \frac{1}{\sigma_{sd}}$$

$$a_{s,req} = 0.11576 \cdot 1.00 \cdot 0.16 \cdot 13.33 \cdot \frac{1}{452.70}$$

$$a_{s,req} = 5.45 \text{ cm}^2/\text{m}$$

- Design  $m_{Ed}$  over in Field 1 (QUAD 10726):

<sup>1</sup>The tools used in the design process are based on steel stress-strain diagrams, as defined in [1] 3.2.7:(2), Fig. 3.8, which can be seen in Fig. 28.2.

<sup>2</sup>The sections mentioned in the margins refer to EN 1992-1-1:2004 [6], unless otherwise specified.

$$m_{Ed,t1} = (m_{Ed,f1,1001}, m_{Ed,f1,1002}, m_{Ed,f1,1003})$$

$$m_{Ed,t1} = \max(31.00, 33.69, 14.10) = 33.69 \text{ kNm/m}$$

Calculating the  $\mu$  value:

$$\mu_{Eds} = \frac{|m_{Ed,B,Red}|}{b \cdot d^2 \cdot f_{cd}}$$

$$\mu_{Eds} = \frac{33.69 \cdot 10^{-3}}{1.0 \cdot 0.16^2 \cdot 13.33}$$

$$\mu_{Eds} = 0.0987$$

From tables:

$\mu$	$\omega$	$\xi$	$\zeta$	$\sigma_{sd}$ [MPa]
0.0987	0.10429	0.12882	0.9464	455.25

$$a_{s,req} = \omega \cdot b \cdot d \cdot f_{cd} \cdot \frac{1}{\sigma_{sd}}$$

$$a_{s,req} = 0.10429 \cdot 1.00 \cdot 0.16 \cdot 13.33 \cdot \frac{1}{455.25}$$

$$a_{s,req} = 4.88 \text{ cm}^2/m$$

- Design  $m_{Ed}$  over in Field 2 (QUAD 80376):

$$m_{Ed,t2} = (m_{Ed,f2,1001}, m_{Ed,f2,1002}, m_{Ed,f2,1003})$$

$$m_{Ed,t2} = \max(14.40, 4.03, 19.09) = 19.09 \text{ kNm/m}$$

Calculating the  $\mu$  value:

$$\mu_{Eds} = \frac{|m_{Ed,B,Red}|}{b \cdot d^2 \cdot f_{cd}}$$

$$\mu_{Eds} = \frac{19.09 \cdot 10^{-3}}{1.0 \cdot 0.16^2 \cdot 13.33}$$

$$\mu_{Eds} = 0.05593$$

From tables:

$\mu$	$\omega$	$\xi$	$\zeta$	$\sigma_{sd}$ [MPa]
0.05593	0.05774	0.08222	0.968533	456.52

$$a_{s,req} = \omega \cdot b \cdot d \cdot f_{cd} \cdot \frac{1}{\sigma_{sd}}$$

$$a_{s,req} = 0.05774 \cdot 1.00 \cdot 0.16 \cdot 13.33 \cdot \frac{1}{456.52}$$

$$a_{s,req} = 2.698 \text{ cm}^2/m$$

## 2. DESIGN BY USING THE MULTI LAYER APPROACH

The design approach in BEMESS 2018 was completely changed from

Baumann Method to an exact iteration of the strain state. This iteration of the strain state is called "Layer Design" or "Layer Approach" in SOFiSTiK. In the layer design the 6 strain parameters (3 strains  $\epsilon_x$ ,  $\epsilon_y$ ,  $\epsilon_{xy}$ ) and 3 curvatures  $k_x$ ,  $k_y$ ,  $k_{xy}$ ) are calculated iteratively to achieve equilibrium between the 6 inner forces and the 6 internal forces  $n_x$ ,  $n_y$ ,  $n_{xy}$ ,  $m_x$ ,  $m_y$  and  $m_{xy}$ . Thereby non-linear work-laws are taken into account for concrete and steel.

The iterative approach is not documented in this example, because it takes lot of effort to document all iterational steps. Therefore only the output is shown, see the output tables in Fig. 28.6, 28.7 and 28.8.

### 3. DESIGN BY USING BAUMANN METHOD

For each reinforcement layer: With the use of internal forces in local element direction, the internal forces in main direction and the accompanying angle is calculated with the following equation

$$m_{I/II} = \frac{m_{xx} + m_{yy}}{2} \pm 0.5 \cdot \sqrt{(m_{yy} - m_{xx})^2 + 4 \cdot m_{xy}^2}$$

$$\tan 2\varphi_0 = 2 \cdot \frac{m_{xy}}{m_{xx} - m_{yy}}$$

Accompanying to the main bending moments the normal forces and accompanying to the main normal forces the bending moments are calculated by transformation.

The internal lever arm is calculated separately for the internal forces in main moment direction and for the internal forces in main normal forces direction. This is done with the theory explained in the paper from Prof. Dr. Ing. Ulrich P. Schmitz [20]. The program choose the unfavorable lever arm from both results for the next analysis step lever arm  $z$  (This is why for each layer of reinforcement two lever arms are calculated within the program).

This lever arm  $z$  is used to calculate the virtual panel forces  $N_x$ ,  $N_y$ ,  $N_{xy}$  (in direction of the local element coordinate system) on each side of the finite element:

#### QUAD 10026 over Support B:

Calculating  $N_x$ :

$$N_x = \frac{n_{xx}}{2} + \frac{m_{xx}}{z}$$

$$N_x = \frac{0.00}{2} + \frac{37.16}{0.1514}$$

$$N_x = 245.442 \text{ kN/m}$$

Calculating  $N_y$ :

$$N_y = \frac{n_{yy}}{2} + \frac{m_{yy}}{z}$$

$$N_y = \frac{0.00}{2} + \frac{7.43}{0.1514}$$

$$N_y = 49.075 \text{ kN/m}$$

Calculating  $N_{xy}$ :

$$N_{xy} = \frac{n_{xy}}{2} + \frac{n_{xy}}{z}$$

$$N_{xy} = \frac{0.00}{2} + \frac{0.00}{0.1514}$$

$$N_{xy} = 0.00 \text{ kN/m}$$

The next step is the transformation of the panel forces  $N_x$ ,  $N_y$ ,  $N_{xy}$  into the main forces  $N_I$  and  $N_{II}$ :

$$N_I = \frac{N_x + N_y}{2} + 0.5 \cdot \sqrt{(N_y - N_x)^2 + 4 \cdot N_{xy}^2}$$

$$N_I = \frac{245.44 + 49.07}{2} + 0.5 \cdot \sqrt{(49.07 - 245.4)^2 + 4 \cdot 0.00^2}$$

$$N_I = 147.256 + 98.165 = 245.421$$

$$N_{II} = \frac{N_x + N_y}{2} - 0.5 \cdot \sqrt{(N_y - N_x)^2 + 4 \cdot N_{xy}^2}$$

$$N_{II} = \frac{245.44 + 49.07}{2} - 0.5 \cdot \sqrt{(49.07 - 245.4)^2 + 4 \cdot 0.00^2}$$

$$N_{II} = 147.256 - 98.165 = 49.091$$

$$\tan 2\varphi_0 = 2 \cdot \frac{N_{xy}}{N_x - N_y}$$

$$\tan 2\varphi_0 = 2 \cdot \frac{0.00}{245.442 - 49.07}$$

$$\tan 2\varphi_0 = 0.00 \rightarrow \varphi = 0$$

Required reinforcement:

$$k = \frac{N_2}{N_1}$$

$$k = \frac{49.091}{245.41} = 0.20$$

$$k \geq \tan(\alpha + \pi/4) \cdot \tan \alpha = 0$$

$$Z_x = N_I + \frac{N_I - N_{II}}{2} \cdot \sin 2\alpha \cdot (1 - \tan \alpha)$$

$$Z_x = 245.421 + \frac{245.421 - 49.091}{2} \cdot \sin 0 \cdot (1 - \tan 0)$$

$$Z_x = 245.421$$

$$a_s = \frac{Z_x}{\sigma_{sd}}$$

$$a_s = \frac{245.421}{456.52} = 5.375 \text{ cm}^2/\text{m}$$

**Field 1 (QUAD 10726):**

 Calculating  $N_x$ :

$$N_x = \frac{n_{xx}}{z} + \frac{m_{xx}}{z}$$

$$N_x = \frac{0.00}{0.1514} + \frac{33.70}{0.1514}$$

$$N_x = 222.589 \text{ kN/m}$$

 Calculating  $N_y$ :

$$N_y = \frac{n_{yy}}{z} + \frac{m_{yy}}{z}$$

$$N_y = \frac{0.00}{0.1514} + \frac{6.74}{0.1514}$$

$$N_y = 44.51 \text{ kN/m}$$

 Calculating  $N_{xy}$ :

$$N_{xy} = \frac{n_{xy}}{z} + \frac{m_{xy}}{z}$$

$$N_{xy} = \frac{0.00}{0.1514} + \frac{0.00}{0.1514}$$

$$N_{xy} = 0.00 \text{ kN/m}$$

 The next step is the transformation of the panel forces  $N_x$ ,  $N_y$ ,  $N_{xy}$  into the main forces  $N_I$  and  $N_{II}$ :

$$N_I = \frac{N_x + N_y}{2} + 0.5 \cdot \sqrt{(N_y - N_x)^2 + 4 \cdot N_{xy}^2}$$

$$N_I = \frac{222.589 + 44.51}{2} + 0.5 \cdot \sqrt{(44.51 - 222.589)^2 + 4 \cdot 0.00^2}$$

$$N_I = 133.5495 + 89.0395 = 222.589$$

$$N_{II} = \frac{N_x + N_y}{2} - 0.5 \cdot \sqrt{(N_y - N_x)^2 + 4 \cdot N_{xy}^2}$$

$$N_{II} = \frac{222.589 + 44.51}{2} - 0.5 \cdot \sqrt{(44.51 - 222.589)^2 + 4 \cdot 0.00^2}$$

$$N_{II} = 133.5495 - 89.0395 = 44.51$$

$$\tan 2\varphi_0 = 2 \cdot \frac{N_{xy}}{N_x - N_y}$$

$$\tan 2\varphi_0 = 2 \cdot \frac{0.00}{222.589 - 44.51}$$

$$\tan 2\varphi_0 = 0.00 \rightarrow \varphi = 0$$

Required reinforcement:



$$k = \frac{N_2}{N_1}$$

$$k = \frac{44.51}{222.589} = 0.199$$

$$k \geq \tan(\alpha + \pi/4) \cdot \tan \alpha = 0$$

$$Z_x = N_I + \frac{N_I - N_{II}}{2} \cdot \sin 2\alpha \cdot (1 - \tan \alpha)$$

$$Z_x = 222.589 + \frac{222.589 - 44.51}{2} \cdot \sin 0 \cdot (1 - \tan 0)$$

$$Z_x = 222.589$$

$$a_s = \frac{Z_x}{\sigma_{sd}}$$

$$a_s = \frac{222.589}{456.52} = 4.875 \text{ cm}^2/\text{m}$$

### Field 2 (QUAD 80376):

Calculating  $N_x$ :

$$N_x = \frac{n_{xx}}{z} + \frac{m_{xx}}{z}$$

$$N_x = \frac{0.00}{0.1514} + \frac{19.09}{0.1549}$$

$$N_x = 123.24 \text{ kN/m}$$

Calculating  $N_y$ :

$$N_y = \frac{n_{yy}}{z} + \frac{m_{yy}}{z}$$

$$N_y = \frac{0.00}{0.1549} + \frac{3.86}{0.1549}$$

$$N_y = 24.91 \text{ kN/m}$$

Calculating  $N_{xy}$ :

$$N_{xy} = \frac{n_{xy}}{z} + \frac{m_{xy}}{z}$$

$$N_{xy} = \frac{0.00}{0.1549} + \frac{0.00}{0.1549}$$

$$N_{xy} = 0.00 \text{ kN/m}$$

The next step is the transformation of the panel forces  $N_x$ ,  $N_y$ ,  $N_{xy}$  into the main forces  $N_I$  and  $N_{II}$ :

$$N_I = \frac{N_x + N_y}{2} + 0.5 \cdot \sqrt{(N_y - N_x)^2 + 4 \cdot N_{xy}^2}$$

$$N_I = \frac{123.24 + 24.91}{2} + 0.5 \cdot \sqrt{(24.91 - 123.24)^2 + 4 \cdot 0.00^2}$$

$$N_I = 74.075 + 49.165 = 123.24$$

$$N_{II} = \frac{N_x + N_y}{2} - 0.5 \cdot \sqrt{(N_y - N_x)^2 + 4 \cdot N_{xy}^2}$$

$$N_{II} = \frac{123.24 + 24.91}{2} - 0.5 \cdot \sqrt{(24.91 - 123.24)^2 + 4 \cdot 0.00^2}$$

$$N_{II} = 74.075 - 49.165 = 24.91$$

$$\tan 2\varphi_0 = 2 \cdot \frac{N_{xy}}{N_x - N_y}$$

$$\tan 2\varphi_0 = 2 \cdot \frac{0.00}{123.24 - 24.91}$$

$$\tan 2\varphi_0 = 0.00 \rightarrow \varphi = 0$$

Required reinforcement:

$$k = \frac{N_2}{N_1}$$

$$k = \frac{24.91}{123.24} = 0.202$$

$$k \geq \tan(\alpha + \pi/4) \cdot \tan \alpha = 0$$

$$Z_x = N_I + \frac{N_I - N_{II}}{2} \cdot \sin 2\alpha \cdot (1 - \tan \alpha)$$

$$Z_x = 123.24 + \frac{123.24 - 24.91}{2} \cdot \sin 0 \cdot (1 - \tan 0)$$

$$Z_x = 123.24$$

$$a_s = \frac{Z_x}{\sigma_{sd}}$$

$$a_s = \frac{123.24}{456.52} = 2.70 \text{ cm}^2/\text{m}$$

## 28.5 Conclusion

This example shows the calculation of the required reinforcement for a one-way slab under bending. It has been shown that the results are reproduced with very good accuracy.

## 28.6 Literature

- [1] *DIN EN 1992-1-1/NA: Eurocode 2: Design of concrete structures, Part 1-1/NA: General rules and rules for buildings - German version EN 1992-1-1:2005 (D), Nationaler Anhang Deutschland - Stand Februar 2010*. CEN. 2010.
  - [4] *Beispiele zur Bemessung nach Eurocode 2 - Band 1: Hochbau*. Ernst & Sohn. Deutschen Beton- und Bautechnik-Verein E.V. 2011.
  - [6] *EN 1992-1-1: Eurocode 2: Design of concrete structures, Part 1-1: General rules and rules for buildings*. CEN. 2004.
  - [20] Ulrich P. Schmitz. "Biegebemessung nach der neuen E-DIN 1045-1". In: *Bauinformatik JOURNAL* (1999), pp. 49–51.
-



## 29 DCE-EN28: Design of a T-section for bending and shear using Design Elements

### Overview

<b>Design Code Family(s):</b>	DIN
<b>Design Code(s):</b>	DIN EN 1992-1-1
<b>Module(s):</b>	DECREATOR, AQB
<b>Input file(s):</b>	<a href="#">t-beam_de.dat</a>

### 29.1 Problem Description

This section demonstrates design elements as a solution to the problem of a member modeled out of beam and quad elements; which is to be designed using a given cross section. An instance of a beam having a T-section as shown in Fig. 29.2 is considered. The beam constitutes a loaded floor slab shown in Fig. 29.1.

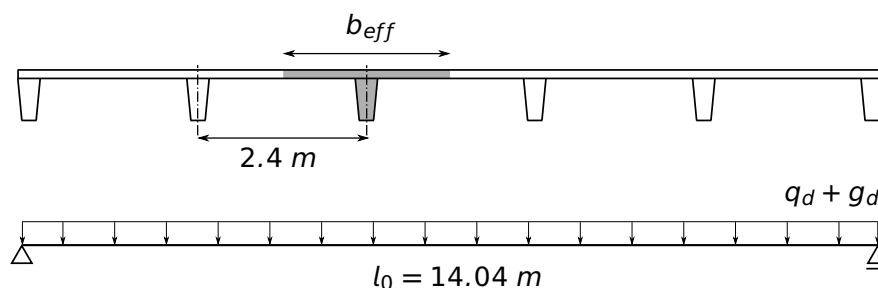

Figure 29.1: Sketch of the slab and longitudinal system of single t-beam member

### 29.2 Reference Solution

The reference inputs and results of this problem were adopted from an extended solution to a similar problem in section 7 of [4]. The standard aspects of the design procedures are covered in the following parts of the Eurocode DIN EN 1992-1-1 [6]:

- Concrete (Section 3.1)
- Reinforcing Steel (Section 3.2)
- Bending with or without axial force (Section 6.1)
- Shear (Section 6.2)

### 29.3 Model and Results

The beam member is assumed to be simply supported with out carrying normal force. It's finite element model is formed in SOFiSTiK using quad elements for the flange and an eccentrically coupled beam element for the web. The self-weight parts of the design loads are applied separately to each element. After analysis, a design element spanning the entire beam length is then defined using the program DECREATOR. The design element then integrates the stresses of the quad elements at its design

sections, and superimposes these with the corresponding forces of the eccentric beam to result in the design values of the bending moment  $M_{Ed}$  and shear force  $V_{Ed}$ .

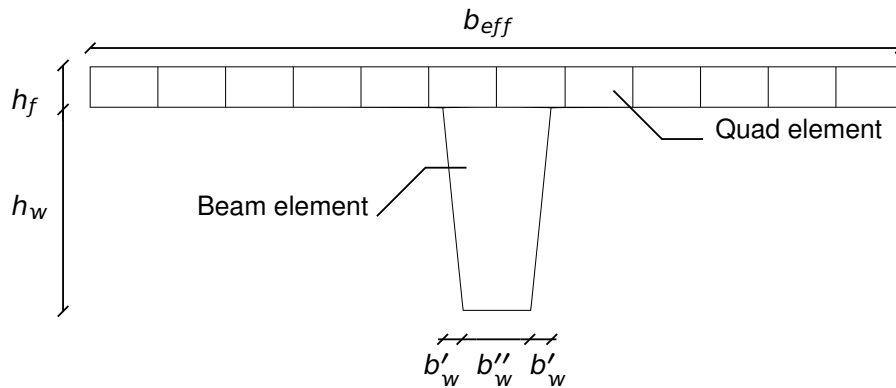

Figure 29.2: Cross sectional view of the model out of quad and beam elements

The sectional properties and loadings of the member are given in table 29.1. The analysis gives results of the individual quad and beam elements. DECREATOR is then used to integrate all forces at the explicit design sections for use in design. Since, in this model, the centroid of the chosen cross section lies on the design element, no transformation of forces from design element axis to the centroid takes place during computation. However, this full cross section will be used for design. The final analysis and design results are given in Table 29.2, the reference calculation procedures of which are presented in the following section.

Table 29.1: Model Properties

Material Properties	Geometric Properties	Loading
C 35/45	$h_w = 60.0 \text{ cm}$	$q_d = 8.85 \text{ kN/m}^2$
B 500B	$h_f = 12.0 \text{ cm}$	$g_{d,flange} = 6.41 \text{ kN/m}^2$
	$d = 62.20 \text{ cm}$	$g_{d,web} = 5.27 \text{ kN/m}$
	$b_{eff} = 240 \text{ cm}$	
	$b''_w = 20.0 \text{ cm}$	
	$b'_w = 6.0 \text{ cm}$	
	$b_w = 26.0 \text{ cm}$	

Summarized in Table 2 are the results of the reference example in [4] (Ref.-2), those obtained based on design tables (Ref.-1) as presented in the next section, and those from SOFiSTiK computations. For simplification purposes the reference example uses rough approximate procedures in obtaining reinforcement areas, while the hand calculation and the SOFiSTiK results come from iterative approximations and are as close to the exact requirements as possible.

In this regard, in calculating the reinforcement area in Ref.-2, the full thickness of the flange was assumed to roughly approximate the compressive zone. The moment arm is thereby reduced and hence it resulted in a larger reinforcement area. In a similar manner, the shear reinforcements in Ref.-2 are larger since the example selects a suitable reinforcement diameter and spacing in advance to compute the area,

which is more than the required amount.

Table 29.2: Results

	SOF.	Ref.-1	Ref.-2
$M_{Ed}$ [kNm]	1085.85	1086.0	1086.0
$A_{s,req} / s$ [cm <sup>2</sup> /m]	39.42	41.34	44.60
$V_{Ed}$ [kN] for $x = 13.680$ m	269.56	272.0	272.0
$A_{s,req} / s$ [cm <sup>2</sup> /m] for $x = 13.680$ m	8.42	9.3	15.71

## 29.4 Design Process

### Design with respect to DIN EN 1992-1-1 [6]:<sup>1</sup>

Design of the T-beam for bending and shear are carried out using the T-cross section, as shown in figure 29.3. References on the side margins can be further reviewed for notations and explanations.

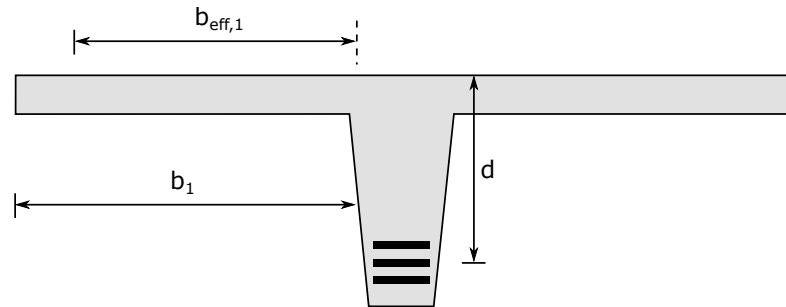

Figure 29.3: Full cross-section used for design

Material partial factors and design strengths:

(NDP) 2.4.2.4: (1), Tab. 2.1DE: Partial factors for materials

Concrete:  $\gamma_c = 1.50$

Steel:  $\gamma_s = 1.15$

Tab. 3.1: Strength for concrete

3.1.6: (1)P, Eq. (3.15):  $\alpha_{cc} = 0.85$  considering long term effects

3.2.2: (3)P: yield strength  $f_{yk} = 500$  MPa

$f_{ck} = 35$  MPa

$f_{cd} = \alpha_{cc} \cdot f_{ck} / \gamma_c = 0.85 \cdot 35 / 1.5 = 19.83$  MPa

$f_{yk} = 500$  MPa

$f_{yd} = f_{yk} / \gamma_s = 500 / 1.15 = 434.78$  MPa

### Design for bending:

Design section at:  $x = l_0 / 2.0 = 14.40 / 2.0 = 7.20$  m

Design bending moment:  $M_{Ed} = 1086.0$  kNm

Effective width of flange  $b_{eff}$  :

5.3.2.1: (3) Eq. (5.7) and Fig. (5.3) for notations

5.3.2.1: (3) Eq. (5.7a)

$$b_{eff} = \sum b_{eff,i} + b_w \leq b$$

$$b_{eff,i} = 0.2 \cdot b_i + 0.1 \cdot l_0 \leq 0.2 \cdot l_0$$

$$b_i = 0.5 \cdot (b_{eff} - b_w)$$

$$b_{1,2} = 0.5 \cdot (2.4 - 0.26) = 1.07$$
 m

$$b_{eff1,2} = 0.2 \cdot 1.07 + 0.1 \cdot 14.40 = 1.65$$
 m  $\leq 0.2 \cdot l_0$

But,  $b_{eff1,2} > b_{1,2} = 1.07$  m

$$\therefore b_{eff} = 2 \cdot 1.07 + 0.26 = 2.40$$
 m

<sup>1</sup>The sections mentioned in the margins refer to DIN EN 1992-1-1 (German National Annex) [6], unless otherwise specified



Reinforcement depth  $d$ , for three layers of re-bars with  $\phi 25$ :

$$c_{nom} = c_{min} + \Delta c_{dev} = 25 + 10 = 35 \text{ mm}$$

$$d = h - c_{nom} - 2.5 \cdot \phi$$

$$d = 720 - 35 - 2.5 \cdot 25 = 620 \text{ mm}$$

Design cross-section:

$$b_{eff}/h_f/b_w/h/d = 2.40/0.12/0.26/0.72/0.62 \text{ m}$$

Using design table for T-beams:

$$\mu_{Eds} = \frac{M_{Eds}}{b_{eff} \cdot d^2 \cdot f_{cd}} = \frac{1086.0}{2.4 \cdot 0.62^2 \cdot 19.83} = 0.0594$$

For  $\mu_{Eds} = 0.0594$  and  $b_{eff}/b_w = 9.23$ ,

table 9.4 of [3] results in  $\omega_1 = 0.0609$

Required bottom-reinforcement for bending at the design section:

$$A_{s1} = \frac{1}{f_{yd}} (\omega_1 \cdot b_{eff} \cdot d \cdot f_{cd}) = 41.34 \text{ cm}^2$$

### Design for Shear:

Design section at:  $x = 0.5 \cdot 0.2 + 0.62 = 0.72 \text{ m}$

Design shear force:  $V_{Rd,s} = 272.0 \text{ kN}$

Vertical reinforcement from shear resistance:

$$V_{Rd,s} = (A_{sw}/S) \cdot z \cdot f_{ywd} \cdot \cot \theta$$

$$(A_{sw}/S) = \frac{V_{Rd,s}}{z \cdot f_{ywd} \cdot \cot \theta}$$

$$\cot \theta = 1.2$$

$$z = 0.9d = 0.9 \cdot 0.62 = 0.558 \text{ m}$$

Required total shear reinforcement at the design section:

$$(A_{sw}/S) = \frac{272.0}{0.558 \cdot 434.78 \cdot 1.2} = 9.33 \text{ cm}^2/\text{m}$$

4.4.1.1:(2) Eq. (4.1) Nominal concrete cover

Assumptions: Stirrups  $\phi_{st} \leq 10 \text{ mm}$   
 Longitudinal reinforcement:  $\phi 25$  in 3-layers  
 Reinforcement and spacing:  $(3 + 2)/2 = 2.5$

$\mu_s$  - Table for T-beams (Tab. 9.4) [3]

Equation from table 9.4 in [3]

Distance from center of elastomer support with thickness  $b=200 \text{ mm}$  [4]

6.2.3:(3) Eq. (6.8)

6.2.3:(2), simplified for pure bending [4]

## 29.5 Conclusion

It has been demonstrated in this example that, using Design Elements in SOFiSTiK, a structural member modeled out of different finite element types can be designed with a unifying full cross section. The critical internal forces were well approximated and reasonable design results were obtained.

## 29.6 Literature

- [3] K. Holschemacher, T. Müller, and F. Lobisch. *Bemessungshilfsmittel für Betonbauteile nach Eurocode 2 Bauingenieure*. 3rd. Ernst & Sohn, 2012.
  - [4] *Beispiele zur Bemessung nach Eurocode 2 - Band 1: Hochbau*. Ernst & Sohn. Deutschen Beton- und Bautechnik-Verein E.V. 2011.
  - [6] *EN 1992-1-1: Eurocode 2: Design of concrete structures, Part 1-1: General rules and rules for buildings*. CEN. 2004.
-

## 30 DCE-EN29: Design of restrained steel column

### Overview

<b>Design Code Family(s):</b>	DIN
<b>Design Code(s):</b>	DIN EN 1993-1-1
<b>Module(s):</b>	BDK
<b>Input file(s):</b>	<a href="#">design_schneider_example_8-41.dat</a>

### 30.1 Problem Description

The problem consists of a simply supported beam with a steel HEA 200 section which is restrained in the middle of the length. The column is subjected to compression and bending as shown in Fig. 30.1.

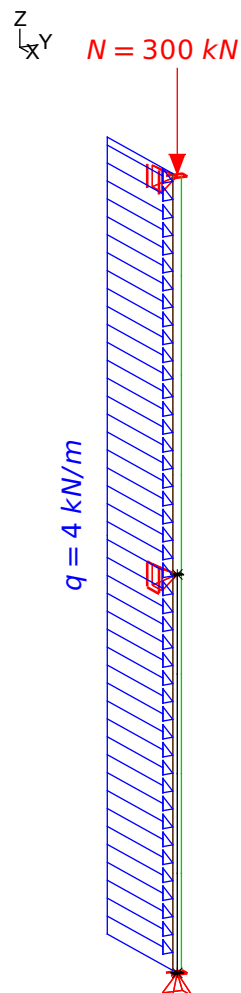

Figure 30.1: Problem Description

## 30.2 Reference Solution

This example is concerned with the buckling resistance of steel members. It deals with the spatial behavior of the beam and the occurrence of lateral torsional buckling as a potential mode of failure. The content of this problem is covered by the following parts of DIN EN 1993-1-1:2005 [21]:

- Structural steel (Section 3.2 )
- Classification of cross-sections (Section 5.5)
- Buckling resistance of members (Section 6.3)
- Method 2: Interaction factors  $k_{ij}$  for interaction formula in 6.3.3(4) (Annex B)

## 30.3 Model and Results

Table 30.1: Model Properties

Material Properties	Cross-Section Properties	Geometric Properties	Loading
<i>S</i> 235	$h = 190 \text{ mm}$	$H = 8.0 \text{ m}$	$q = 4.00 \text{ kN/m}$
$E = 210000 \text{ N/mm}^2$	$b = 200 \text{ mm}$		
$f_y = 235 \text{ N/mm}^2$	$c = 32 \text{ mm}$		
$\nu = 0.3$	$r = 18 \text{ mm}$		
$G = 81000 \text{ N/mm}^2$	$t_f = 10 \text{ mm}$		
$\gamma_{M0} = 1.0$	$t_w = 6.5 \text{ mm}$		
$\gamma_{M1} = 1.1$	$A = 5308 \text{ mm}^2$		
	$i_y = 82.8 \text{ mm}$		
	$i_z = 49.8 \text{ mm}$		
	$I_y = 3690 \text{ cm}^4$		
	$I_z = 1340 \text{ cm}^4$		
	$I_t = 21 \text{ cm}^4$		

Table 30.2: Results

	SOF.	Ref. [8]
$L_{cr,y} [m]$	8.00	8.00
$L_{cr,z} [m]$	4.00	4.00
$N_{pl,Rd} [kN]$	1265.4	1264.3
$M_{pl,y,Rd} [kNm]$	100.96	100.90

Table 30.2: (continued)

	SOF.	Ref. [8]
$\bar{\lambda}_y$	1.029	1.029
$\bar{\lambda}_z$	0.855	0.855
$N_{cr,z}$ [kN]	1730.1	1736
$M_{cr}$ [kNm]	245.47	220.9
$\bar{\lambda}_{LT}$	0.641	0.676
$k_{yy}$	1.292	1.304
$k_{zy}$	0.935	0.936

## 30.4 Design Process<sup>1</sup>

### Design Loads:

$$N_d = 300 \text{ kN}$$

$$q = 4.0 \text{ kN/m}$$

$$M_{y,d} = q \cdot L^2/8 = 4.0 \cdot 8^2/8 = 32.0 \text{ kNm}$$

$$M_{z,d} = 0$$

### Buckling lengths:

$$L_{cr,y} = 8.00 \text{ m}$$

$$L_{cr,z} = 4.00 \text{ m}$$

$$\xi = 1.35$$

### Characteristic values:

$$N_{Rk} = N_{pl,Rd} = 1264.3 \text{ kN}$$

$$M_{y,Rk} = M_{pl,y,Rd} = 100.9 \text{ kNm}$$

$I_z$  - second moment of area

$$I_z = 1340 \text{ cm}^4$$

$I_w$  - warping resistance

$$I_w = 108000 \text{ cm}^6$$

$I_t$  - torsional moment of inertia

$$I_t = 21.0 \text{ cm}^4$$

$$i_y = 8.28 \text{ cm}$$

$$i_z = 4.98 \text{ cm}$$

$$z_p = -9.5 \text{ cm}$$

### Buckling around the y-y axis:

$$\bar{\lambda}_y = 800/(8.28 \cdot 93.9) = 1.029 \rightarrow \chi = 0.58 \text{ (Curve b)}$$

$$\bar{\lambda}_z = 400/(4.98 \cdot 93.9) = 0.855 \rightarrow \chi = 0.63 \text{ (Curve c)}$$

### Critical loading:

$N_{cr}$  - elastic critical force for the relevant buckling mode based on the gross cross sectional properties

$$N_{cr,z} = \pi^2 \cdot 21000 \cdot 1340/400^2 = 1736 \text{ kN}$$

$$c^2 = (108000 + 0.039 \cdot 400^2 \cdot 21.0)/1340 = 178.4 \text{ cm}^2$$

$M_{cr}$  - elastic critical moment for lateral-torsional buckling

$$M_{cr} = 1.35 \cdot 1736 \cdot \left[ \sqrt{178.4 + 0.25 \cdot 9.5^2} + 0.5 \cdot (-9.5) \right] \cdot 10^2$$

$$M_{cr} = 220.9 \text{ kNm}$$

<sup>1</sup>The sections mentioned in the margins refer to DIN EN 1993-1-1:2005 [21] unless otherwise specified.

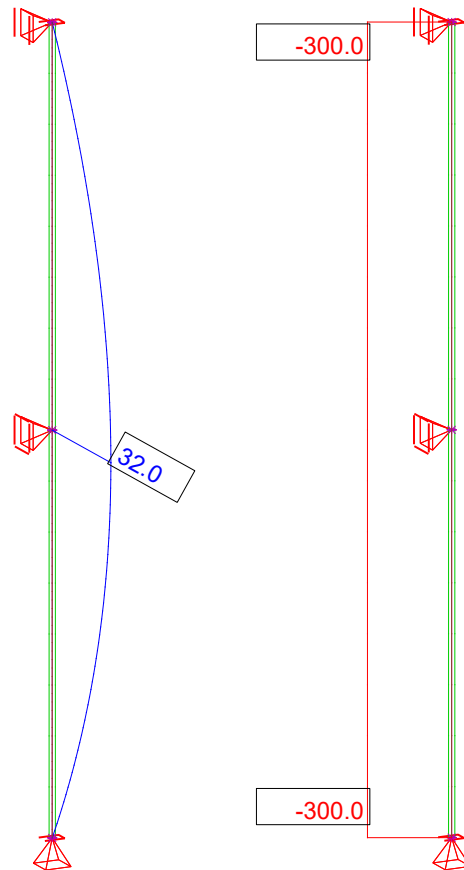
Figure 30.2: Internal forces  $M_y$  and  $N$ 

$$\bar{\lambda}_{LT} = \sqrt{100.9/220.9} = 0.676$$

$$h/b = 190/200 = 0.95 < 2.0 \rightarrow \text{Class b}$$

$$\chi_{LT} = \frac{1}{\Phi_{LT} + \sqrt{\Phi_{LT}^2 - \beta \cdot \bar{\lambda}_{LT}^2}}$$

$$\Phi_{LT} = 0.5 \cdot \left[ 1 + \alpha_{LT} \cdot (\bar{\lambda}_{LT} - \bar{\lambda}_{LT,0}) + \beta \cdot \bar{\lambda}_{LT}^2 \right]$$

$$\chi_{LT} = 0.88 < 2.188 = 1/0.676^2$$

$$M_{b,Rd} = M_{pl,y,Rd} \cdot \frac{\chi_{LT}}{f} \cdot \frac{1}{\gamma_{M1}}$$

$$f = 1 - 0.5 \cdot (1 - k_c) \cdot \left[ 1 - 2.0 \cdot (\bar{\lambda}_{LT} - 0.8)^2 \right]$$

$$f = 1 - 0.5 \cdot (1 - 0.94) \cdot \left[ 1 - 2.0 \cdot (0.676 - 0.8)^2 \right]$$

$$f = 0.972$$

$$M_{b,Rd} = 100.9 \cdot \frac{0.88}{0.972} \cdot \frac{1}{1.1}$$

$$M_{b,Rd} = 83.045 \text{ kNm}$$

**Equivalent uniform moment factors:**

$\bar{\lambda}_{LT}$  - non dimensional slenderness for lateral torsional buckling

$\chi_{LT}$  - reduction factor

$f$  - the value  $f$  may be defined in National Annex, see EC 3, §6.3.2.3(2)

$m_{b,Rd}$  - design buckling resistance moment - EC 3, §6.3.2.1, Eq. 6.55

$L_{cr,y}$  - buckling length

for  $L_{cr,y} = 8.00 \text{ m}$  :

$$\alpha_h = M_h/M_S = 0.00$$

$$\psi = 1.00$$

$$c_{my} = 0.95 + 0.05 \cdot 0.00 = 0.95$$

$L_{cr,z}$  - buckling length

for  $L_{cr,z} = 4.00 \text{ m}$  :

$$\alpha_h = M_h/M_S = 0.75$$

$$\psi = 0.00$$

$$c_{mLT} = 0.2 + 0.8 \cdot 0.75 = 0.80$$

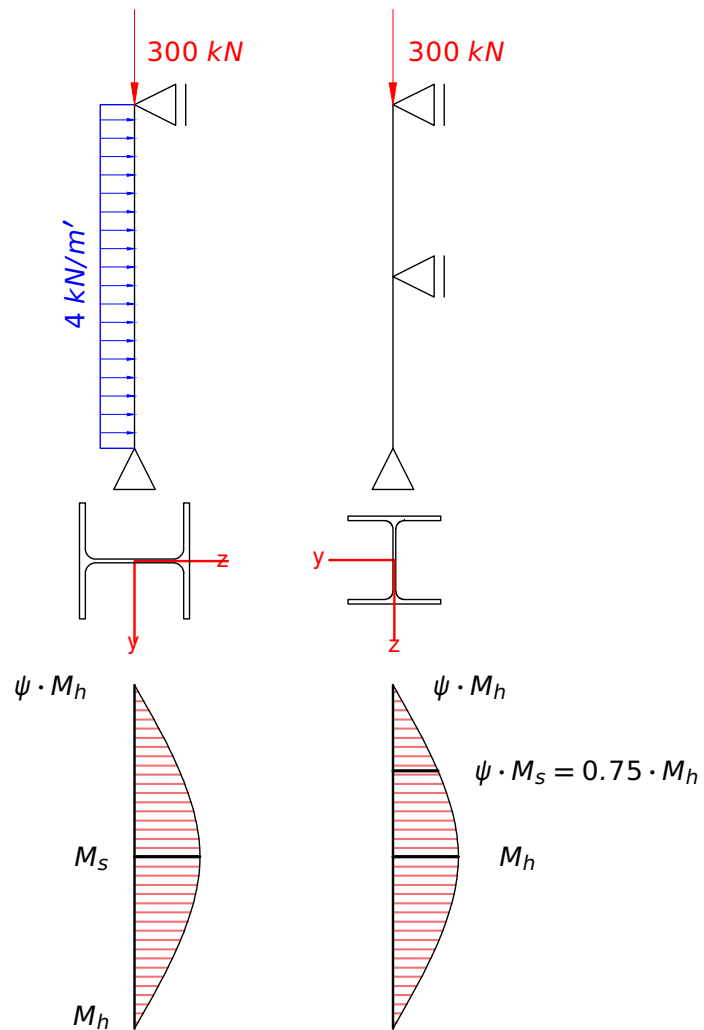

Figure 30.3: Calculating the equivalent uniform moment factors

$k_{yy}, k_{zy}$  - Annex B: Method 2, interaction factors for interaction formula in §6.3.3(4)

### Interaction factors:



$$\begin{aligned}
 k_{yy} &= 0.95 \cdot \left( 1 + 1.029 - 0.2 \right) \cdot 300 \cdot \frac{1.1}{0.580 \cdot 1264.3} \\
 &= 1.304 \\
 &\leq 0.95 \cdot \left( 1 + 0.8 \cdot 300 \cdot \frac{1.1}{0.580 \cdot 1264.3} \right) = 1.292 \\
 &\leq 1.80
 \end{aligned}$$

$$\begin{aligned}
 k_{zy} &= \left[ 1 - \frac{0.1 \cdot 0.855}{0.8 - 0.25} \cdot \frac{300 \cdot 1.1}{0.63 \cdot 1264.3} \right] = 0.936 \\
 &\geq \left[ 1 - \frac{0.1}{0.8 - 0.25} \cdot \frac{300 \cdot 1.1}{0.63 \cdot 1264.3} \right] = 0.925 \\
 &\geq 0.3 \cdot 300 \cdot \frac{1.1}{0.63 \cdot 1264.3} = 0.138
 \end{aligned}$$

**Lateral Torsional Buckling check:**

$$\frac{300}{0.58 \cdot 1264.3/1.1} + 1.292 \cdot \frac{32.0 + 0.0}{0.88 \cdot 100.9/1.1} + 0.0 = 0.96 \leq 1.0$$

$$\frac{300}{0.63 \cdot 1264.3/1.1} + 0.936 \cdot \frac{32.0 + 0.0}{0.88 \cdot 100.9/1.1} + 0.0 = 0.79 \leq 1.0$$

Lateral Torsional Buckling, §6.3.3, Eq. 6.61 and 6.62

## 30.5 Conclusion

This example shows the check for lateral torsional buckling of steel members. The small deviations that occur in some results come from the fact that there are some small differences in the sectional values and elastic critical loadings ( $M_{cr}$ ,  $N_{cr}$ ). Therefore, these deviations are of no interest for the specific verification process. In conclusion, it has been shown that the results are reproduced with excellent accuracy.

## 30.6 Literature

- [8] Schneider. *Bautabellen für Ingenieure*. 21th. Bundesanzeiger Verlag, 2014.
  - [21] *DIN EN 1993-1-1:2005 Eurocode 3: Design of steel structures, Part 1-1: General rules and rules for buildings - Deutsche Fassung EN 1993-1-1:2005 + AC:2009*. CEN. 2010.
-

## 31 DCE-EN30: Steel column with a class 4 cross-section

### Overview

<b>Design Code Family(s):</b>	EN
<b>Design Code(s):</b>	EN 1993-1-1
<b>Module(s):</b>	BDK, AQB, AQUA
<b>Input file(s):</b>	<a href="#">scl_4_sig_neff.dat</a> , <a href="#">scl_4_iterative.dat</a>

### 31.1 Problem Description

The problem consists of a simply supported beam with a box cross-section shown in Fig. 31.1. The design element should be verified against uniform compression as shown in Fig. 31.2.

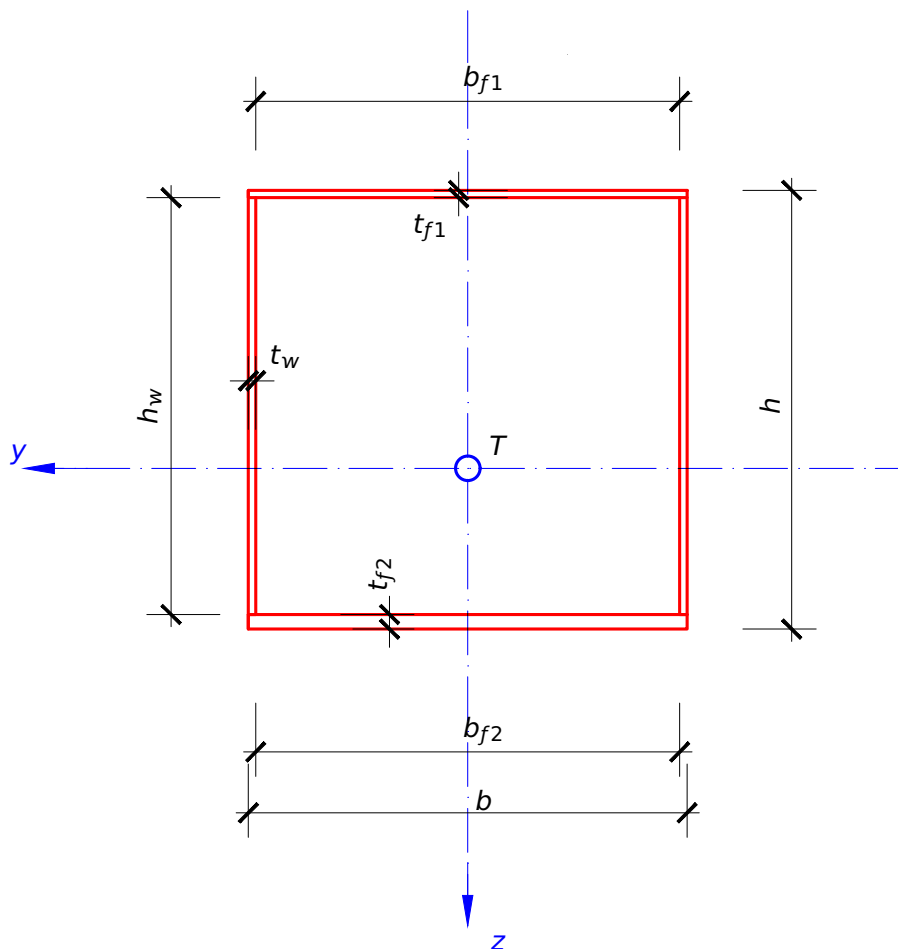
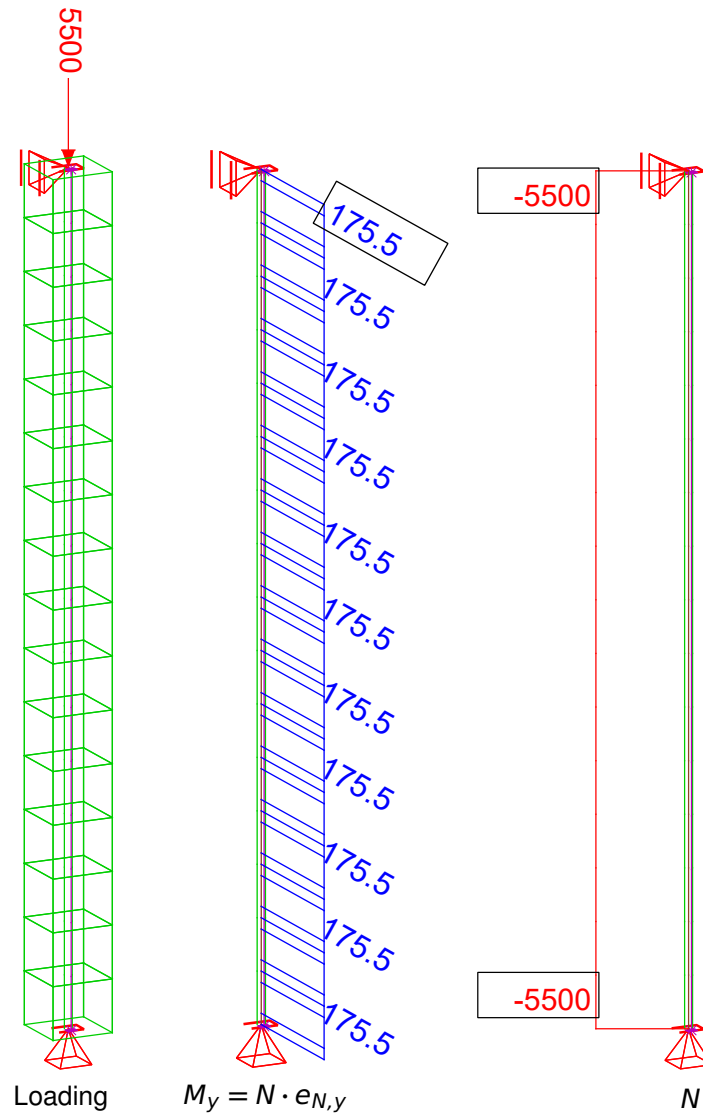

Figure 31.1: Geometry of box cross-section

This benchmark example is used to verify and compare the SOFiSTiK results with the ECCS reference example [22].

 Figure 31.2: Model, loadings and the internal forces  $M_y$ ,  $N$ 

## 31.2 Reference Solution

This example is concerned with the cross-section and buckling resistance of steel members. It deals with the spatial behavior of the beam and the occurrence of lateral torsional buckling as a potential mode of failure. The content of this problem is covered by the following parts of EN 1993-1-1:2005 [7]:

- Structural steel (Section 3.2 )
- Classification of cross-sections (Section 5.5)
- Buckling resistance of members (Section 6.3)
- Method 2: Interaction factors  $k_{ij}$  for interaction formula in 6.3.3(4) (Annex B)

and parts of EN 1993-1-5:2006 [23]

- Effective cross section (Section 4.3 )

### 31.3 Model and Results

Table 31.1: Model Properties

Material Properties	Cross-Section Properties	Geometric Properties	Loading
$S\ 275$	$h = 600\ mm$	$H = 4.0\ m$	$N = 5500\ kN$
$E = 210000\ N/mm^2$	$b = 600\ mm$		
$f_y = 275\ N/mm^2$	$t_{f1} = 10\ mm$		
$\nu = 0.3$	$t_{f2} = 20\ mm$		
$G = 81000\ N/mm^2$	$t_w = 10\ mm$		
$\gamma_{M0} = 1.0$	$A = 29400\ mm^2$		
$\gamma_{M1} = 1.0$	$I_y = 174800.0\ cm^4$		
	$I_z = 153200.0\ cm^4$		

Table 31.2: Results

	SOF. (Iterative)	SOF. (SIG NEFF)	Ref. [22] <sup>1</sup>
$A_{eff}\ [cm^2]$	275.4	250.2	247.78
$I_{y,eff}\ [cm^4]$	1556000	152400	154000.0
$e_{N,y}\ [mm]$	38.03	28.20	30.1
$b_{f1,eff}\ [mm]$	131.1 ( $\rho = 0.77$ )	151.3	159.5
$b_{w2,eff}\ [mm]$	100.8 ( $\rho = 0.82$ )	143.24	151.3
$b_{w4,eff}\ [mm]$	100.8 ( $\rho = 0.82$ )	143.24	151.3
$Tot_{utilisation}$	-	0.94	0.95
$\chi$	1.0	1.0	1.0
$\bar{\lambda}_y$	0.183	0.174	0.173
$\bar{\lambda}_z$	0.195	0.186	0.185
$k_{yy}$	1.080	1.084	1.084
$k_{zy}$	0.864	0.867	0.867
$nm - y$	0.934	0.952	0.973
$nm - z$	0.893	0.921	0.940

<sup>2</sup>The buckling resistance check has been calculated using hand calculation (SOFiSTiK).

## 31.4 Design Process<sup>3</sup>

### Design Loads

$$N_{Ed} = 5500 \text{ kN}$$

### 1. CROSS-SECTION RESISTANCE

**STEP 1:** Cross-Section class check

$$b_{f1} = b_{f2} = b - 2 \cdot t_w = 600 - 2 \cdot 10 = 580 \text{ mm}$$

$$h_w = h - t_{f1} - t_{f2} = 600 - 10 - 20 = 570 \text{ mm}$$

Upper flange (compression):

$$\varepsilon = \sqrt{\frac{235}{f_y}} = \sqrt{\frac{235}{275}} = 0.924$$

$$\frac{b_{f1}}{t_{f1}} = \frac{580}{10} = 58.0 > 42 \cdot \varepsilon = 42 \cdot 0.924 = 38.8 \text{ (Class 4)}$$

Lower flange (compression):

$$\frac{b_{f2}}{t_{f2}} = \frac{580}{20} = 29.0 < 42 \cdot \varepsilon = 38.8 \text{ (Class 3)}$$

Class 3 - but it also fulfils requirements for Class 1 ( $33 \cdot \varepsilon$ )

Web (compression):

$$\frac{h_w}{t_w} = \frac{570}{10} = 57.0 > 42 \cdot \varepsilon = 38.8 \text{ (Class 4)}$$

The cross-section is classified as Class 4.

**STEP 2:** Calculating the effective properties under uniform axial compression

<sup>3</sup>The sections mentioned in the margins refer to DIN EN 1993-1-1:2005 [21] unless otherwise specified.

Cross-section classification, EN 1993-1-1, Table 5.2

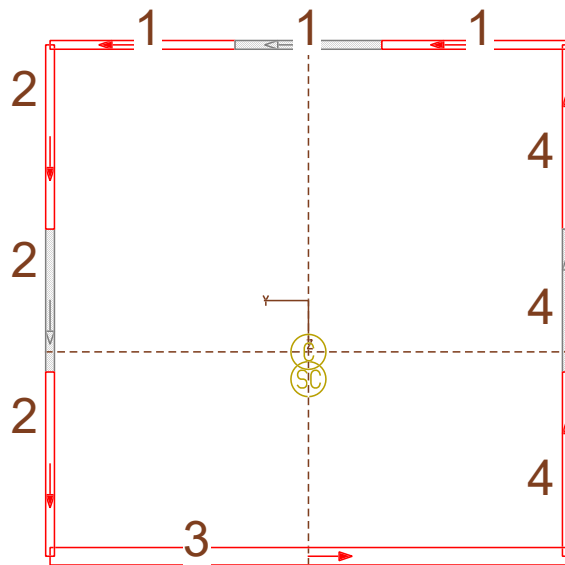

Figure 31.3: Effective area for uniform compression

### Determination of the characteristics of the gross cross section

$$S_y = b \cdot t_{f1} \cdot \left( h - \frac{t_{f1} + t_{f2}}{2} \right) + 2 \cdot h_w \cdot t_w \cdot \left( \frac{h_w + t_{f2}}{2} \right)$$

$$S_y = \frac{1}{29400} \left[ 600 \cdot 10 \cdot \left( 600 - \frac{10 + 20}{2} \right) + 2 \cdot 570 \cdot 10 \cdot \left( 600 - \frac{570 + 20}{2} \right) \right]$$

$$S_y = 6.873 \cdot 10^6 \text{ mm}^3$$

$$r_t = \frac{S_y}{A} = \frac{6.873 \cdot 10^6}{29400.0} = 233.8 \text{ mm}$$

where:

$S_y$  is the first moment of area of the gross cross section with respect to the centroid of the lower flange (y-y axis),

$r_t$  is the distance from the centroid of the lower flange to the centroid of the gross cross-section

### Calculation of effective<sup>D</sup> width of the upper flange

$$\psi = 1.0 \rightarrow k_\sigma = 4.0$$

$$\bar{\lambda}_p = \frac{b_{f1}}{t_{f1} \cdot 28.4 \cdot \varepsilon \cdot \sqrt{k_\sigma}} = \frac{580}{10 \cdot 28.4 \cdot 0.924 \cdot \sqrt{4.0}} = 1.105$$

$$\bar{\lambda}_p = 1.105 > 0.5 + \sqrt{0.085 - 0.055 \cdot \psi}$$

$$= 0.5 + \sqrt{0.085 - 0.055 \cdot 1} = 0.673$$

Plate elements without longitudinal stiffeners, EN 1993-1-5, 4.4

$$\rho = \frac{\bar{\lambda}_p - 0.055 \cdot (3 + \psi)}{\bar{\lambda}_p^2} = \frac{1.105 - 0.055 \cdot (3 + 1)}{1.105^2} = 0.725$$

$$b_{eff,f} = \rho \cdot b_{f1} = 0.725 \cdot 580 = 420.5 \text{ mm}$$

$$b_{e1,f} = b_{e2,f} = 0.5 \cdot b_{eff,f} = 0.5 \cdot 420.5 = 210.2 \text{ mm}$$

#### Calculation of effective<sup>p</sup> width of the web

$$\psi = 1.0 \rightarrow k_\sigma = 4.0$$

Plate elements without longitudinal stiffeners, EN 1993-1-5, 4.4

$$\bar{\lambda}_p = \frac{h_w}{t_w \cdot 28.4 \cdot \varepsilon \cdot \sqrt{k_\sigma}} = \frac{570}{10 \cdot 28.4 \cdot 0.924 \cdot \sqrt{4.0}} = 1.086$$

$$\bar{\lambda}_p = 1.086 > 0.5 + \sqrt{0.085 - 0.055 \cdot \varphi}$$

$$\bar{\lambda}_p = 1.086 > 0.5 + \sqrt{0.085 - 0.055 \cdot 1} = 0.673$$

$$\rho = \frac{\bar{\lambda}_p - 0.055 \cdot (3 + \varphi)}{\bar{\lambda}_p^2} = \frac{1.086 - 0.055 \cdot (3 + 1)}{1.086^2} = 0.734$$

$$b_{eff,w} = \rho \cdot h_w = 0.734 \cdot 570 = 418.7 \text{ mm}$$

$$b_{e1,w} = b_{e2,w} = 0.5 \cdot b_{eff,w} = 0.5 \cdot 418.7 = 209.3 \text{ mm}$$

#### Determination of characteristics of effective cross section considering effective widths of the upper flange and webs in uniform compression

$$x_f = b_{f1} - b_{eff,f} = 580.0 - 420.5 = 159.5 \text{ mm}$$

$$x_w = h_w - b_{eff,w} = 570.0 - 418.7 = 151.3 \text{ mm}$$

$$A_{eff} = [A - (x_f \cdot t_{f1} + 2 \cdot x_w \cdot t_w)]$$

$$A_{eff} = 29400 - (159.5 \cdot 10 + 2 \cdot 151.3 \cdot 10) = 24778.1 \text{ mm}^2$$

$$r_f = h - \frac{t_{f1} + t_{f2}}{2} - r_t = 600 - \frac{10 + 20}{2} = 351.2 \text{ mm}$$

$$r_w = h_w + \frac{t_{f2}}{2} - r_T - b_{e1,w} - \frac{x_w}{2}$$

$$r_w = 570 + \frac{10}{2} - 233.8 - 209.3 - \frac{151.3}{2} = 61.2 \text{ mm}$$

$$e_{N,y} = \frac{2 \cdot r_w \cdot x_w \cdot t_w + r_f \cdot x_f \cdot t_{f1}}{A_{eff}}$$

$$e_{N,y} = \frac{2 \cdot 61.2 \cdot 151.3 \cdot 10 + 351.2 \cdot 159.5 \cdot 10}{24778.1} = 30.1 \text{ mm}$$

$$r_{Teff,N} = r_T - e_{N,y} = 233.8 - 30.1 = 203.7 \text{ mm}$$

where:

$e_{N,y}$  is the shift of centroid of the effective area relative to the centre of gravity of the gross cross section determined assuming uniform



axial compression.

$r_{Teff,N}$  is the distance from the centroid of the bottom flange to the centroid of the effective cross-section under uniform compression.

**STEP 3:** Calculating the effective properties assuming the cross-section is subject only to bending stresses

The effective section modulus  $W_{eff,y}$  is determined on the cross-section subject only to bending moment.

### Cross section class check

Upper flange (compression  $\hat{\sigma}$  the same as in 1): Class 4

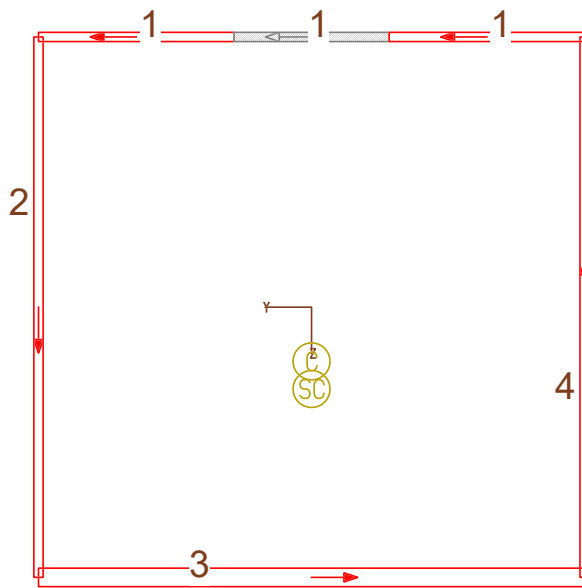

Figure 31.4: Effective area for bending

**Determination of characteristics of effective cross section** considering effective widths of the upper flange (calculation of effective width of the upper flange is already done in section 1) and gross cross section of the web:

$$A_{eff} = A - x_f \cdot t_f$$

$$A_{eff} = 29400 - 159.5 \cdot 10 = 27804.9 \text{ mm}^2$$

$$\Delta r_{T,M} = \frac{r_f \cdot x_f \cdot t_f}{A_{eff}} = \frac{351.2 \cdot 159.5 \cdot 10}{24778.1} = 20.1 \text{ mm}$$

$$r_{Teff,M} = r_T - \Delta r_{T,M} = 233.8 - 20.1 = 213.6 \text{ mm}$$

$$I_{eff,y}^I = I_y + A_{eff} \cdot \Delta r_{T,M}^2 - \left( \frac{x_f \cdot t_f^3}{12} + x_f \cdot t_f \cdot (r_f + \Delta r_{T,M})^2 \right)$$

$$I_{eff,y}^I = 1.748 \cdot 10^9 + 27804.9 \cdot 20.1^2 - \left( \frac{159.5 \cdot 10^3}{12} + \right)$$

$$159.5 \cdot 10 \cdot (351.2 + 20.1)^2 = 1.539 \cdot 10^9 \text{ mm}^4$$

where:

$I_{eff,y}^I$  is the effective second moment of area (cross section under pure bending) with respect to y-y considering the effective width of the upper flange.

The effective section moduli at the upper and lower edge of the girder's web,  $W_{eff,y,1}^I$  and  $W_{eff,y,2}^I$  are, respectively:

$$W_{eff,y,1}^I = \frac{I_{eff,y}^I}{h_w + \frac{t_{f2}}{2} - r_{Teff,M}}$$

$$W_{eff,y,1}^I = \frac{1.540 \cdot 10^9}{570 - \frac{20}{3} - 213.6} = 4.20 \cdot 10^6 \text{ mm}^3$$

$$W_{eff,y,2}^I = \frac{I_{eff,y}^I}{r_{Teff,M} - \frac{t_{f2}}{2}}$$

$$W_{eff,y,2}^I = \frac{1.540 \cdot 10^9}{213.6 - \frac{20}{2}} = 7.558 \cdot 10^6 \text{ mm}^3$$

Web (bending):

$$\psi^I = \frac{\sigma_2^I}{\sigma_1^I} = \frac{M_{y,Ed}/W_{eff,y,2}^I}{M_{y,Ed}/W_{eff,y,1}^I} = \frac{W_{eff,y,1}^I}{W_{eff,y,2}^I} = \frac{4.20 \cdot 10^6}{7.558 \cdot 10^6}$$

$$\psi^I = -0.56 > -1$$

$$\frac{h_w}{t_w} = \frac{570}{10} = 57.0 > \frac{42 \cdot \epsilon}{0.67 + 0.33 \cdot \psi^I} = \frac{42 \cdot 0.924}{0.67 - 0.33 \cdot 0.56}$$

$$\frac{h_w}{t_w} = 57.0 > 79.8 \text{ (Class 3)}$$

The web is at least of Class 3.

In case of a slender web, the effective<sup>p</sup> width should be determined on the basis of stress ratio  $\psi^I$ .

The effective section modulus  $W_{eff,y}$  for the design resistance to uniform bending is defined as the smallest value of the effective section moduli at the centroid of the upper and lower flange,  $W_{eff,y,1}^I$  and  $W_{eff,y,2}^I$ , respectively:

$$W_{eff,y,1}^I = \frac{I_{eff,y}^I}{h_w + \frac{t_{f1} + t_{f2}}{2} - r_{Teff,M}} = \frac{1.540 \cdot 10^9}{570 - \frac{10 + 20}{2} - 213.6}$$

$$W_{eff,y,1}^I = 4.144 \cdot 10^6 \text{ mm}^3$$

$$W_{eff,y,2} = \frac{I_{eff,y}^I}{z_{Teff}} = \frac{1.540 \cdot 10^9}{213.6} = 7.205 \cdot 10^6 \text{ mm}^3$$

Here,  $W_{eff,y,1}$  governs.

#### STEP 4: Cross section resistance check

Additional bending moment  $N_{Ed} \cdot e_{N,y}$  causes compression at the upper flange (+compression).

$$\begin{aligned} & \frac{N_{Ed}}{A_{eff} \cdot f_y / \gamma_{M0}} + \frac{N_{Ed} \cdot e_{N,y}}{W_{eff,y,1} \cdot f_y / \gamma_{M0}} \\ &= \frac{5.5 \cdot 10^6}{24778.1 \cdot 275 / 1.0} + \frac{5.5 \cdot 10^6 \cdot 30.1}{4.144 \cdot 10^6 \cdot 275 / 1.0} \\ &= 0.807 + 0.145 \\ &= 0.95 < 1.0 \text{ Satisfactory} \end{aligned}$$

Class 4-sections, EN 1993-1-1, 6.2.9.3, Eq. 6.44

## 2. STABILITY CHECK

In this example Method 2 is applied. Since the member has a rectangular hollow cross-section, the member is not susceptible to torsional deformation, so flexural buckling constitutes the relevant instability mode and  $\chi_{LT} = 1.00$

#### STEP 1: Characteristic resistance of the section

$$N_{Rk} = A \cdot f_y = 24778.1 \cdot 275 = 6813977.5 \text{ N} = 6813.97 \text{ kN}$$

$$M_{y,Rk} = W_{pl,y} \cdot f_y = 4.144 \cdot 10^6 \cdot 275 = 1139.6 \cdot 10^{-6} \text{ Nm}$$

$$M_{y,Rk} = 1139.6 \text{ kNm}$$

$N_{Rk}$  is calculated assuming that the cross-section is subject only to stresses due to uniform axial compression, EN 1993-1-5, 4.3(4).

$M_{y,Rk}$  is calculated assuming the cross section is subject only to bending stresses, EN 1993-1-5, 4.3(4)

#### STEP 2: Reduction coefficients due to flexural buckling, $\chi_y$ and $\chi_z$

##### Plane xz (buckling about y)

$$L_{cr,y} = \beta \cdot L = 4.00 \text{ m}$$

$$\bar{\lambda}_y = \frac{L_{cr,y}}{i_y} \cdot \frac{\sqrt{A_{eff}}}{\lambda_1}$$

EN 1993-1-1, Eq. 6.51

$$i_y = \sqrt{\frac{I_y}{A}} = \sqrt{\frac{174700.00}{294.00}} = 24.38 \text{ cm}$$

$$\lambda_1 = 93.9 \cdot \varepsilon$$

$$\varepsilon = \sqrt{\frac{235}{f_y}} = \sqrt{\frac{235}{275}} = 0.9244$$

$$\bar{\lambda}_y = \frac{400}{24.38} \cdot \frac{\sqrt{\frac{247.78}{294.00}}}{93.9 \cdot 0.9244}$$

EN 1993-1-1, Eq. 6.51

$$\bar{\lambda}_y = 0.173$$

Buckling curves, EN 1993-1-1, Table 6.2

 $\alpha = 0.34$  Curve b

$$\phi = 0.5 \cdot [1 + \alpha \cdot (\bar{\lambda}_y - 0.2) + \bar{\lambda}_y^2]$$

$$\phi = 0.5 [1 + 0.34 \cdot (0.173 - 0.2) + 0.173^2]$$

$$\phi = 0.51$$

 $\chi, \phi$ , EN 1993-1-1, Eq. 6.49

$$\chi_y = \frac{1}{\phi + \sqrt{\phi^2 - \bar{\lambda}_y^2}} \leq 1.0$$

$$\chi_y = \frac{1}{0.51 + \sqrt{0.51^2 - 0.173^2}}$$

$$\chi_y = 1.01 \leq 1.0 \rightarrow \chi_y = 1.0$$

**Plane xy (buckling about z):**

$$L_{cr,z} = \beta \cdot L = 4.00 \text{ m}$$

EN 1993-1-1, Eq. 6.51

$$\bar{\lambda}_z = \frac{L_{cr,z}}{i_z} \cdot \frac{\sqrt{\frac{A_{eff}}{A}}}{\lambda_1}$$

$$i_z = \sqrt{\frac{I_z}{A}} = \sqrt{\frac{153200.00}{294.00}} = 22.82 \text{ cm}$$

EN 1993-1-1, Eq. 6.51

$$\bar{\lambda}_z = \frac{400}{22.82} \cdot \frac{\sqrt{\frac{247.78}{294.00}}}{93.9 \cdot 0.9244}$$

$$\bar{\lambda}_z = 0.185$$

Buckling curves, EN 1993-1-1, Table 6.2

 $\alpha = 0.34$  Curve b

$$\phi = 0.5 \cdot [1 + \alpha \cdot (\bar{\lambda}_z - 0.2) + \bar{\lambda}_z^2]$$

$$\phi = 0.5 [1 + 0.34 \cdot (0.185 - 0.2) + 0.185^2]$$

$$\phi = 0.51$$

 $\chi, \phi$ , EN 1993-1-1, Eq. 6.49

$$\chi_z = \frac{1}{\phi + \sqrt{\phi^2 - \bar{\lambda}_z^2}} \leq 1.0$$

$$\chi_z = \frac{1}{0.51 + \sqrt{0.51^2 - 0.173^2}}$$

$$\chi_z = 1.01 \leq 1.0 \rightarrow \chi_z = 1.0$$

**STEP 3:** Calculating of the interaction factors  $k_{yy}$  and  $k_{zy}$ 

$$\psi_y = M_{y,Ed,base} / M_{Ed,top} = 175.5 / 175.5 = 1.0$$

Table B.3 of EN 1993-1-1 gives:

 Interaction factors  $k_{ij}$  for members not susceptible to torsional deformations, Annex B, Table B.1

$$C_{my} = 0.6 + 0.4 \cdot \psi_y \geq 0.4$$

$$C_{my} = 0.6 + 0.4 \cdot 1.0 = 1.0$$

$$k_{yy} = C_{my} \cdot \left( 1 + 0.6 \cdot \bar{\lambda}_y \cdot \frac{N_{Ed}}{\chi_y \cdot N_{Rk}} \right) \leq C_{my} \cdot \left( 1 + 0.6 \cdot \frac{N_{Ed}}{\chi_y \cdot N_{Rk}} \right)$$

$$k_{yy} = 1.0 \cdot \left( 1 + 0.6 \cdot 0.173 \cdot \frac{5500}{1.0 \cdot 6813.97} \right) \\ \leq 1.0 \cdot \left( 1 + 0.6 \cdot \frac{5500}{0.173 \cdot 6813.97} \right)$$

$$k_{yy} = 1.0837 \leq 1.484$$

$$k_{zy} = 0.8 \cdot k_{yy} = 1.084 \cdot 0.8 = 0.867$$

### Final expression

Check for y-y

$$\frac{N_{Ed}}{\chi_y \cdot \frac{N_{Rk}}{\gamma_{M1}}} + k_{yy} \cdot \frac{M_{y,Ed}}{\chi_{LT} \cdot \frac{M_{y,Rk}}{\gamma_{M1}}} \leq 1.0$$

$$\frac{5500}{1.0 \cdot \frac{6813.9}{1.0}} + 1.084 \cdot \frac{175}{1.0 \cdot \frac{1139.6}{1.0}} \leq 1.0$$

$$0.807 + 0.166 = 0.973 \leq 1.0 \rightarrow \text{Satisfied}$$

Check for z-z

$$\frac{N_{Ed}}{\chi_z \cdot \frac{N_{Rk}}{\gamma_{M1}}} + k_{zy} \cdot \frac{M_{y,Ed}}{\chi_{LT} \cdot \frac{M_{y,Rk}}{\gamma_{M1}}} \leq 1.0$$

$$\frac{5500}{1.0 \cdot \frac{6813.9}{1.0}} + 0.867 \cdot \frac{175}{1.0 \cdot \frac{1139.6}{1.0}} \leq 1.0$$

$$0.807 + 0.133 = 0.94 \leq 1.0 \rightarrow \text{Satisfied}$$

Uniform members in bending and axial compression, EN 1993-1-1, 6.3.3, Eq. 6.61

Uniform members in bending and axial compression, EN 1993-1-1, 6.3.3, Eq. 6.62

## 31.5 Conclusion

In the reference example, the effective area  $A_{eff}$  is determined assuming that the cross-section is subjected only to stresses due to uniform axial compression (EN 1993-1-5, 4.3(3))  $A_{c,eff} = \rho \cdot A_c$ . The effective section modulus  $W_{eff}$  is determined assuming the cross-section is subject to only bending stresses (EN 1993-1-5, 4.3(3)).

By using the NEFF SIG SMIN input it is possible to define only one effective cross-section for the design and stability check, therefore the effective section modulus is determined assuming that the cross-section is subject only to stresses due uniform axial compression. The  $A_{eff}$  as well as  $W_{eff,y}$  and  $W_{eff,z}$  values are calculated in SOFiSTiK for the effective cross-section as shown in Fig. 31.3. This approach checks the MOST UNFAVOURABLE case where all plates are under compression.

By using the iterative method (EN 1993-1-5, Annex E) for calculating the effective cross-section properties, the effective CS properties will be calculated for the current stress state, so it gives more realistic and economical results as shown in table 31.2. The iterative method can be used ONLY for the THIN-WALLED cross-sections. In Fig. 31.5 you will find the comparison between "SIG NEFF", "Iterative approach" and the reference.

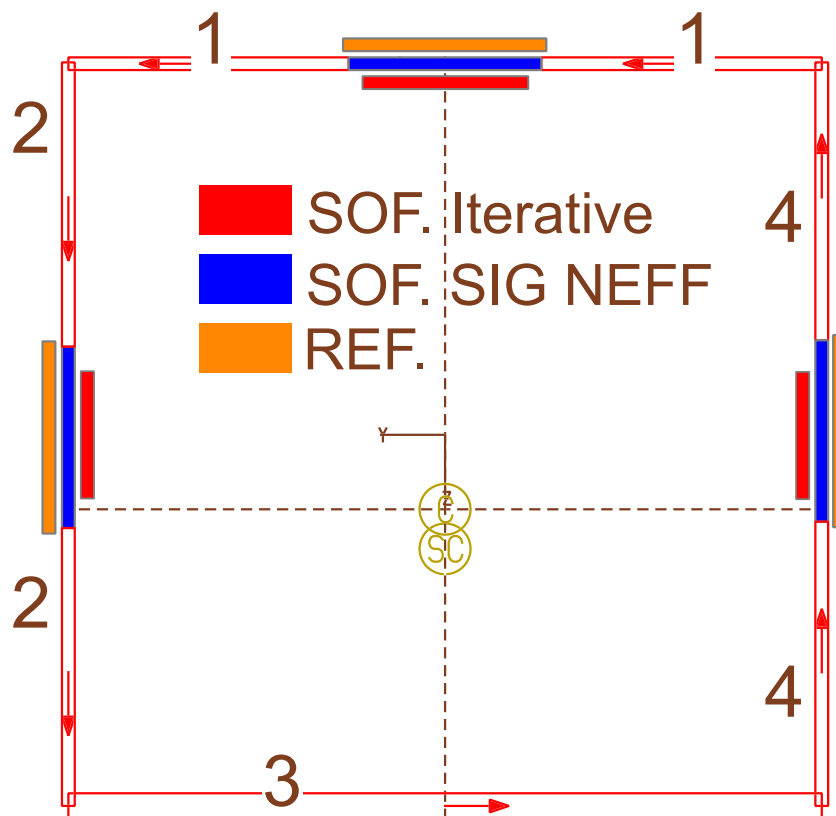

Figure 31.5: Comparison of the  $b_{i,eff}$  values

## 31.6 Literature

- [7] EN 1993-1-1: Eurocode 3: Design of concrete structures, Part 1-1: General rules and rules for buildings. CEN. 2005.
- [21] DIN EN 1993-1-1:2005 Eurocode 3: Design of steel structures, Part 1-1: General rules and rules for buildings - Deutsche Fassung EN 1993-1-1:2005 + AC:2009. CEN. 2010.
- [22] D. Beg et al. Design of Plated Structures. Ernst & Sohn and ECCS, 2010.

- [23] EN 1993-1-5: Eurocode 3: Design of steel structures, Part 1-5: Plated structural elements. CEN. 2006.
-





## 32 DCE-EN31: Punching of flat slab acc. DIN EN 1992-1-1

### Overview

<b>Design Code Family(s):</b>	DIN
<b>Design Code(s):</b>	DIN EN 1992-1-1
<b>Module(s):</b>	BEMESS
<b>Input file(s):</b>	<a href="#">punching_din_en_1992.dat</a>

### 32.1 Problem Description

The problem consist of a flat slab of a multi-story building as shown in Fig. 32.1. The design of slab against punching at the columns is discussed in the following.

For the concrete, strength class C35/45 ( $f_{ck} = 35 \text{ MPa}$ ,  $\gamma_c = 1.5$ ) is assumed, for the reinforcing steel, grade B500B ( $f_{yk} = 500 \text{ MPa}$ ,  $E_s = 205 \text{ GPa}$ ,  $\gamma_s = 1.15$ , ductility class B). The factored design load accounting for self-weight, dead load and imposed load is  $e_d = 14.67 \text{ kN/m}^2$ .

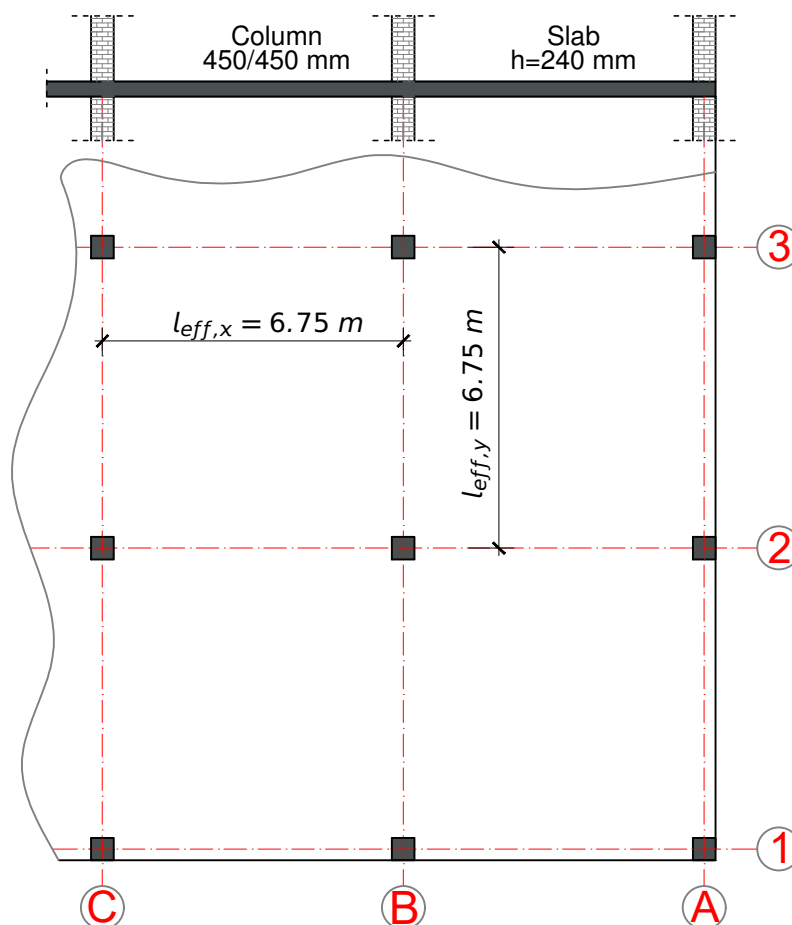

Figure 32.1: Model

## 32.2 Reference Solution

This example is concerned with the punching of flat slabs. The content of this problem is covered by the following parts of DIN EN 1992-1-1:2004 + AC:2010 [1]:

- Construction materials (Section 3)
- Punching (Section 6.4)

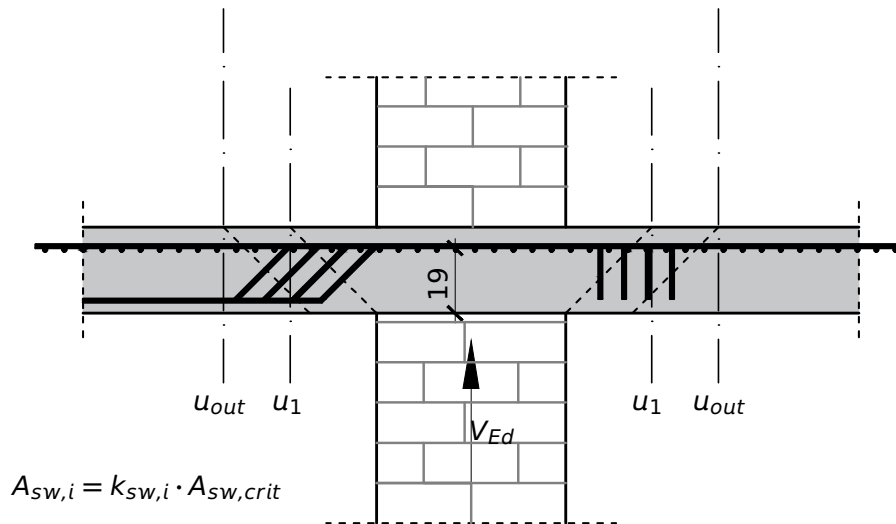

Figure 32.2: Punching

## 32.3 Model and Results

The goal of the preliminary design is to check if the dimensions of the structure are reasonable with respect to the punching shear strength and if punching shear reinforcement is required.

In the reference example the reaction forces are estimated by using contributive areas, therefore the example has been splitted into three models to show the punching for

- the inner column B2,
- the edge column A2/B1,
- wall at position B2.

The SOFiSTiK and reference results are given in Table 32.3.

Table 32.1: Results

Result	SOF.	Ref.
Inner column B2 (Node 1)		
$V_{Ed}$ [kN]	808.0	809.0
$V_{Ed,red}$ [kN]	803.0	—
$v_{Ed}$ [N/mm <sup>2</sup> ]	1.11	1.12

Table 32.1: (continued)

Result	SOF.	Ref.
$v_{Rd,c}$ [ $N/mm^2$ ]	0.93	0.93
$v_{Rd,max}$ [ $N/mm^2$ ]	1.30	1.30
$u_{out}$ [ $m$ ]	6.01	6.05
$u_1$ [ $m$ ]	4.188	4.19
$\beta$	1.10	1.10
$d$ [ $m$ ]	0.19	0.19
Edge column B1/A2 (Node 2)		
$V_{Ed}$ [ $kN$ ]	317.5	319
$V_{Ed,red}$ [ $kN$ ]	312.5	—
$v_{Ed}$ [ $N/mm^2$ ]	1.17	0.925
$v_{Rd,c}$ [ $N/mm^2$ ]	0.86	0.86
$v_{Rd,max}$ [ $N/mm^2$ ]	1.21	1.204
$u_{out}$ [ $m$ ]	3.21	3.28
$u_1$ [ $m$ ]	2.539	2.54
$\beta$	1.40	1.40
$d$ [ $m$ ]	0.19	0.19
Wall B2 (Node 1014)		
$V_{Ed}$ [ $kN$ ]	360.8	381.0
$V_{Ed,red}$ [ $kN$ ]	—	—
$v_{Ed}$ [ $N/mm^2$ ]	1.14	1.20
$v_{Rd,c}$ [ $N/mm^2$ ]	0.88	0.878
$v_{Rd,max}$ [ $N/mm^2$ ]	1.23	1.229
$u_{out}$ [ $m$ ]	3.50	3.69
$u_1$ [ $m$ ]	2.244	2.24
$\beta$	1.35	1.35
$d$ [ $m$ ]	0.19	0.19

## 32.4 Design Process<sup>1</sup>

The calculation steps of the reference solution are presented below.

### 32.4.1 Material

3.1 Concrete

Characteristic value of cylinder compressive strength

▣ Concrete 35/45

$$f_{ck} = 35 \text{ N/mm}^2$$

$$f_{cd} = \alpha_{cc} \cdot \frac{f_{ck}}{\gamma_c}$$

$$f_{cd} = 0.85 \cdot \frac{35}{1.5} = 19.80 \text{ N/mm}^2$$

3.2 Reinforcing steel

3.2.2

▣ Steel B500B (flexural and transverse reinforcement)

$$f_{yk} = 500 \text{ MPa}$$

$$f_{yd} = \frac{f_{yk}}{\gamma_s} = 435.00 \text{ N/mm}^2$$

$$E_s = 205000 \text{ MPa}$$

Ductility class: B

### 32.4.2 Actions and Loads

Table 32.2: Characteristic actions

Action	Characteristic value $kN/m^2$
Dead-weight ( $g_k$ )	7.25
Variable load ( $q_k$ )	3.25

▣ Combined loads for design:

$$g_d = \gamma_G \cdot g_k = 1.35 \cdot 7.25 = 9.79 \text{ kN/m}^2$$

$$q_d = \gamma_Q \cdot q_{k,1} = 1.50 \cdot 3.25 = 4.88 \text{ kN/m}^2$$

$$e_d = g_d + q_d = 9.79 + 4.88 = 14.67 \text{ kN/m}^2$$

### 32.4.3 Punching check for inner Column

▣ Calculating effective depth  $d$  in  $x$  direction:

$$\begin{aligned} d_x &= h - c_{v,l} - 0.5 \cdot \phi \\ &= 240 - 30 - 10 \\ &= 200 \text{ mm} \end{aligned}$$

<sup>1</sup>The sections mentioned in the margins refer to DIN EN 1992-1-1 [1] unless otherwise specified.



Table 32.3: (continued)

Column Type	Axis	Area [m <sup>2</sup> ]	V <sub>Ed</sub> [kN]
Corner column	A/1	8.56	139.90

▣ Effective depth  $d$

$$d = \frac{d_x + d_y}{2}$$

$$d = \frac{0.2 + 0.18}{2}$$

$$d = 0.19 \text{ m}$$

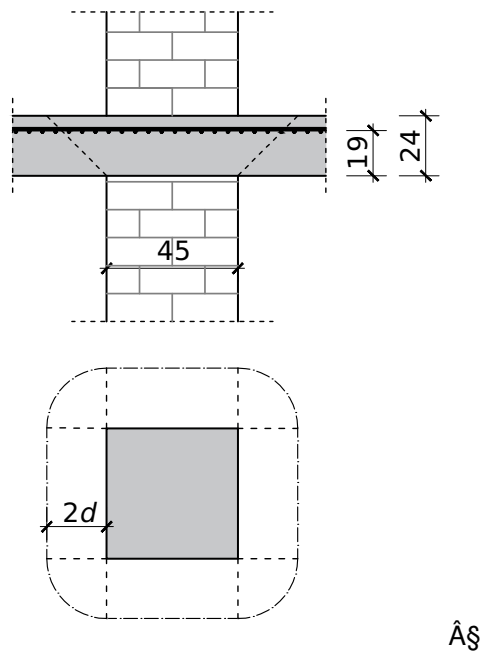

Figure 32.4: Punching - inner column

▣ Perimeter  $u_0$  and  $u_1$

$$u_0 = 4 \cdot 0.45 = 1.80 \text{ m}$$

$$u_1 = 2 \cdot (2 \cdot 0.45 + \pi \cdot 2.0 \cdot 0.19)$$

$$u_1 = 4.19 \text{ m}$$

▣ Max. shear force (column B/2):

$$V_{Ed} = \frac{\beta \cdot V_{Ed}}{u_i \cdot d}$$

$$V_{Ed} = 809 \text{ kN}$$

6.4.3, Eq. 6.38

BEMESS is reducing the  $V_{Ed}$  value by dead load of the slab.

$$V_{Ed,red} = V_{Ed} - V_{red}$$

$$V_{red} = 1.35 \cdot \gamma_c \cdot r_{col,eff}^2 \cdot \pi \cdot h_{slab}$$

Where:

$r_{col,eff}$  is the effective radius of the column

$\gamma_c$  is the nominal weight of the concrete in  $kN/m^3$

$r_{col,eff}^2 \cdot \pi$  is the effective area

$h_{slab}$  height of the slab

$$A_{col} = a \cdot b \text{ or } A_{col} = a^2 \text{ (if } a=b\text{)}$$

$$r_{col,eff} = \sqrt{\frac{A_{col}}{\pi}} + d$$

$$\beta = 1.10$$

In BEMESS the  $\beta$  value is limited to  $\beta_{max} = 1.8$ .

Min. value is taken as  $\beta_{min} = 1.1$

$$1.1 \leq \beta \leq 1.8$$

$$\beta = 1 + k \cdot \frac{M_{Ed}}{V_{Ed} \cdot \frac{u_1}{W_1}}$$

The  $W_i$  value is calculated acc.  $W_i = \int_0^{u_i} |e| dl$

NDP, 6.4.3(6),  $\beta = 1.1$  for inner columns

6.4.3, Eq. 6.39 and Eq. 6.40

$$V_{Ed} = \frac{0.809 \cdot 1.10}{4.19 \cdot 0.19} = 1.118 \text{ MN/m}^2$$

### Shear resistance without punching reinforcement

$$\text{for } \frac{u_0}{d} = \frac{1.80}{0.19} = 9.5 > 4$$

$$V_{Rd,c} = \frac{0.18}{\gamma_c} \cdot k \cdot (100 \cdot \rho_l \cdot f_{ck})^{1/3} + 0.1 \cdot \sigma_{cp} \geq v_{min} + 0.10 \cdot \sigma_{cp}$$

NDP, 6.4.4(1), Eq. 6.47, slabs without punching reinforcement

with:

$$k = 1 + (200/d)^{1/2} \leq 2.0$$

$$k = 1 + (200/190)^{1/2} = 2.0$$

$$v_{min} = (0.0525/\gamma_c) \cdot k^{3/2} \cdot f_{ck}^{1/2}$$

$$v_{min} = (0.05252/1.5) \cdot 2.0^{3/2} \cdot 35^{1/2} = 0.586 \text{ MN/m}^2$$

$k > 2.0$ , because  $d = 190 \text{ mm} < 200 \text{ mm}$

NCI, 6.2.2, Eq. 6.3DE for  $d \leq 600$

### Reinforcement ratio for longitudinal reinforcement

over column B/2 - width of the strip

$$b = 0.4 \cdot 6.75 \text{ m} = 2.70 \text{ m} > b_p = 0.45 + 2 \cdot 3.0 \cdot 0.19 = 1.59 \text{ m}$$

▣ Reinforcement ratio

$$\rho_{l,x} = \frac{31.42}{100 \cdot 20} = 0.0157$$

$$\rho_{l,y} = \frac{31.42}{100 \cdot 18} = 0.0175$$

$$\rho_l = (\rho_{l,x} \cdot \rho_{l,y})^{1/2}$$

$$= (0.0157 \cdot 0.0175)^{1/2}$$

$$= 0.0166$$

$$\leq 0.02$$

$$\leq 0.50 \cdot \frac{f_{cd}}{f_{yd}} = 0.5 \cdot \frac{19.8}{435} = 0.023$$

$$v_{Rd,c} = \frac{0.18}{1.5} \cdot 2.0 \cdot (100 \cdot 0.0166 \cdot 35)^{1/3}$$

$$v_{Rd,c} = 0.928 \text{ MN/m}^2 > v_{min}$$

$$< v_{Ed} = 1.118 \text{ MN/m}^2$$

⇒ Punching reinforcement is required!

### Slab with punching reinforcement

$$v_{Rd,max} = 1.4 \cdot v_{Rd,c}$$

$$= 1.4 \cdot 0.928 = 1.299 \text{ MN/m}^2$$

$$> v_{Ed} = 1.118 \text{ MN/m}^2$$

⇒  $v_{Ed}$  the punching reinforcement can be used

Punching reinforcement  $\alpha = 90^\circ$

$$u_{out} = \beta \cdot \frac{V_{Ed}}{v_{Rd,c} \cdot d}$$

$$u_{out} = 1.10 \cdot \frac{0.809}{0.928 \cdot \frac{0.15}{0.18} \cdot 0.19}$$

$$u_{out} = 6.05 \text{ m}$$

Loaded area perimeter  $A_{load}$

$$\begin{aligned} a_{out} &= \frac{u_{out} - u_0}{2 \cdot \pi} \\ &= \frac{6.05 - 1.80}{2 \cdot \pi} \\ &= 0.67 \text{ m} \Rightarrow \approx 3.52 \cdot d \end{aligned}$$

The punching reinforcement is required until  $(3.52 - 1.5) \cdot d = 2.02 \cdot d$

$$v_{Rd,cs} = 0.75 \cdot v_{rd,c} + 1.5 \cdot (d/s_r) \cdot \frac{A_{sw} \cdot f_{ywed,ef} \cdot \sin \alpha}{u_1 \cdot d}$$

$v_{Rd,max}$   
(NDP) 6.4.5(3) Eq.(NA.6.53.1)

(NCI) for 6.4.5 (4): For  $u_{out} \rightarrow v_{Rd,c}$   
is used according to 6.2.2 (1),  $C_{Rd,c} =$   
 $0.15/\gamma_c$  and not  $0.18/\gamma_c$



with:

$$f_{ywd,ef} = 250 + 0.25 \cdot d \leq f_{ywd}$$

$$f_{ywd,ef} = 250 + 0.25 \cdot 190 = 297 \text{ MN/m}^2 < 435 \text{ MN/m}^2$$

$$s_r = 0.75 \cdot d$$

$$A_{sw} = \frac{(V_{Ed} - 0.75 \cdot V_{Rd,c}) \cdot u_1 \cdot d}{1.5 \cdot \frac{d}{s_r} \cdot f_{ywd,ef}}$$

$$A_{sw} = \frac{(1.118 - 0.75 \cdot 0.928) \cdot 4.19 \cdot 0.19}{1.5 \cdot \frac{1}{0.75} \cdot 297} \cdot 10^4$$

$$A_{sw} = 5.66 \text{ cm}^2$$

Reinforcement in perimeter 1 -  $A_{sw,1}$

$$reqA_{sw,1} = k_{sw} \cdot A_{sw}$$

$$reqA_{sw,1} = 2.5 \cdot 5.66 = 14.10 \text{ cm}^2$$

Reinforcement in perimeter 2 -  $A_{sw,2}$

$$reqA_{sw,2} = k_{sw} \cdot A_{sw}$$

$$reqA_{sw,2} = 1.4 \cdot 5.66 = 7.92 \text{ cm}^2$$

### Detailing of reinforcement

The spacing of link legs around a perimeter should not exceed  $1.5 \cdot d$  within the first control perimeter ( $2 \cdot d$  from loaded area), and should not exceed  $2 \cdot d$  for perimeters outside the first control perimeter where that part of the perimeter is assumed to contribute to the shear capacity.

$$u_{s1} = 2.40 \text{ m} \Rightarrow \min n = \frac{2.40}{1.5 \cdot 0.19} = 9$$

$$u_{s2} = 3.29 \text{ m} \Rightarrow \min n = \frac{3.29}{1.5 \cdot 0.19} = 12$$

Min. punching reinforcement:

$$A_{sw,min} = \frac{0.08}{1.5} \cdot \frac{\sqrt{f_{ck}}}{f_{yk}} \cdot s_r \cdot s_t$$

(NCI), 9.4.3: Eq. (9.11DE)

$$A_{sw,min} = 0.05333 \cdot \frac{\sqrt{35}}{500} \cdot 0.75 \cdot 1.5 \cdot 1.9^2$$

$$A_{sw,min} = 0.26 \text{ cm}^2$$

### 32.4.4 Punching check for edge column

The punching check for columns (A2/B1) is verified:

Slab: C35/45,  $d = 0.19 \text{ m}$

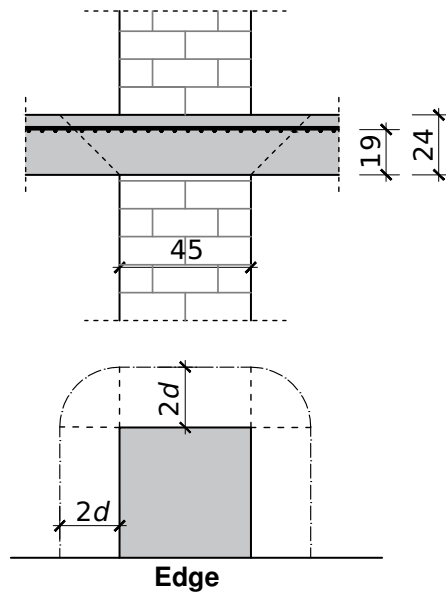

Å§

Figure 32.5: Punching - edge column B1/A2

▣ Critical perimeter

$$u_1 = 3 \cdot 0.45 + \pi \cdot 2.0 \cdot 0.19$$

$$u_1 = 2.54 \text{ m}$$

For edge and corner columns the effective perimeter is reduced based by using the *Sector Method* (See Fig. 32.6). The *Sector Method* delivers the effective perimeter  $u$  of the punching round cut. The ratio  $u/u_0$  is output in % in the result list.

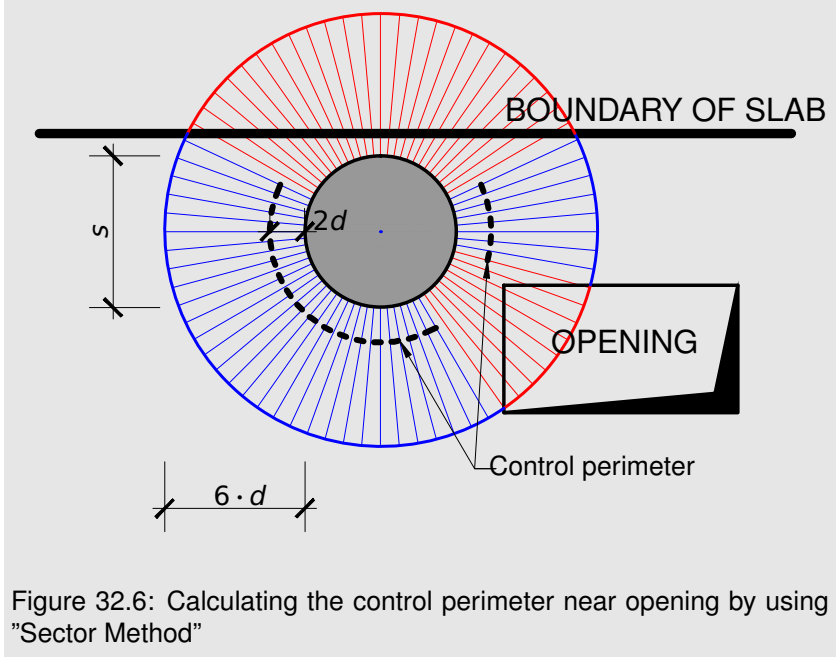

Figure 32.6: Calculating the control perimeter near opening by using "Sector Method"

▣ Maximal shear force:

$$V_{Ed} = 319 \text{ kN}$$

$$v_{Ed} = \frac{\beta \cdot V_{Ed}}{u_i \cdot d}$$

 $v_{Ed}$ , 6.4.3, Eq. 6.38

$$\beta = 1.4$$

 NDP, 6.4.3(6),  
 $\beta = 1.4$  for edge columns

$$v_{Ed} = \frac{1.40 \cdot 0.319}{2.54 \cdot 0.19}$$

$$v_{Ed} = 0.925 \text{ MN/m}^2$$

### Shear resistance without punching reinforcement

$$v_{Rd,c} = \frac{0.18}{\gamma_c} \cdot k \cdot (100 \cdot \rho_l \cdot f_{ck})^{1/3} \geq v_{min}$$

NDP, 6.4.4(1), Eq. 6.47, slabs without punching reinforcement

with

$$k = 2.0$$

$$v_{min} = 0.586 \text{ MN/m}^2$$

 $v_{min}$ , NCI, 6.2.2,  
 Eq. 6.3DE for  $d \leq 600$ 

 ▣ Reinforcement ration  $\rho_l$ :

(Parallel over the edge of column B/1)

$$\rho_{lx} = \frac{20.11}{100 \cdot 20} = 0.01$$

$$\rho_{ly} = \frac{31.42}{100 \cdot 18} = 0.0175$$

$$\rho_l = (0.01 \cdot 0.0175)^{1/2} = 0.0132$$

$$\leq 0.02$$

$$\leq 0.50 \cdot \frac{f_{cd}}{f_{yd}} = 0.023$$

$$v_{Rd,c} = \frac{0.18}{1.5} \cdot 2.0 \cdot (100 \cdot 0.0132 \cdot 35)^{1/3}$$

$$v_{Rd,c} = 0.860 \text{ MN/m}^2 > v_{min}$$

$$< 0.925 \text{ MN/m}^2$$

⇒ punching reinforcement is required!

### Slab with punching reinforcement

▣ Maximum shear force

$$v_{Rd,max} = 1.4 \cdot v_{Rd,c} = 1.4 \cdot 0.860$$

$$= 1.204 \text{ MN/m}^2 > v_{Ed} = 0.925 \text{ MN/m}^2$$

 $v_{Rd,max}$   
 (NDP) 6.4.5(3) Eq.(NA.6.53.1)

 ⇒ the punching reinforcement can bear the shear force  $v_{Ed}$ !

 Punching reinforcement  $\alpha = 90^\circ$

(NCI) for 6.4.5 (4): For  $u_{out} \rightarrow v_{Rd,c}$  is used according to 6.2.2 (1),  $C_{Rd,c} = 0.15/\gamma_c$  and not  $0.18/\gamma_c$

$$u_{out} = \beta \cdot \frac{V_{Ed}}{v_{Rd,c} \cdot d}$$

$$u_{out} = 1.4 \cdot \frac{0.319}{0.860 \cdot \frac{0.15}{0.18} \cdot 0.19}$$

$$u_{out} = 3.28 \text{ m}$$

▣ Loaded area perimeter  $A_{load}$

$$\begin{aligned} a_{out} &= \frac{u_{out} - u_o}{\pi} \\ &= \frac{3.28 - 3 \cdot 0.45}{\pi} = 0.61 \text{ m} \rightarrow \approx 3.21 \cdot d \end{aligned}$$

Punching reinforcement is required until  $(3.21 - 1.5) \cdot d = 1.71 \cdot d$

$$v_{Rd,s} = 0.75 + v_{Rd,c} + 1.5 \cdot \frac{d}{s_r} \cdot \frac{A_{sw} \cdot f_{ywd,ef} \cdot \sin \alpha}{u_1 \cdot d}$$

with

$$f_{ywd,ef} = 297 \text{ MN/m}^2$$

$$s_r = 0.5 \cdot d$$

$$A_{sw} = (v_{Ed} - 0.75 \cdot v_{Rd,c}) \cdot \frac{u_1 \cdot d}{1.5 \cdot \frac{d}{s_r} \cdot f_{ywd,ef}}$$

$$A_{sw} = (0.925 - 0.75 \cdot 0.860) \cdot \frac{2.54 \cdot 0.19 \cdot 10^4}{1.5 \cdot \frac{1}{0.5} \cdot 297}$$

$$A_{sw} = 1.51 \text{ cm}^2$$

Reinforcement in perimeter 1 -  $A_{sw,1}$

$$req A_{sw,1} = k_{sw} \cdot A_{sw}$$

$$req A_{sw,1} = 2.5 \cdot 1.51 = 3.79 \text{ cm}^2$$

Reinforcement in perimeter 2 -  $A_{sw,2}$

$$req A_{sw,2} = k_{sw} \cdot A_{sw}$$

$$req A_{sw,2} = 1.4 \cdot 1.51 = 2.12 \text{ cm}^2$$

(NCI), 9.4.3: Eq. (9.11DE)

$$A_{sw,min} = 0.26 \text{ cm}^2$$

### 32.4.5 Punching check for wall

The punching check is verified at position B2.

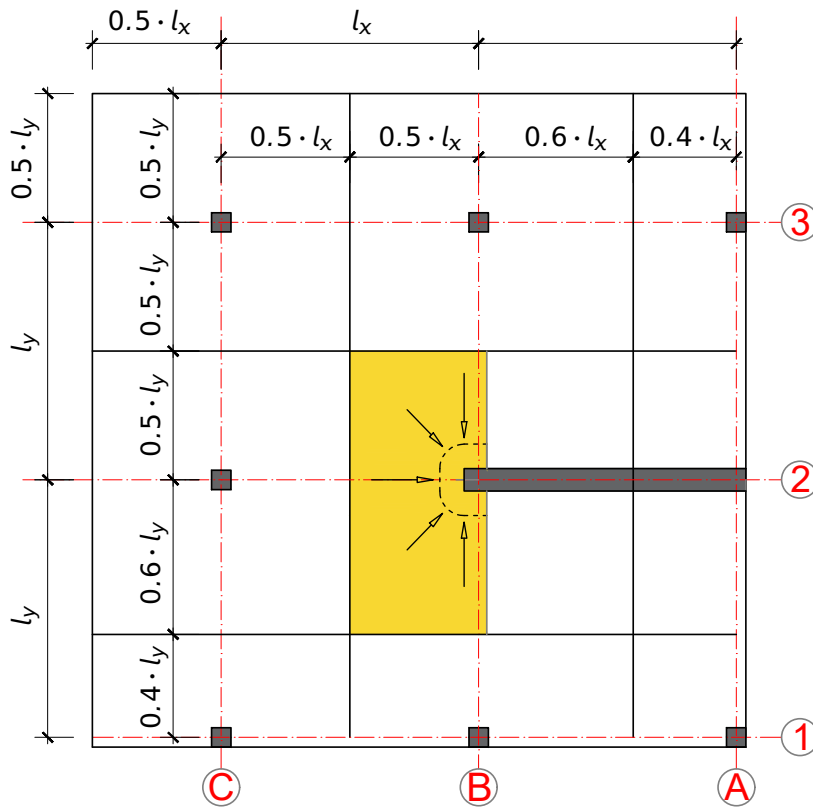

Figure 32.7: Load distribution - wall

$$d = 190 \text{ mm}$$

$$b_1 = b = 350 \text{ mm} < 3 \cdot d$$

$$\frac{a_1}{2} = b = 350 \text{ mm}$$

$$< 3 \cdot d - 0.5 \cdot b_1 = 3 \cdot 190 - 175 = 395 \text{ mm}$$

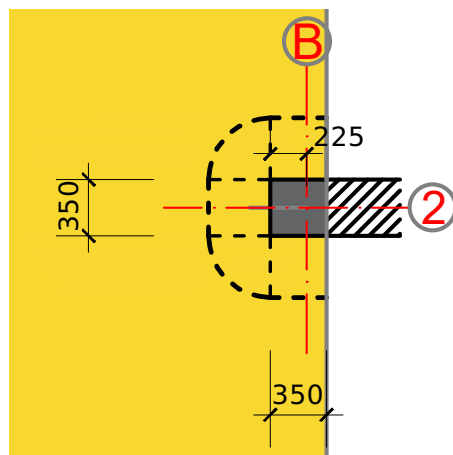

$$e_d = 14.67 \text{ kN/m}^2$$

Load distribution:

$$A_{LE} = (0.5 + 0.6) \cdot 6.75 \text{ m} \cdot (0.5 \cdot 6.75 \text{ m} + 0.125 \text{ m}) = 26.0 \text{ m}^2$$

$$V_{Ed} = A_{LE} \cdot e_d$$

$$V_{Ed} = 26.0 \cdot 14.67 = 381 \text{ kN}$$

For walls there are two methods to analyse the punching force at wall ends and corners. Default is the integration of the slab shear force along the critical perimeter. As the result varies depending on the distance to the wall, BEMESS analyses four distances and takes the maximum punching force.

Critical perimeter:

$$u_1 = 3 \cdot 0.35 + \phi \cdot 2.0 \cdot 0.19 = 2.24 \text{ m}$$

Max. shear force:

$$v_{Ed} = \frac{\beta \cdot V_{Ed}}{u_i \cdot d}$$

$\beta = 1.35$  for wall ending,  
(NDP) 6.4.3 (6)

$$\beta = 1.35$$

$$v_{Ed} = \frac{1.35 \cdot 0.381}{2.24 \cdot 0.19} = 1.208 \text{ MN/m}^2$$

### Shear resistance without punching reinforcement

NDP, 6.4.4(1), Eq. 6.47,  
slabs without punching reinforcement

$$v_{Rd,c} = \frac{0.18}{\gamma_c} \cdot k \cdot (100 \cdot \rho_l \cdot f_{ck})^{1/3} \geq v_{min}$$

with:

$$k = 2.0$$

$$v_{min} = 0.586 \text{ MN/m}^2$$

$v_{min}$ ; (NCI) 6.2.2;  
Eq. 6.3DE for  $d \leq 600 \text{ mm}$

▣ Reinforcement ration  $\rho_l$ :

(Parallel over the edge of wall B/2)

For this example we will take  $\rho_l = 1.4 \%$

$$\rho_l = 0.014$$

$$\leq 0.02$$

$$\leq 0.50 \cdot \frac{f_{cd}}{f_{yd}} = 0.023$$

$$v_{Rd,c} = \frac{0.18}{1.5} \cdot 2.0 \cdot (100 \cdot 0.0140 \cdot 35)^{1/3}$$

$$v_{Rd,c} = 0.878 \text{ MN/m}^2 > v_{min}$$

$$< 1.208 \text{ MN/m}^2$$

⇒ punching reinforcement is required!

### Slab with punching reinforcement

### ▣ Maximum shear force

$$\begin{aligned} V_{Rd,max} &= 1.4 \cdot v_{Rd,c} = 1.4 \cdot 0.878 \\ &= 1.229 \text{ MN/m}^2 < V_{Ed} = 1.208 \text{ MN/m}^2 \end{aligned}$$

$$\Rightarrow V_{Ed} < V_{Rd,max} !$$

Punching reinforcement  $\alpha = 90^\circ$

$$u_{out} = \beta \cdot \frac{V_{Ed}}{v_{Rd,c} \cdot d}$$

$$u_{out} = 1.35 \cdot \frac{0.381}{0.878 \cdot \frac{0.15}{0.18} \cdot 0.19}$$

$$u_{out} = 3.69 \text{ m}$$

### ▣ Loaded area perimeter $A_{load}$

$$\begin{aligned} a_{out} &= \frac{u_{out} - u_o}{\pi} \\ &= \frac{3.69 - 3 \cdot 0.35}{\pi} = 0.84 \text{ m} \rightarrow \approx 4.42 \cdot d \end{aligned}$$

Punching reinforcement is required until  $(4.42 - 1.5) \cdot d = 2.92 \cdot d$

$$v_{Rd,s} = 0.75 + v_{Rd,c} + 1.5 \cdot \frac{d}{s_r} \cdot \frac{A_{sw} \cdot f_{ywd,ef} \cdot \sin \alpha}{u_1 \cdot d}$$

with

$$f_{ywd,ef} = 297 \text{ MN/m}^2$$

$$s_r = 0.5 \cdot d$$

$$A_{sw} = (v_{Ed} - 0.75 \cdot v_{Rd,c}) \cdot \frac{u_1 \cdot d}{1.5 \cdot \frac{d}{s_r} \cdot f_{ywd,ef}}$$

$$A_{sw} = (1.208 - 0.75 \cdot 0.878) \cdot \frac{2.24 \cdot 0.19 \cdot 10^4}{1.5 \cdot \frac{1}{0.5} \cdot 297}$$

$$A_{sw} = 2.62 \text{ cm}^2$$

Reinforcement in perimeter 1 -  $A_{sw,1}$

$$req A_{sw,1} = k_{sw} \cdot A_{sw}$$

$$req A_{sw,1} = 2.5 \cdot 2.62 = 6.55 \text{ cm}^2$$

Reinforcement in perimeter 2 -  $A_{sw,2}$

$$req A_{sw,2} = k_{sw} \cdot A_{sw}$$

$$req A_{sw,2} = 1.4 \cdot 2.62 = 3.66 \text{ cm}^2$$

$v_{Rd,max}$   
(NDP) 6.4.5(3) Eq.(NA.6.53.1)

(NCI) for 6.4.5 (4):  $v_{Rd,c}$  is used according 6.2.2 (1),  $C_{Rd,c} = \frac{0.15}{\gamma_c}$

(NCI), 9.4.3: Eq. (9.11DE)

$$A_{sw,min} = 0.26 \text{ cm}^2$$



## 32.5 Conclusion

The program searches for the single support nodes (single columns, wall ends as well as wall corners), and performs a punching check for these points. Nodes with less than 5 kN support reaction are not considered! Because the focus of the verification example is punching, the value  $\rho_l$  is overtaken from the verification example.

It has been shown that the results are reproduced with excellent accuracy.

## 32.6 Literature

- [1] *DIN EN 1992-1-1/NA: Eurocode 2: Design of concrete structures, Part 1-1/NA: General rules and rules for buildings - German version EN 1992-1-1:2005 (D), Nationaler Anhang Deutschland - Stand Februar 2010.* CEN. 2010.
  - [4] *Beispiele zur Bemessung nach Eurocode 2 - Band 1: Hochbau.* Ernst & Sohn. Deutschen Beton- und Bautechnik-Verein E.V. 2011.
-



## 33 DCE-EN32: Crack width calculation of reinforced slab acc. DIN EN 1992-1-1

### Overview

<b>Design Code Family(s):</b>	DIN
<b>Design Code(s):</b>	DIN EN 1992-1-1
<b>Module(s):</b>	BEMESS
<b>Input file(s):</b>	<a href="#">crack_width_slab_din-en-1992-1-1.dat</a>

### 33.1 Problem Description

The problem consists of a flat slab, reinforced, as shown in Fig. 33.1. Loading always consisting of a bending moment  $M_{Ed}$ , the normal force is  $N = 0$ . The crack width is determined.

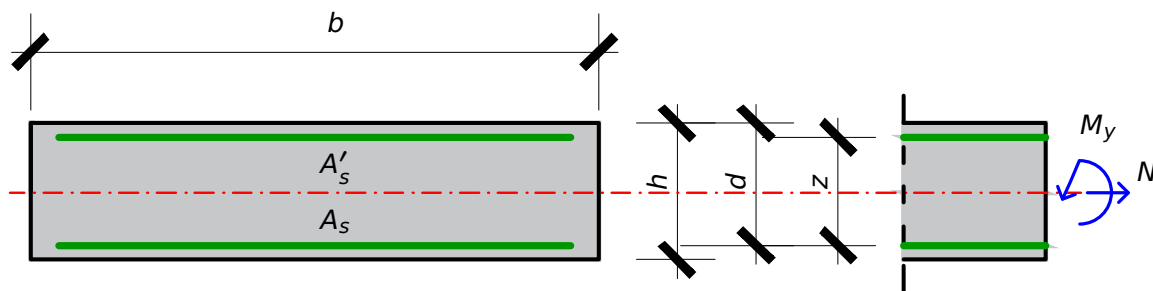

Figure 33.1: Geometry of slab,  $b = 1 \text{ m}'$

### 33.2 Reference Solution

This example is concerned with the control of crack widths. The content of this problem is covered by the following parts of DIN EN 1992-1-1:2004 [1]:

- Design stress-strain curves for concrete and reinforcement (Section 3.1.7, 3.2.7)
- Basic assumptions for calculation of crack widths (Section 7.3.2, 7.3.3, 7.3.4)

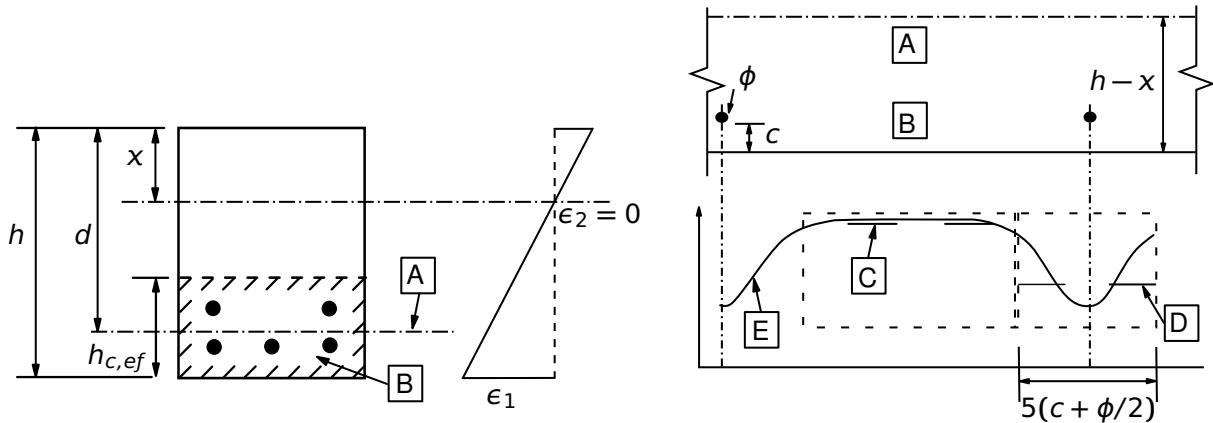

Figure 33.2: Stress and Strain Distributions in the Design of Cross-sections

The design stress-strain diagram for reinforcing steel considered in this example, consists of an inclined top branch, as defined in DIN EN 1992-1-1:2004 [1] (Section 3.2.7).

### 33.3 Model and Results

The slab, with properties as defined in Table 33.4, is to be designed for crack width, with respect to DIN EN 1992-1-1:2004 (German National Annex) [1] [2]. The calculation steps with different loading conditions and calculated with different sections of DIN EN 1992-1-1:2004 + NA are presented below and the results are given in Table 33.3.

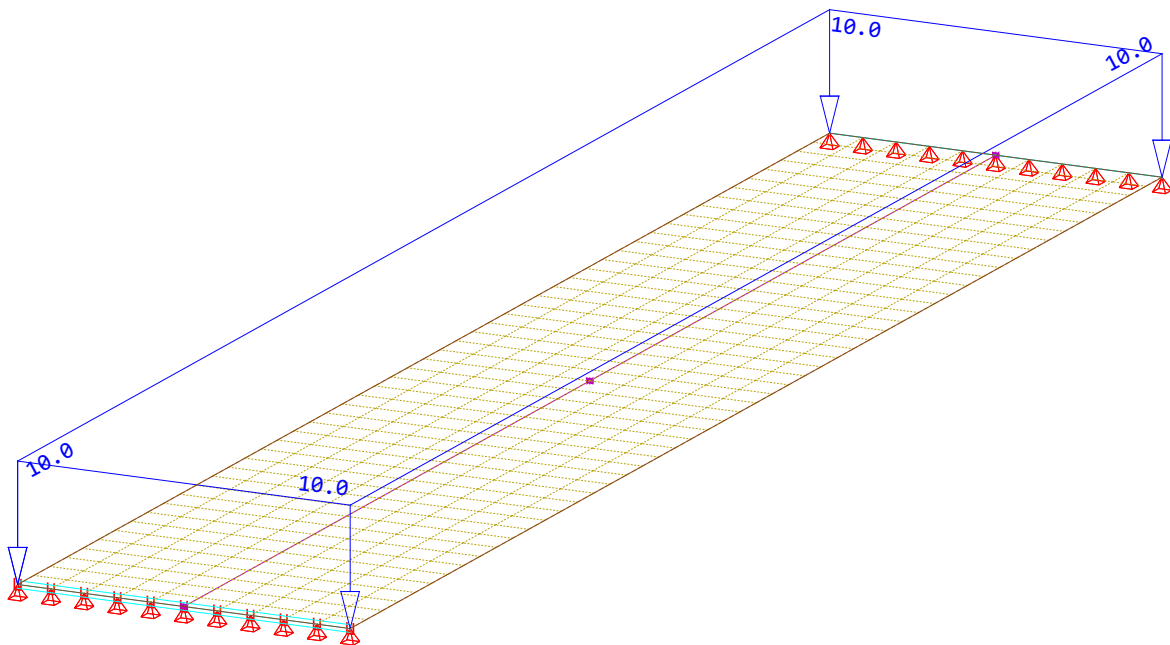

Figure 33.3: Model and Loading

Figure 33.4: Model and internal forces - design element -  $\gamma_G = 1.35$ 

Table 33.1: Model Properties

Material Properties	Geometric Properties	Loading
C 25/30	$h = 24.0 \text{ cm}$	$M_{Ed} = 42.11 \text{ kNm}$
B 500A	$d = 21 \text{ cm}$	
	$b = 1000.0 \text{ cm}$	
	$\phi_s = 10.0 \text{ mm}, a_s = 5.50 \text{ cm}^2/\text{m}'$	
	$\phi_{s'} = 10.0 \text{ mm}$	
	$w_{k,req} = 0.3 \text{ mm}$	

Table 33.2: Results - Crack width calculation WITHOUT direct method (quad element 10226)

Case	SOF.	REF.
$\sigma_{s,tab} [\text{MPa}]$	303.87	303.87
$\phi_s [\text{mm}]$	10	10
$\phi_s^* [\text{mm}]$	11.337	11.337
$\sigma_s [\text{MPa}]$	303.87	303.87
$a_s [\text{cm}^2/\text{m}]$	7.07	7.34

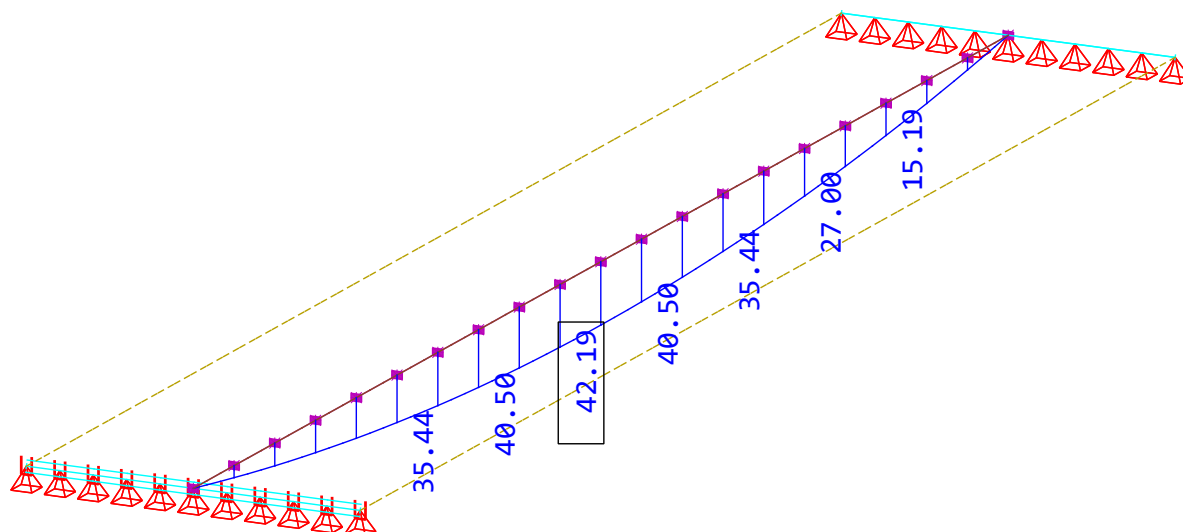
Table 33.3: Results - Crack width calculation with direct method (quad element 10226)

Case	SOF.	REF.
$a_s = 5.5 \text{ cm}^2/\text{m}'$	$w_k = 0.434 \text{ mm}$	$w_k = 0.434 \text{ mm}$
$w_{k,req} = 0.3 \text{ mm}$	$a_s = 6.59 \text{ cm}^2/\text{m}$	$a_s = 6.6 \text{ cm}^2/\text{m}'$

## 33.4 Design Process <sup>1</sup>

Design with respect to DIN EN 1992-1-1:2004 (NA) [1] [2]:<sup>2</sup>

### 33.4.1 Material

Concrete:  $\gamma_c = 1.50$

Steel:  $\gamma_s = 1.15$

$f_{ck} = 25 \text{ MPa}$

$f_{cd} = a_{cc} \cdot f_{ck} / \gamma_c = 0.85 \cdot 25 / 1.5 = 14.17 \text{ MPa}$

$f_{yk} = 500 \text{ MPa}$

$f_{yd} = f_{yk} / \gamma_s = 500 / 1.15 = 434.78 \text{ MPa}$

Design Load:

$M_{Ed} = 42.11 \text{ kNm}$

$N_{Ed} = 0.0$

### 33.4.2 Without direct calculation

$f_{ct,eff} = f_{ctm}$

$f_{ct,eff} = 2.56 \text{ MPa}$

$$\sigma_s = \frac{m_{Ed}}{a_s \cdot z}$$

$$\sigma_s = \frac{42.11 \cdot 10^{-3}}{5.5 \cdot 10^{-4} \cdot 0.9 \cdot 0.21} = 405.09 \text{ MPa}$$

$$\phi_s = \phi_s^* \cdot \frac{\sigma_s \cdot A_s}{4(h-d) \cdot b \cdot 2.9} \geq \phi_s^* \cdot \frac{f_{ct,eff}}{2.9}$$

$$\phi_s = 10 \text{ mm} = \phi_s^* \cdot \frac{405.09 \cdot 5.5}{4(24-21) \cdot 100 \cdot 2.9} = \phi_s^* \cdot 0.475$$

$$\phi_s = 10 = \phi_s^* \cdot 0.640 \geq \phi_s^* \cdot 0.882$$

$$\rightarrow \phi_s^* = \frac{\phi_s}{0.882} = \frac{10}{0.882} = 11.337 \text{ mm}$$

$$\sigma_{s,tab} = \sqrt{w_k \cdot 3.48 \cdot 10^6 / \phi_s^*}$$

$$\sigma_{s,tab} = \sqrt{0.3 \cdot 3.48 \cdot 10^6 / 11.337} = 303.448 \text{ MPa}$$

$$\sigma_{s,tab} = 303.448 < \sigma_s = 405.09 \text{ MPa}$$

→ crack width control is NOT passed with given reinforcement.

<sup>1</sup>The tools used in the design process are based on steel stress-strain diagrams, as defined in [1] 3.2.7:(2), Fig. 3.8.

<sup>2</sup>The sections mentioned in the margins refer to DIN EN 1992-1-1:2004 (German National Annex) [1], [2], unless otherwise specified.

(NDP) 2.4.2.4: (1), Tab. 2.1DE: Partial factors for materials

Tab. 3.1: Strength for concrete

3.1.6: (1)P, Eq. (3.15):  $a_{cc} = 0.85$  considering long term effects

3.2.2: (3)P: yield strength  $f_{yk} = 500 \text{ MPa}$

3.2.7: (2), Fig. 3.8

7.3.3: Control of cracking without direct calculation

Examples calculated in this section are w.r.t. Table 7.2DE, here Table 7.3N is not relevant

(NDP) 7.3.2 (2):  $f_{ct,eff}$  mean value of concrete tensile strength

Tab. 3.1:  $f_{ctm} = 2.6 \text{ MPa}$  for C 25

(NDP) 7.3.3: Eq. 7.7.1DE: The maximum bar diameters should be modified for load action

$A_s = 5.5 \text{ cm}^2$  prescribed reinforcement

(NDP) 7.3.3 Tab. 7.2DE (a)  
where  $w_k = 0.3 \text{ mm}$  the prescribed maximum crack width

$$a_{s,req} = \frac{m_{Ed}}{\sigma_{s,tab} \cdot z} \approx \frac{m_{Ed}}{\sigma_{s,tab} \cdot 0.9 \cdot d}$$

In BEMESS the lever arm is calculated by iterating the strains  $\epsilon_{top}$ ,  $\epsilon_{bot}$ ,  $\epsilon_c$ ,  $\epsilon_s$ . To simplify the reference  $\rightarrow z = 0.9 \cdot d$  is used.

$$a_{s,req} = \frac{42.11 \cdot 100}{30.3448 \cdot 0.9 \cdot 21} = 7.34 \text{ cm}^2/m'$$

### 33.4.3 With direct calculation

Given reinforcement  $a_s = 5.5 \text{ cm}^2/m'$

$$\sigma_s = \frac{m_{Ed}}{a_s \cdot z}$$

$$\sigma_s = \frac{42.11 \cdot 10^{-3}}{5.5 \cdot 10^{-4} \cdot 0.9 \cdot 0.21} = 405.09 \text{ MPa}$$

Effective area  $A_{c,eff}$  of concrete in tension surrounding the reinforcement :

7.3.2(3), Figure 7.1

$$A_{c,eff} = h_{c,eff} \cdot b$$

$$A_{c,eff} = (h - d) \cdot 2 \cdot b = (24 - 21) \cdot 2 \cdot 100 = 600 \text{ cm}^2$$

Crack width  $w_k$ , 7.3.4, Eq. 7.8

$$w_k = s_{r,max} \cdot (\epsilon_{sm} - \epsilon_{cm})$$

Crack width  $w_k$ , 7.3.4, Eq. 7.9

$$\epsilon_{sm} - \epsilon_{cm} = \frac{\sigma_s - k_t \cdot \frac{f_{ct,eff}}{\rho_{p,eff}} \cdot (1 + \alpha_e \cdot \rho_{p,eff})}{E_s} \geq 0.6 \cdot \frac{\sigma_s}{E_s}$$

7.3.4,  $k_t = 0.4$  for long term loading,  
 $k_t = 0.6$  for short term loading

$$k_t = 0.4$$

7.3.4, Eq. 7.10

$$\rho_{p,eff} = \frac{A_s + \xi_1^2 \cdot A'_p}{A_{c,eff}}$$

$$\alpha_e = \frac{E_s}{E_{cm}} = \frac{200000}{31476} = 6.354$$

$$A'_p = 0$$

7.3.4, Eq. 7.10

$$\rho_{p,eff} = \frac{A_s + \xi_1^2 \cdot A'_p}{A_{c,eff}} = \frac{A_s}{A_{c,eff}}$$

$$\rho_{p,eff} = \frac{5.5}{600} = 0.00916$$

Crack width  $w_k$ , 7.3.4, Eq. 7.9

$$\epsilon_{sm} - \epsilon_{cm} = \frac{405.09 - 0.4 \cdot \frac{2.56}{0.00916} \cdot (1 + 6.35 \cdot 0.00916)}{200000}$$

$$\frac{\sigma_s}{E_s} \cdot 0.6 = \frac{405.09}{200000} \cdot 0.6 = 0.00122$$

$$\epsilon_{sm} - \epsilon_{cm} = 0.00143 \geq 0.00122$$



$$s_{r,max} = \frac{\phi}{3.6 \cdot \rho_{p,eff}} \leq \frac{\sigma_s \cdot \phi}{3.6 \cdot f_{ct,eff}}$$

(NDP) 7.3.4 (3), Eq. 7.11

$$s_{r,max} = \frac{10}{3.6 \cdot 0.00917} \leq \frac{405.09 \cdot 10}{3.6 \cdot 2.56}$$

$$s_{r,max} = 303.03 \text{ mm} \leq 439 \text{ mm}$$

$$w_k = s_{r,max} \cdot (\epsilon_{sm} - \epsilon_{cm}) = 303.03 \cdot 0.00143$$

$$w_k = 0.43 \text{ mm} \geq w_{req} = 0.30 \text{ mm}$$

→ Check for crack is NOT passed with given reinforcement

The steps are now iterated and the reinforcement will be increased until  $w_k = w_{req} = 0.3 \text{ mm}$ .

Table 33.4: Iteration

$a_s$ [ $\text{cm}^2/\text{m}$ ]	$\sigma_s$ [MPa]	$w_k$ [mm]
5.5	405.0986051	0.434
5.6	397.86	0.419
5.7	390.88	0.404
5.8	384.15	0.390
5.9	377.63	0.377
6.0	371.34	0.364
...	...	...
<b>6.6</b>	<b>337.58</b>	<b>0.300</b>

Calculation steps for given reinforcement  $a_s = 6.6 \text{ cm}^2/\text{m}$

$$\sigma_s = 337.58 \text{ MPa}$$

$$A_{c,eff} = h_{c,eff} \cdot b$$

7.3.2(3), Figure 7.1

$$A_{c,eff} = (h - d) \cdot 2 \cdot b = (24 - 21) \cdot 2 \cdot 100 = 600 \text{ cm}^2$$

$$w_k = s_{r,max} \cdot (\epsilon_{sm} - \epsilon_{cm})$$

Crack width  $w_k$ , 7.3.4, Eq. 7.8

$$\epsilon_{sm} - \epsilon_{cm} = \frac{\sigma_s - k_t \cdot \frac{f_{ct,eff}}{\rho_{p,eff}} \cdot (1 + \alpha_e \cdot \rho_{p,eff})}{E_s} \geq 0.6 \cdot \frac{\sigma_s}{E_s}$$

Crack width  $w_k$ , 7.3.4, Eq. 7.9

$$k_t = 0.4$$

7.3.4,  $k_t = 0.4$  for long term loading,  $k_t = 0.6$  for short term loading

$$\rho_{p,eff} = \frac{A_s + \xi_1^2 \cdot A'_p}{A_{c,eff}}$$

7.3.4, Eq. 7.10

$$\alpha_e = \frac{E_s}{E_{cm}} = \frac{200000}{31476} = 6.354$$

7.3.4,  $\alpha_e$  is the ratio  $E_s/E_{cm}$ 

$$A'_p = 0$$

$$\rho_{p,eff} = \frac{A_s + \xi_1^2 \cdot A'_p}{A_{c,eff}} = \frac{A_s}{A_{c,eff}}$$

$$\rho_{p,eff} = \frac{6.6}{600} = 0.0110$$

7.3.4, Eq. 7.9

$$\varepsilon_{sm} - \varepsilon_{cm} = \frac{337.58 - 0.4 \cdot \frac{2.56}{0.0110} \cdot (1 + 6.35 \cdot 0.0110)}{200000}$$

$$\frac{\sigma_s}{E_s} \cdot 0.6 = \frac{337.58}{200000} \cdot 0.6 = 0.00101$$

$$\varepsilon_{sm} - \varepsilon_{cm} = 0.0011899 \geq 0.00101$$

(NDP) 7.3.4 (3), Eq. 7.11

$$s_{r,max} = \frac{\phi}{3.6 \cdot \rho_{p,eff}} \leq \frac{\sigma_s \cdot \phi}{3.6 \cdot f_{ct,eff}}$$

$$s_{r,max} = \frac{10}{3.6 \cdot 0.0110} \leq \frac{337.58 \cdot 10}{3.6 \cdot 2.56}$$

$$s_{r,max} = 252.52 \text{ mm} \leq 366.30 \text{ mm}$$

$$w_k = s_{r,max} \cdot (\varepsilon_{sm} - \varepsilon_{cm}) = 252.52 \cdot 0.0011899$$

$$w_k = 0.30 \text{ mm} \leq w_{req} = 0.30 \text{ mm}$$

→ Check for crack is passed with given reinforcement

### 33.5 Conclusion

This example shows the calculation of crack widths. Various ways of reference calculations are demonstrated, in order to compare the SOFiSTiK results to. It has been shown that the results are reproduced with excellent accuracy.

### 33.6 Literature

- [1] *DIN EN 1992-1-1/NA: Eurocode 2: Design of concrete structures, Part 1-1/NA: General rules and rules for buildings - German version EN 1992-1-1:2005 (D), Nationaler Anhang Deutschland - Stand Februar 2010.* CEN. 2010.
  - [2] F. Fingerloos, J. Hegger, and K. Zilch. *DIN EN 1992-1-1 Bemessung und Konstruktion von Stahlbeton- und Spannbetontragwerken - Teil 1-1: Allgemeine Bemessungsregeln und Regeln für den Hochbau.* BVPI, DBV, ISB, VBI. Ernst & Sohn, Beuth, 2012.
-



## 34 DCE-EN33: Designing a Reinforced Concrete Column acc. DIN EN 1992-1-1

### Overview

<b>Design Code Family(s):</b>	DIN
<b>Design Code(s):</b>	DIN EN 1992-1-1
<b>Module(s):</b>	COLUMN
<b>Input file(s):</b>	<a href="#">column_din_en_1992_nkv.dat</a>

### 34.1 Problem Description

The problem consists of a reinforced concrete column positioned at edge of the building, as shown in Fig. 34.1. Different loading conditions and the design approach by using the *nominal curvature* method are examined.

The main goal of this benchmark is to verify and compare the SOFiSTiK results with the reference example *Beispiele zur Bemessung nach Eurocode 2 - Band 1: Hochbau* [4, Example 10]. In this example the **Ultimate Limit State** (ULS) of the prefabricated column is verified.

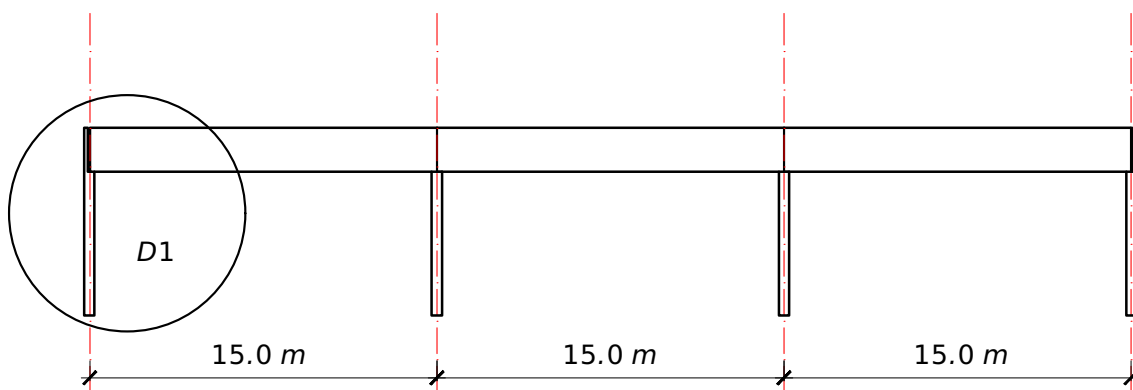

Figure 34.1: Column D1

### 34.2 Reference Solution

This example is concerned with the design of reinforced concrete column. The content of this problem is covered by following parts of DIN EN 1992-1-1:2004 [1]:

- Concrete cover (Section 4.4.1.1 and (NDP) Tab. 4.4DE)
- Materials (Section 3.1 and 3.2)
- Analysis of second order effects with axial load (Section 5.8)
- Geometric imperfections (Section 5.2)
- Columns (Section 9.5)

- Shear (Section 6.2.2)

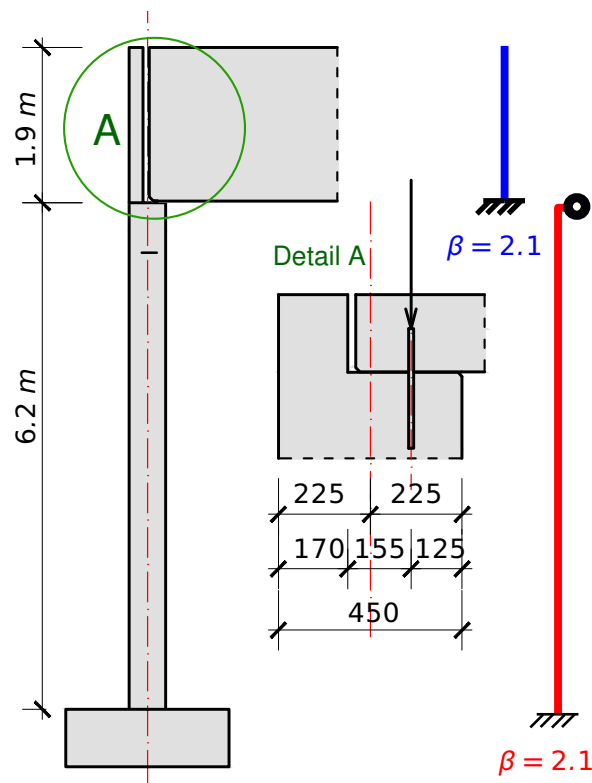

Figure 34.2: Column properties

The design stress-strain diagram for reinforcing steel considered in this example, consists of an inclined top branch, as defined in DIN EN 1992-1-1:2004 [1] (Section 3.2.7).

### 34.3 Model and Results

The column, with properties as defined in Table 34.1, is to be designed for ultimate limit state, with respect to DIN EN 1992-1-1:2004 (German National Annex) [1] [2]. The calculation steps with loading conditions are presented below and the results are given in Table 34.3.

Table 34.1: Model Properties

Material Properties	Geometric Properties	Loading
C 30/37	$b_1/h_1 = 45/40 \text{ cm}$	$G_k = 431.0 \text{ kN}$
B 500B	$b_2/h_2 = 17/40 \text{ cm}$	$Q_{k,s} = 68.0 \text{ kN}$
	$d_y = 41 \text{ cm}$	$q_{k,w1} = +4.32 \text{ kN/m}$
	$h = 6.20 + 1.9 = 8.1 \text{ m}$	$q_{k,w2} = -1.85 \text{ kN/m}$

Table 34.2: Results

	Units	SOF.	Ref.
$N$	[kN]	-633.0	-633.0
$M_y$	[kNm]	100.28	100.0
$M_z$	[kNm]	0.0	0.0
$e_0$	[mm]	158.4 <sup>1</sup>	179.0
$e_1$	[mm]	20.7	21.0
$A_{s,req,1}$	[cm <sup>2</sup> ]	15.45 <sup>1</sup>	16.20
$A_{s,req,2}$	[cm <sup>2</sup> ]	4.52	4.52

<sup>1</sup>See conclusion (Section 34.5) for more details why the results are different compared to the reference example.

## 34.4 Design Process <sup>1</sup>

Design with respect to DIN EN 1992-1-1:2004 (NA) [1] [2]:<sup>2</sup>

### 34.4.1 Exposure class

For concrete inside buildings with low air humidity → XC1

Min. concrete class → C 16/20

Chosen concrete class → C 37/30

$$c_{nom} = c_{min} + c_{dev}$$

$$c_{nom} = 10 + 10 = 20 \text{ mm}$$

$c_{nom}$  is the nominal concrete cover between the surface of the reinforcement closest to the nearest concrete surface, 4.4.1.1, Eq. (4.1)

### 34.4.2 Actions

#### Dead loading

$$G_{k,1} = 400 \text{ kN}$$

$$G_{k,2,1} = 0.40 \text{ m} \cdot 0.45 \text{ m} \cdot 6.20 \text{ m} \cdot 25 \text{ kN/m}^3 = 27.9 \text{ kN}$$

$$G_{k,2,2} = 0.40 \text{ m} \cdot 0.17 \text{ m} \cdot 1.90 \text{ m} \cdot 25 \text{ kN/m}^3 = 3.2 \text{ kN}$$

---

$$\sum G_{k,i} = 431 \text{ kN}$$

#### Variable loading

Snow:  $Q_{k,s} = 68 \text{ kN}$

Wind:  $w_e = c_{pe} \cdot q(z_e)$

$$q_{k,w,1} = +0.7 \cdot 0.95 = +0.665 \text{ kN/m}^2$$

$$q_{k,w,2} = -0.3 \cdot 0.95 = -0.285 \text{ kN/m}^2$$

Distance between columns is  $a = 6.5 \text{ m}$

### 34.4.3 Materials

#### Concrete

Class C 30/37

$$\gamma_c = 1.50$$

$$f_{ck} = 30 \text{ MPa}$$

$$f_{cd} = a_{cc} \cdot f_{ck} / \gamma_c = 0.85 \cdot 30 / 1.5 = 17.0 \text{ MPa}$$

(NDP) 2.4.2.4: (1), Tab. 2.1DE: Partial factors for materials

Tab. 3.1: Strength for concrete

3.1.6: (1)P, Eq. (3.15):  $a_{cc} = 0.85$  considering long term effects

<sup>1</sup>The tools used in the design process are based on steel stress-strain diagrams, as defined in [1] 3.2.7:(2), Fig. 3.8.

<sup>2</sup>The sections mentioned in the margins refer to DIN EN 1992-1-1:2004 (German National Annex) [1], [2], unless otherwise specified.



## Steel

Class B 500B

$$\gamma_s = 1.15$$

$$f_{yk} = 500 \text{ MPa}$$

$$f_{yd} = f_{yk}/\gamma_s = 500/1.15 = 434.78 \text{ MPa}$$

3.2.2: (3)P: yield strength  $f_{yk} = 500 \text{ MPa}$

3.2.7: (2), Fig. 3.8

### 34.4.4 Buckling length

Buckling length around the y-axis:

$$l_{0,y} = \beta_y \cdot l_{col}$$

$$l_{col} = 6.20 \text{ m}$$

$$\beta_y = 2.1 \leftarrow \text{approximated}$$

$$l_{0,y} = 6.2 \cdot 2.1 = 13.0 \text{ m}$$

$$\lambda_y = \frac{l_{y,0}}{i_y} = 13.0 \cdot \sqrt{12}/0.45 = 100$$

$l_{col}$ , height of the column between the idealized fixing points.

$\beta_y$ , buckling factor

$\lambda_y$ , slenderness

Buckling length around the z-axis:

$$l_{0,z} = \beta_z \cdot l_{col}$$

$$l_{col} = 6.20 \text{ m}$$

$$\beta_z = 1.0 \leftarrow \text{pinned on both sides}$$

$$l_{0,z} = 6.2 \cdot 1.0 = 6.2 \text{ m}$$

$$\lambda_z = \frac{l_{z,0}}{i_z} = 6.2 \cdot \sqrt{12}/0.40 = 54$$

$l_{col}$ , height of the column between the idealized fixing points.

$\beta_z$ , buckling factor

$\lambda_z$ , slenderness

Slenderness criterion for isolated member

$$n = \frac{N_{Ed}}{A_c \cdot f_{cd}} = \frac{0.684}{0.40 \cdot 0.45 \cdot 17.0} = 0.224$$

$n$  is the relative normal force, (NDP) 5.8.3.1 (1)

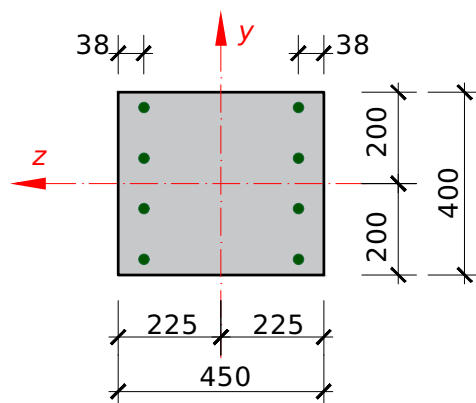

Figure 34.3: Column properties

$$\lambda_{lim} = \frac{16}{\sqrt{n}} = \frac{16}{0.224} = 34 \text{ for } n = 0.224 < 0.41$$

5.8.3.1(2)

Because  $\lambda_y = 100$  and  $\lambda_z$  are  $> \lambda_{lim} = 34$  second order effects should be taken into account in both directions (y and z).

### 34.4.5 Imperfections

For isolated members, the effect of imperfection may be taken into account:

$e_i$  is the eccentricity acc. 5.2(7), a) Eq. (5.2)

$$e_i = \theta \cdot \frac{l_0}{2}$$

$\theta$  is the inclination value acc. Eq. (5.1)

$$\theta = \theta_0 \cdot \alpha_h \cdot \alpha_m$$

$\theta_0$  is the basic inclination value, Eq. (5.1)

$$\theta_0 = \frac{1}{200}$$

$\alpha_h$  is the reduction factor for length of the height

$$\alpha_h = \frac{2}{\sqrt{l}} = \frac{2}{\sqrt{6.2}} = 0.803 < 1.0$$

$$\alpha_m = \sqrt{0.5 \cdot (1 + 1/m)} = \sqrt{0.5 \cdot (1 + 1/4)} = 0.79$$

Bending about the y-axis:

$$l_{0,y} = 13.00 \text{ m}$$

$$\theta_i = 0.803 \cdot 0.79 \cdot \frac{1}{200} = 0.00317 = 1/315$$

$$e_{a,z} = \frac{13000}{2 \cdot 315} = 21 \text{ mm}$$

Bending about the z-axis:

$$l_{0,z} = 6.20 \text{ m}$$

$$\theta_i = 0.803 \cdot 1.0 \cdot \frac{1}{200} = 0.00402 \approx 1/250$$

$$e_{a,y} = \frac{6200}{2 \cdot 250} = 13 \text{ mm}$$

### 34.4.6 Min. and max. required reinforcement

(NDP) 9.5.2, maximum value of  $0.09 A_c$  should not be exceeded.

$$A_{s,max} = 0.09 \cdot 40 \cdot 45 = 162 \text{ cm}^2$$

$$A_{s,min} = 0.15 \cdot \frac{|N_{Ed}|}{f_{yd}} = 10^4 \cdot 0.15 \cdot 0.684/435 = 2.35 \text{ cm}^2$$

$$\text{Constructive: } 6 \phi 12: A_{s,min} = 6.79 \text{ cm}^2$$

### 34.4.7 Design of longitudinal reinforcement

#### Nominal curvature method for y-y direction

The design is approached by using the nominal curvature method. This method is primarily suitable for isolated members with constant normal force and a defined effective length  $l_0$ . The method gives a nominal

second order moment based on a deflection, which in turn is based on the effective length and an estimated maximum.

Design moment  $M_{Ed}$ :

$$M_{Ed} = M_{0Ed} + M_2 = N_{Ed} \cdot (e_0 + e_i + e_2)$$

$$K_1 = 1 \text{ for } \lambda > 35$$

$$n_u = 1 + \omega = 1 + \frac{f_{cd} \cdot A_c}{f_{yd} \cdot A_s}$$

In the reference example  $A_s = 25.1 \text{ cm}^2$  value is roughly estimated. The formula for  $\omega$  value is NOT correct.

In SOFiSTiK we use  $\omega = \frac{f_{yd} \cdot A_s}{f_{cd} \cdot A_c}$

$$n_u = 1 + \frac{17.0 \cdot 0.40 \cdot 0.45}{435 \cdot 25.1 \cdot 10^{-4}}$$

$$n_u = 1 + \frac{3.06}{1.09} = 3.81$$

$$n_{bal} = 0.4$$

$$\varepsilon_{yd} = \frac{f_{yd}}{E_s} = \frac{435}{200000} = 2.175 \cdot 10^3$$

$n_{bal}$  is the value of  $n$  at maximum moment resistance, the value 0.4 may be used, 5.8.8.3

statical height:

$$d = h - c_{v,s} - \phi_{v,s} - \frac{\phi_l}{2}$$

$$d = 450 - 20 - 10 - \frac{16}{2} \approx 410 \text{ mm}$$

Cross-section:  $b/h/d = 400/450/410 \text{ mm}$

$$\frac{d_1}{h} = \frac{(450 - 410)}{450} = 0.09 \approx 0.10$$

Table 34.3: Results

Value	Units	Comb 1	Comb 2	Comb 3
$M_y$	[kN]	74.40	90.40	100.00
$N$	[kN]	-684.00	-431.00	-633.00
$e_0$	[mm]	109	210	158
$e_1$	[mm]	21	21	21
$e_0 + e_i$ [mm]	[mm]	130	231	179
$n$		0.224	0.141	0.207
$K_r$		1	1	1

Table 34.3: (continued)

Value	Units	Comb 1	Comb 2	Comb 3
$e_2 = K_1 \cdot \frac{1}{r} \cdot \frac{l_0^2}{10}$	[mm]	199	199	199
$e_{tot} = e_0 + e_i + e_2$	[mm]	329	430	378
$M_{Ed} = N_{Ed} \cdot e_{tot}$	[kNm]	225	185	239
$\mu_{Ed} = M_{Ed} / (b \cdot d^2 \cdot f_{cd})$		0.16	0.13	0.174
$\omega_{tot}$		0.19	0.13	0.174
$A_{s,tot} = \omega_{tot} \cdot b \cdot h \cdot \frac{f_{cd}}{f_{yd}}$	[cm <sup>2</sup> ]	13.40	12.70	16.20

### Creep and shrinkage

$\phi(\infty, t_0)$ , 3.1.4, Fig. 3.1 a)

$$\phi_{ef} = \phi(\infty, t_0) \cdot \frac{M_{0Eqp}}{M_{0Ed}}$$

$$K_{f\phi} = 1 + \beta \cdot \phi_{ef} \geq 1.0$$

$$\beta = 0.35 + \frac{f_{ck}}{200} - \frac{\lambda}{150} \geq 0$$

$$\beta = 0.35 + \frac{300}{200} - \frac{100}{150} = -0.17 < 0$$

$K_{\phi} = 1 \rightarrow$  Creep and shrinkage is neglected!

### Nominal curvature method for z-z direction

The column will be designed as a non-reinforcement column for z-z direction:

Buckling length:

$$l_{0,z} = 6.20 \text{ m}$$

Slenderness:

$$\lambda_z = 54 < \lambda_{max} = 86$$

Limits for the second order theory:

$$\frac{l_{col}}{h} = \frac{6.20}{0.40} = 15.50 > 2.5$$

The column should be investigated for the second order effects.

Design resistance normal force  $N_{Rd}$ :

$$N_{Rd} = b \cdot h_w \cdot f_{cd,pl} \cdot \Phi$$

$$\Phi = 1.14 \cdot \left(1 - 2 \cdot \frac{e_{tot}}{h_w}\right) - 0.02 \cdot \frac{l_0}{h_w} \leq 1 - \frac{2 \cdot e_{tot}}{h}$$

$\Phi$  is the factor taking into account eccentricity, including 2nd order effects and normal effects of creep, 12.6.5.2

$h_w$  is the overall depth of the cross-section, 12.6.5.2

$b$  is the overall width of the cross-section, 12.6.5.2

$$e_{tot} = e_0 + e_i = 0 + 13 = 13 \text{ mm}$$

$$\Phi = 1.14 \cdot \left(1 - 2 \cdot \frac{13}{400}\right) - 0.02 \cdot \frac{6200}{400} \leq 1 - \frac{2 \cdot 13}{400}$$

$$\Phi = 0.756 \leq 0.94$$

$$f_{cd,pl} = \frac{0.70 \cdot 30}{1.5} = 14.0 \text{ N/mm}^2$$

$$N_{Rd} = 0.45 \cdot 0.40 \cdot 14.0 \cdot 0.756 = 1.9 \text{ sMN} > |N_{Ed}| = 0.684 \text{ MN}$$

### 34.4.8 Design of shear reinforcement

Shear design on bottom of column:

$$V_{Ed} = -32.0 \text{ kN}$$

General verification procedure, 6.2.1

$$N_{Ed} = 431 \text{ kN}$$

$$d = 0.41 \text{ m}$$

$$V_{Ed,ref} = 32.0 - 0.41 \cdot 6.48 = 29.3 \text{ kN}$$

The design value of the shear resistance  $V_{Rd,c}$

$$V_{Rd,c} = \left[ \frac{0.15}{\gamma_c} \cdot k \cdot (100 \cdot \rho_l \cdot f_{ck})^{1/3} + 0.12 \cdot \sigma_{cp} \right] \cdot b_w \cdot d > V_{Rd,c,min}$$

Shear design, 6.2.2, Eq. (6.2)

$$k = 1 + \sqrt{\frac{200}{d}} \leq 2.0$$

$$k = 1 + \sqrt{\frac{200}{410}} = 1.70$$

$$\rho_l = \frac{A_{sl}}{b_w \cdot d} = \frac{8.04}{40 \cdot 41} = 0.0049 < 0.02$$

$$f_{ck} = 30 \text{ N/mm}^2$$

$$\sigma_{cp} = \frac{N_{Ed}}{A_c} = \frac{0.431}{0.40 \cdot 0.45} = 2.39 \text{ MN/m}^2$$

C30/37 →  $0.2 \cdot f_{cd} = 3.4 \text{ MPa}$

$$V_{Rd,c} = \left[ \frac{0.15}{1.5} \cdot 1.70 \cdot (100 \cdot 0.49 \cdot 30)^{1/3} + 0.12 \cdot 2.39 \right] \cdot 0.40 \cdot 0.41 > 0.115 \text{ MN}$$

$$V_{Ed,red} = 29.3 \text{ kN} < V_{Rd,c} = 115 \text{ kN}$$

→ no shear reinforcement required!

## 34.5 Conclusion

This example shows the calculation of column design by using the nominal curvature method. Various ways of reference calculations are demonstrated, in order to compare the reference results to SOFiSTiK.

The main reason for minor deviations (See Tab. 34.3 in Section 34.3) is that in the reference benchmark, the 2nd order effects and the reinforcement are approximated by using analytical formulas. In SOFiSTiK, the  $K_r$  value is iterated until  $K_r < 1 \cdot 10^{-4}$ , if this condition is met, then the iteration is stopped. With a hand calculation this is very difficult to achieve.

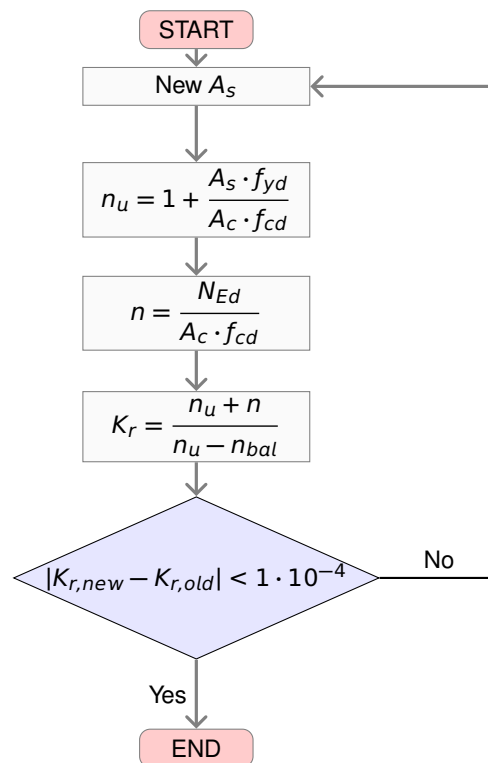

Figure 34.4: Iteration

The general approach of the nominal curvature is listed as following steps:

1. Calculation of the imperfection  $e_i$ , slenderness  $\lambda$  and inner lever arm  $d_{y,z}$
2. Find the critical deflection  $e_0$ , which depends on the current loadcase combination. Consider different end-moments according EN 1992-1-1:2004, 5.8.8.2 (2), Eq. 5.32
3. Start iteration of design moment  $M_{Ed}$  (Theory II. Order). The iteration will stop, when the coefficient  $K_r$  achieved convergence.
  - (a) Validation, if uni-/biaxial design can be applied
  - (b) Calculate the coefficient  $K_r$  and the eccentricity  $e_2$
  - (c) Calculate actual design moment  $M_{Ed} = N_{Ed} \cdot (e_0 + e_i + e_2)$
  - (d) Calculate required reinforcement with the program AQB
4. Additional cross section design on different locations (without imperfection and theory II.O.)
5. Result: decisive design moment, required reinforcement and utilization factor.

## 34.6 Literature

- [1] *DIN EN 1992-1-1/NA: Eurocode 2: Design of concrete structures, Part 1-1/NA: General rules and rules for buildings - German version EN 1992-1-1:2005 (D), Nationaler Anhang Deutschland - Stand Februar 2010.* CEN. 2010.
  - [2] F. Fingerloos, J. Hegger, and K. Zilch. *DIN EN 1992-1-1 Bemessung und Konstruktion von Stahlbeton- und Spannbetontragwerken - Teil 1-1: Allgemeine Bemessungsregeln und Regeln für den Hochbau.* BVPI, DBV, ISB, VBI. Ernst & Sohn, Beuth, 2012.
  - [4] *Beispiele zur Bemessung nach Eurocode 2 - Band 1: Hochbau.* Ernst & Sohn. Deutschen Beton- und Bautechnik-Verein E.V. 2011.
-





## 35 DCE-EN34: Elastic Critical Plate Buckling Stress

### Overview

<b>Design Code Family(s):</b>	EN
<b>Design Code(s):</b>	EN 1993-1-1
<b>Module(s):</b>	ASE
<b>Input file(s):</b>	<a href="#">eccs_plate_buckling.dat</a>

### 35.1 Problem Description

The problem consists of a stiffened steel plate. Its dimensions and boundary conditions are given in Figure 35.2.

The main goal of this benchmark is to verify and compare the SOFiSTiK results with the ECCS reference example Beg et al. [22, Example 2.4-3].

In SOFiSTiK a FEM model will be used to compare the results with:

- Klöppel diagrams (Klöppel and Scheer, 1960)
- EBPlate (2007)
- FEM software (ABAQUS)
- EN 1993-1-5 rules

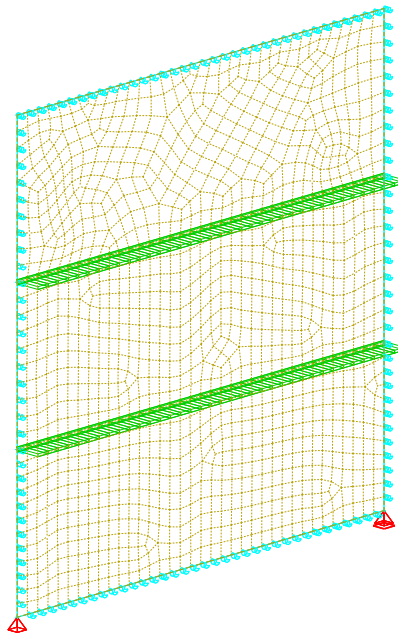
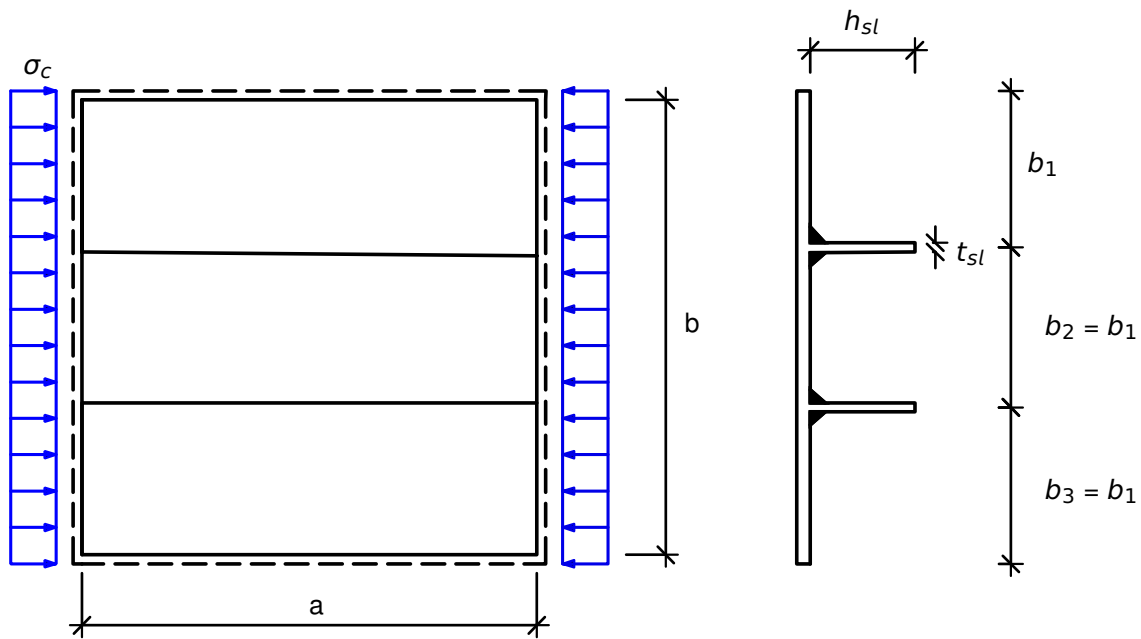

Figure 35.2: SOFiSTiK FEM Model - Steel plate with 2 horizontal stiffeners



$a = 1800 \text{ mm}$ ,  $b = 1800 \text{ mm}$ ,  $b_1 = 600 \text{ mm}$ ,  $h_{sl} = 100 \text{ mm}$ ,  $t_{sl} = 10 \text{ mm}$ .  
 S 355,  $f_y = 355 \text{ N/mm}^2$ ,  $\varepsilon = 0.81$

Figure 35.1: The layout of stiffened plate

## 35.2 Reference Solution

This example is concerned with calculation of the elastic critical plate buckling stress. The content of this problem is covered by following parts of EN 1993-1-1 [7] and EN 1993-1-5 [23]:

- Materials (EN 1993-1-1 [7], Section 3)
- Calculating the critical plate buckling stress (EN 1993-1-5 [23], Annex A.2)

## 35.3 Model and Results

The calculation steps with loading conditions are presented below and the results are given in Table 35.2.

To calculate the critical plate buckling stress the loading,  $\sigma_c = 1.0 \text{ N/mm}^2$  is used. The critical elastic stress will be calculated by multiplying the minimum eigenvalue with the unity stress  $\sigma_c = 1.0$ .

$$\sigma_{cr,p} = \alpha_{cr} \cdot \sigma_c$$

Table 35.1: Model Properties

Material Properties	Geometric Properties	Loading
S 355	$a = 1800 \text{ mm}$	$\sigma_c = -1 \text{ N/mm}^2$
$f_y = 355 \text{ N/mm}^2$	$b = 1800 \text{ mm}$	
$\varepsilon = 0.81$	$b_1 = 600 \text{ mm}$	

Table 35.1: (continued)

Material Properties	Geometric Properties	Loading
	$h_{sl} = 100 \text{ mm}$	
	$t_{sl} = 10 \text{ mm}$	
	$t = 12 \text{ mm}$	

Table 35.2: Results

Units	SOF.	Klöppel	EBPlate	ABAQUS	EN 1993-1-5
$\sigma_{cr} \left[ \frac{N}{\text{mm}^2} \right]$	275.782	274.170	268.72 <sup>1</sup>	268 <sup>2</sup>	290

Table 35.3: SOFiSTiK Buckling Eigenvalues

No.	Loadcase	Relative Error	Buckling Factor
1.	2001	2.03E-21	<b>275.782</b>
2.	2002	4.65E-16	324.372
3.	2003	3.77E-11	350.856
4.	2004	8.56E-10	361.965
5.	2005	1.38E-09	375.972

<sup>1</sup>EBPlate, V2.01<sup>2</sup>The results were overtaken from the ECCs reference example Beg et al. [22, Example 2.4-3]

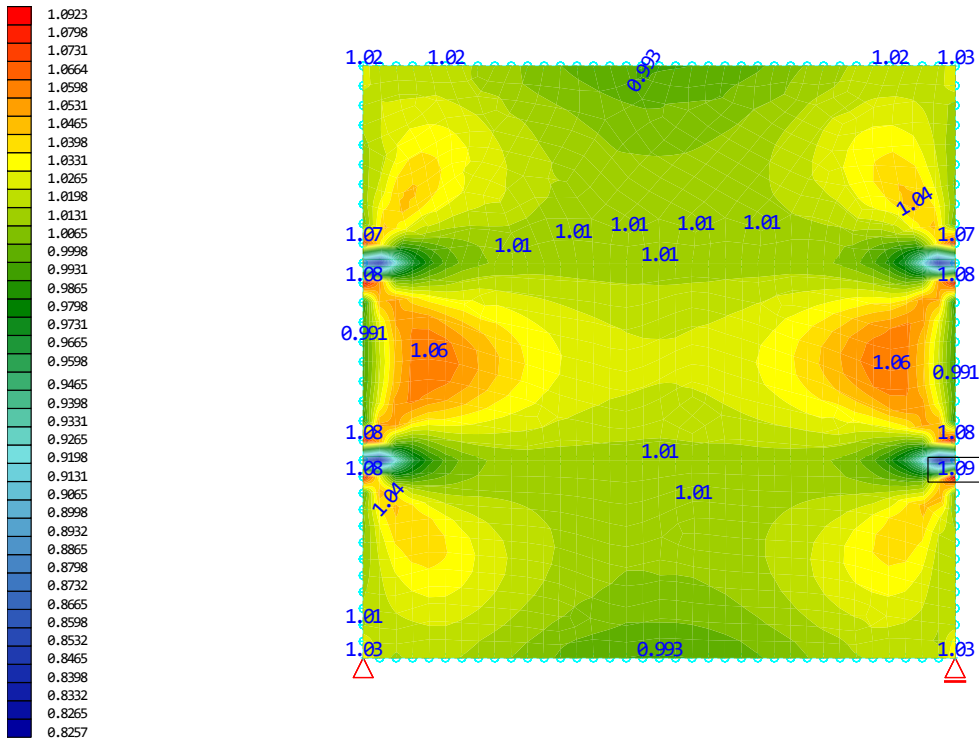

Figure 35.3: SOFiSTiK FEM Model - Stress distribution along the plate for  $\sigma_c = 1.0 \text{ N/mm}^2$

## 35.4 Design Process

Design with respect to EN 1993-1-5:2006 [23]:<sup>3</sup>

### 35.4.1 Klöppel

$\sigma_{cr,p}$  is given with the following equation:

$$\sigma_{cr,p} = k_{\sigma,p} \cdot \sigma_E$$

Where:

$$\sigma_E = \frac{\pi^2 \cdot E \cdot t^2}{12 \cdot (1 - \nu^2) \cdot b^2}$$

$$\sigma_E = \frac{\pi^2 \cdot 210000 \cdot 12^2}{12 \cdot (1 - 0.3^2) \cdot 1800^2} = 8.436 \text{ N/mm}^2$$

$k_{\sigma,p}$  is the elastic critical plate buckling coefficient according to Klöppel.

The parameters needed for the evaluation of  $k_{\sigma,p}$  are:

$$\alpha = \frac{a}{b} = \frac{1800}{1800} = 1.0$$

$$\delta = \frac{A_{sl}}{b \cdot t} = \frac{b_{sl} \cdot t}{b \cdot t} = \frac{100 \cdot 10}{1800 \cdot 12} = 0.05$$

$$\gamma = \frac{(I_{sl} + A_{sl} \cdot e^2) \cdot 12 \cdot (1 - \nu^2)}{b \cdot t^3}$$

$$\gamma = \frac{\left( b_{sl}^3 \cdot \frac{t_{sl}}{12} + b_{sl} \cdot t_{sl} \cdot e^2 \right) \cdot 12 \cdot (1 - \nu^2)}{b \cdot t^3}$$

$$\gamma = \frac{\left( 100^3 \cdot \frac{10}{12} + 100 \cdot 10 \cdot 50^2 \right) \cdot 12 \cdot (1 - 0.3^2)}{1800 \cdot 12^3} = 11.70$$

Note that parameter  $\alpha$  and  $\delta$  above are not the same as in EN 1993-1-5, Annex A.1, where the procedure for plates stiffened with more than two stiffeners is given.

The plate buckling coefficient is obtained from the diagram (according to Klöppel) in Figure 35.4.

$$k_{\sigma} = 32.5$$

Finally, the critical buckling stress is equal to:

$$\sigma_{cr,p} = k_{\sigma} \cdot \sigma_E = 32.5 \cdot 8.436 = 274.17 \text{ N/mm}^2$$

### 35.4.2 EBPlate

The usual procedure (calculation of buckling modes) for the calculation of critical stresses is presented by using EBPlate.

<sup>3</sup>The sections mentioned in the margins refer to EN 1993-1-5:2006 [23] unless otherwise specified.

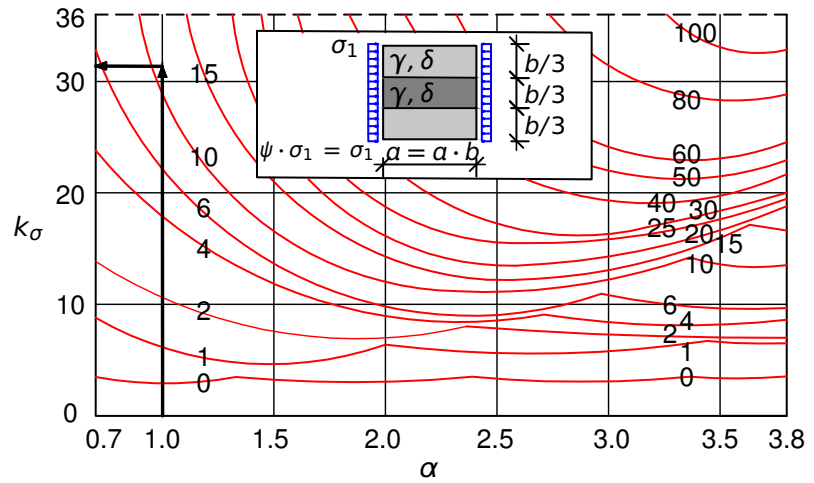

Figure 35.4: Klöppel Diagram

plate:  $a = 1800 \text{ mm}$ ,  $b = 1800 \text{ mm}$ ,  $t = 12 \text{ mm}$

stiffener:  $h = b_{sl} = 100 \text{ mm}$ ,  $t = t_{sl} = 10 \text{ mm}$

stiffener position:  $b_1 = 600 \text{ mm}$

**Results (1st and 2nd buckling mode)**

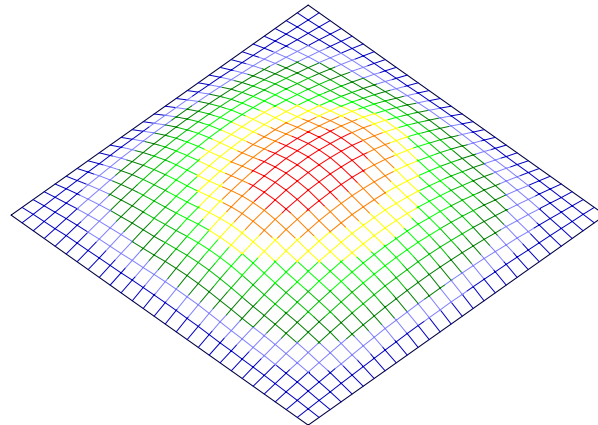

Figure 35.5: EBPlate - Buckling mode 1,  $\sigma_{cr,p} = 268.72 \text{ N/mm}^2$

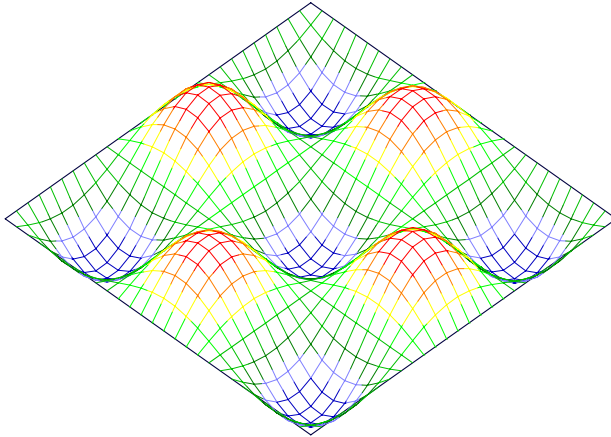
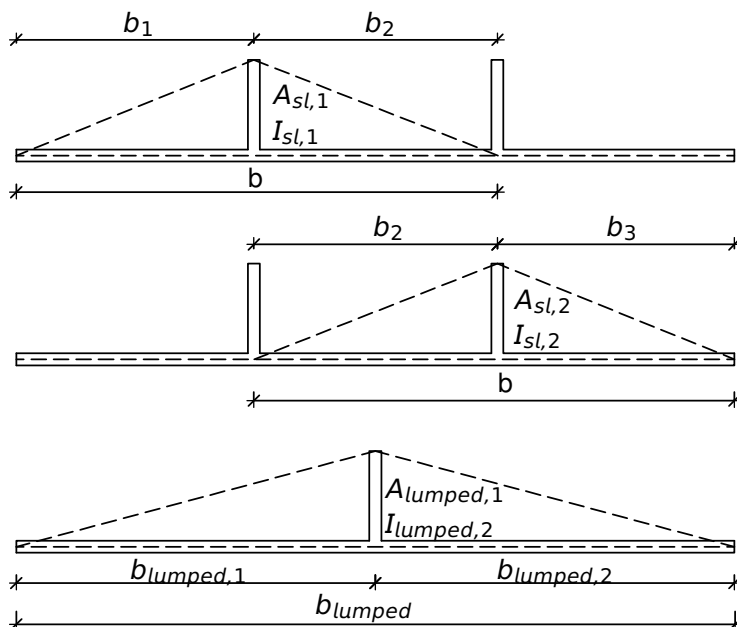

Figure 35.6: EBPlate - Buckling mode 2,  $\sigma_{cr,p} = 316.508 \text{ N/mm}^2$

### 35.4.3 EN 1993-1-5, Annex A.2

The critical plate buckling stress is calculated according to EN 1993-1-5, Annex A.2. The plate can be treated as an equivalent orthotropic plate if it is stiffened with at least three stiffeners. The plate-like behaviour is modelled by the buckling of each stiffener as a column on continuous elastic support provided by plate, while the other stiffeners acts as rigid support. Buckling of both stiffeners simultaneously is accounted for by considering a single lumped stiffener, which substitutes both stiffeners in such a way that its cross-sectional area and its second moment of area are the sum of the individual stiffeners. It is positioned at the location of the resultant of the respective forces in the individual stiffeners.



**Stiffeners I and II**

Figure 35.7

$$e_1 = 49.20 \text{ mm}, e_2 = 6.80 \text{ mm}, \bar{b}_1 = 595 \text{ mm}, \bar{b}_2 = 590 \text{ mm}$$

$$b_1 = b_2 = 600 \text{ mm}, b = b_1 + b_2 = 600 + 600 = 1200 \text{ mm}$$

$$A_{sl,1} = \left( \frac{\bar{b}_1 + \bar{b}_2}{2} + t_{sl} \right) \cdot t + b_{sl} \cdot t_{sl}$$

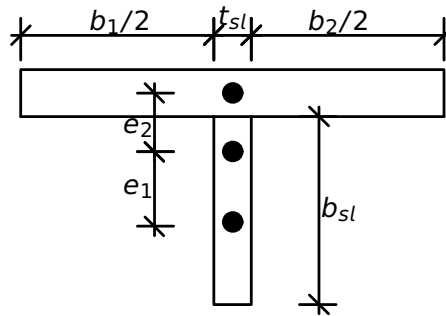
$$A_{sl,1} = \left( \frac{595 + 590}{2} + 10 \right) \cdot 12 + 100 \cdot 10 = 8230 \text{ mm}^2$$

$$I_{sl,1} = \frac{b_{sl}^3 \cdot t_{sl}}{12} + \frac{((\bar{b}_1 + \bar{b}_2) \cdot 0.5 + t_{sl,1}) \cdot t^3}{12} + b_{sl} \cdot t_{sl} \cdot e_1^2 + ((\bar{b}_1 + \bar{b}_2) \cdot 0.5 + t_{sl,1}) \cdot t \cdot e_2^2$$

$$I_{sl,1} = \frac{100^3 \cdot 10}{12} + \frac{((595 + 590) \cdot 0.5 + 10) \cdot 12}{12} + 100 \cdot 10 \cdot 49.2^2 + ((595 + 590) \cdot 0.5 + 10) \cdot 12 \cdot 6.80^2$$

$$I_{sl,1} = 3.68 \cdot 10^6 \text{ mm}^4$$

$$a_c = 4.33 \cdot \sqrt[4]{\frac{I_{sl,1} \cdot b_1^2 \cdot b_2^2}{t^3 \cdot b}}$$

$$a_c = 4.33 \cdot \sqrt[4]{\frac{3.68 \cdot 10^6 \cdot 600^2 \cdot 600^2}{12^3 \cdot 1200}}$$

$$a_c = 2998 \text{ mm}$$

As  $a \leq a_c$  ( $a = 1800 \text{ mm}$ ), the column buckles in a 1-wave mode and the buckling stress is obtained as follows:



$$\sigma_{cr,sl} = \frac{\pi^2 \cdot E \cdot I_{sl,1}}{A_{sl,1} \cdot a^2} + \frac{E \cdot t^3 \cdot b \cdot a^2}{4 \cdot \pi^2 \cdot (1 - \nu^2) \cdot A_{sl,1} \cdot b_1^2 \cdot b_2^2}$$

$$\sigma_{cr,sl} = \frac{\pi^2 \cdot 210000 \cdot 3.68 \cdot 10^6}{8230 \cdot 1800^2} + \frac{210000 \cdot 12^3 \cdot 1200 \cdot 1800^2}{4 \cdot \pi^2 \cdot (1 - 0.3^2) \cdot 8230 \cdot 600^2 \cdot 600^2}$$

$$\sigma_{cr,sl} = 322 \text{ N/mm}^2$$

In case of a stress gradient over the plate width, the critical plate buckling stress should be properly interpolated from the position of the stiffener to the most stressed edge of the plate. In this case no stress gradient over the depth of the plate is present. Therefore, the critical plate buckling stress is equal to the critical stress calculated for the buckling of the stiffener on the elastic support:

$$\sigma_{cr,p}^I = \sigma_{cr,p}^{II} = \sigma_{cr,sl} = 322 \text{ N/mm}^2$$

### Lumped stiffener

$$b_{lumped,1} = b_{lumped,2} = 900 \text{ mm}, b_{lumped} = 1800 \text{ mm}$$

$$A_{lumped} = A_{sl}^I + A_{sl}^{II} = 8230 + 8230 = 16460 \text{ mm}^4$$

$$I_{lumped} = I_{sl}^I + I_{sl}^{II} = 3.675 \cdot 10^6 + 3.675 \cdot 10^6 = 7.35 \cdot 10^6 \text{ mm}^4$$

$$a_c = 4.33 \cdot \sqrt[4]{\frac{I_{lumped} \cdot b_{lumped,1}^2 \cdot b_{lumped,2}^2}{t^3 \cdot b_{lumped}}}$$

$$a_c = 4.33 \cdot \sqrt[4]{\frac{7.35 \cdot 10^6 \cdot 900^2 \cdot 900^2}{12^3 \cdot 1800}}$$

$$a_c = 4832 \text{ mm}$$

As  $a < a_c$  ( $a = 1800 \text{ mm}$ ), the column buckles in a 1-wave mode and the buckling stress is obtained with equation:

$$\sigma_{cr,lumped} = \frac{\pi^2 \cdot E \cdot I_{lumped}}{A_{lumped} \cdot a^2} + \frac{E \cdot t^3 \cdot b_{lumped} \cdot a^2}{4 \cdot \pi^2 \cdot (1 - \nu^2) \cdot A_{lumped} \cdot b_{lumped,1}^2 \cdot b_{lumped,2}^2}$$

$$\sigma_{cr,lumped} = \frac{\pi^2 \cdot 210000 \cdot 7.35 \cdot 10^6}{16460 \cdot 1800^2} + \frac{210000 \cdot 12^3 \cdot 1800 \cdot 1800^2}{4 \cdot \pi^2 \cdot (1 - 0.3^2) \cdot 16460 \cdot 900^2 \cdot 900^2}$$

Finally we have:

$$\sigma_{cr,lumped} = 290 \text{ N/mm}^2$$

$$\sigma_{cr,p} = \min[\sigma_{cr,p}^I, \sigma_{cr,p}^{lumped}]$$

$$\sigma_{cr,p} = \min[322, 290] = 290 \text{ N/mm}^2$$

#### **35.4.4 ABAQUS**

The results from ABAQUS have been overtaken from the ECCS reference example Beg et al. [22, Example 2.4-3], see Table 35.2 for more details.

## 35.5 Conclusion

The critical plate buckling stress was calculated by using:

- SOFiSTiK
- Klöppel diagrams
- EBPlate
- ABAQUS
- EN 1993-1-5 rules

All results are compared and summarised in Table 35.2.

The methods used in the calculation give very similar results. The advantage of SOFiSTiK compared to Eurocode formulas and other tools (that are not using FEM) is that the stiffeners can be added customly. The cases with variable height of plates can be analysed as well (haunches). In conclusion, it has been shown that the SOFiSTiK results are reproduced with excellent accuracy.

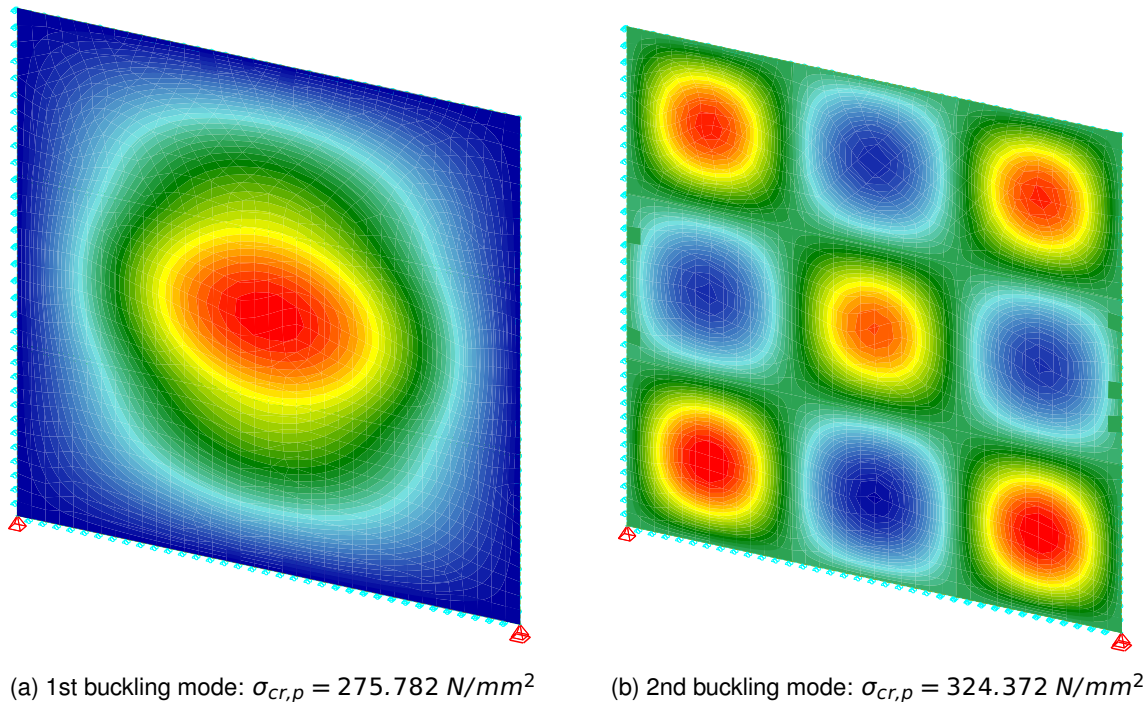

Figure 35.8: SOFiSTiK - Buckling modes

## 35.6 Literature

- [7] EN 1993-1-1: Eurocode 3: Design of concrete structures, Part 1-1: General rules and rules for buildings. CEN. 2005.
- [22] D. Beg et al. *Design of Plated Structures*. Ernst & Sohn and ECCS, 2010.
- [23] EN 1993-1-5: Eurocode 3: Design of steel structures, Part 1-5: Plated structural elements. CEN. 2006.



## 36 DCE-MC1: Creep and Shrinkage Calculation using the Model Code 2010

### Overview

<b>Design Code Family(s):</b>	MC
<b>Design Code(s):</b>	MC 2010
<b>Module(s):</b>	AQB, CSM
<b>Input file(s):</b>	<a href="#">creep_shrinkage_mc10.dat</a>

### 36.1 Problem Description

The problem consists of a simply supported beam with a rectangular cross-section of prestressed concrete, as shown in Fig. 36.1. The total creep and shrinkage is calculated.

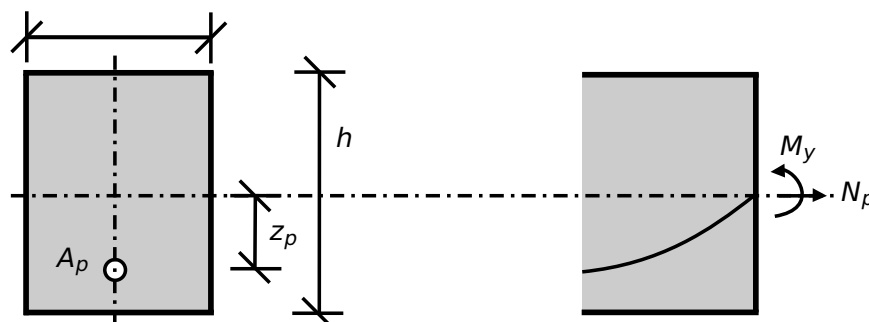

Figure 36.1: Problem Description

### 36.2 Reference Solution

This example is concerned with the calculation of creep and shrinkage on a prestressed concrete cross-section, subject to bending and prestress force. The content of this problem is covered by the following parts of fib Model Code 2010 [16]:

- Creep and Shrinkage (Section 5.1.9.4)
- Temperature effects (Section 5.1.10)

### 36.3 Model and Results

Benchmark 17 is here extended for the case of creep and shrinkage developing on a prestressed concrete simply supported beam. In benchmark 18 the calculation was made using DIN EN 1992-1-1:2004 design code. This example will explain the calculation for the case of creep and shrinkage using fib Model Code 2010 [16]. The analysed system can be seen in Fig. 36.2, with properties as defined in Table 36.1. Further information about the tendon geometry and prestressing can be found in benchmark 17. The beam consists of a rectangular cross-section and is prestressed and loaded with its own weight. A calculation of the creep and shrinkage is performed with respect to fib Model Code 2010 [16].

**Table 36.1: Model Properties**

Material Properties	Geometric Properties	Time
C 35/45	$h = 100.0 \text{ cm}$	$t_0 = 28 \text{ days}$
Y 1770	$b = 100.0 \text{ cm}$	$t_s = 0 \text{ days}$
$RH = 80 \%$	$L = 20.0 \text{ m}$	$t = 36500 \text{ days}$
	$A_p = 28.5 \text{ cm}^2$	

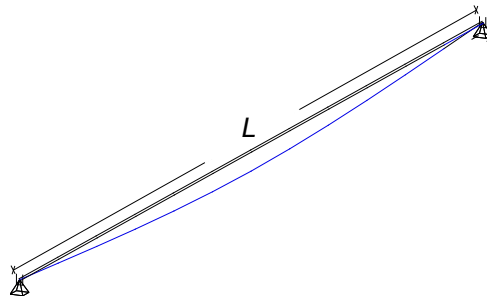
**Figure 36.2: Simply Supported Beam**
**Table 36.2: Results**

Result	AQB	CSM+AQB	Ref.
$\epsilon_{cs}$	$-27.8 \cdot 10^{-5}$	$-27.8 \cdot 10^{-5}$	$-27.82 \cdot 10^{-5}$
$\phi_{bc}(t, t_0)$	1.57	1.561	1.563

**Note:** The results from SOFiSTiK are rounded for output.

## 36.4 Design Process

### Design with respect to fib Model Code 2010 [16]

Material:

Concrete: C 35/45

5.1: Concrete

$$E_{cm} = 35000 \text{ N/mm}^2$$

5.1.7.2: Modulus of elasticity for C 35/45

$$f_{ck} = 35 \text{ N/mm}^2$$

$$f_{cm} = 43 \text{ N/mm}^2$$

5.1.4: Mean value of compressive strength  $f_{ck}$ . See the eq. (5.1-1)

Prestressing Steel: Y 1770

5.3: Prestressing Steel

$$E_p = 195000 \text{ N/mm}^2$$

$E_p$  for wires

$$f_{pk} = 1770 \text{ N/mm}^2$$

$f_{pk}$  Characteristic tensile strength of prestressing steel

**CALCULATION OF TOTAL SHRINKAGE AND SWELLING** at  $x = 10.0 \text{ m}$  midspan:

$$t_0 = 28 \text{ days}$$

$t_0$  age at first loading

$$t_s = 0 \text{ days}$$

$t_s$  concrete age at the beginning of shrinkage or swelling

$$t = 36500 \text{ days}$$

$t$  age of concrete at the moment considered

$$\epsilon_{cs}(t, t_s) = \epsilon_{cbs}(t) + \epsilon_{c ds}(t, t_s)$$

5.1.9.4.4: Eq. 5.1-75:  $\epsilon_{cs}(t, t_s)$  total shrinkage or swelling strains

#### Calculating the basic shrinkage:

$$\epsilon_{cbs}(t) = \epsilon_{cbs0}(f_{cm}) \cdot \beta_{bs}(t)$$

5.1.9.4.4: Eq. 5.1-76:  $\epsilon_{cbs}(t)$  is the basic shrinkage

$$\epsilon(f_{cm}) = -\alpha_{bs} \cdot \left( \frac{0.1 \cdot f_{cm}}{6 + 0.1 \cdot f_{cm}} \right)^{2.5} \cdot 10^{-6}$$

5.1.9.4.4: Eq. 5.1-78:  $\epsilon_{cbs0}(f_{cm})$  is the notional shrinkage coefficient

$$\alpha_{bs} = 700 \text{ for N class of cement}$$

$\alpha_{bs}$  is a coefficient, dependent on the type of cement (see table 5.1-12)

$$\epsilon(f_{cm}) = -700 \cdot \left( \frac{0.1 \cdot 43}{6 + 0.1 \cdot 43} \right)^{2.5} \cdot 10^{-6}$$

$$\epsilon(f_{cm}) = -700 \cdot (4.3/10.3)^{2.5} \cdot 10^{-6}$$

$$\epsilon(f_{cm}) = -7.8827 \cdot 10^{-5}$$

The development of drying shrinkage strain in time strongly depends on  $\beta_{ds}(t, t_s)$  factor. SOFiSTiK accounts not only for the age at start of drying  $t_s$  but also for the influence of the age of prestressing  $t_0$ . Therefore, the calculation of factor  $\beta_{ds}$  reads:

$$\beta_{bs}(t) = 1 - \exp(-0.2 \cdot \sqrt{t}) - (1 - \exp(-0.2 \cdot \sqrt{t_0}))$$

$$\beta_{bs}(t) = 1 - \exp(-0.2 \cdot \sqrt{36500}) - (1 - \exp(-0.2 \cdot \sqrt{28}))$$

$$\beta_{bs}(t) = 1 - \exp(-38.2099) - (1 - \exp(-1.0583))$$

$$\beta_{bs}(t) = 0.347$$

The basic shrinkage is calculated:

$$\begin{aligned} \epsilon_{cbs}(t) &= \epsilon_{cbs0}(f_{cm}) \cdot \beta_{bs}(t) \\ 5.1.9.4.4: \text{Eq. 5.1-76} \quad \epsilon_{cbs}(t) &= -7.8827 \cdot 10^{-5} \cdot 0.347 \\ \epsilon_{cbs}(t) &= -0.0002735269 = -2.735 \cdot 10^{-5} \end{aligned}$$

**Calculating the drying shrinkage:**

$$5.1.9.4.4: \text{Eq. 5.1-77} \quad \epsilon_{c ds}(t, t_s) = \epsilon_{c ds0}(f_{cm}) \cdot \beta_{RH}(RH) \cdot \beta_{ds}(t - t_s)$$

The drying shrinkage is calculated  $\epsilon_{c ds}(t, t_s)$  by means of the notional drying shrinkage coefficient  $\epsilon_{c ds0}(f_{cm})$ , the coefficient  $\beta_{RH}$ , taking into account the effect of the ambient relative humidity, and the function  $\beta_{ds}(t - t_s)$  describing the time development:

$$5.1.9.4.4: \text{Eq. 5.1-80} \quad \epsilon_{c ds0} = [(220 + 110 \cdot \alpha_{ds1}) \cdot \exp(-\alpha_{ds2} \cdot f_{cm})] \cdot 10^{-6}$$

See table 5.1-12

Coefficients ( $\alpha_{dsi}$ ) are depending on the type of cement.

For normal class type of cement:

$$\begin{aligned} \alpha_{ds1} &= 4 \\ \alpha_{ds2} &= 0.012 \end{aligned}$$

$$\epsilon_{c ds0}(f_{cm}) = [(220 + 110 \cdot 4) \cdot \exp(-0.012 \cdot f_{cm})] \cdot 10^{-6}$$

$$\epsilon_{c ds0}(f_{cm}) = [660 \cdot \exp(-0.516)] \cdot 10^{-6}$$

$$\epsilon_{c ds0}(f_{cm}) = 39.39 \cdot 10^{-5}$$

5.1.9.4.4: Eq. 5.1-81

$$\beta_{RH} = \begin{cases} -1.55 \cdot \left[ 1 - \left( \frac{RH}{100} \right)^3 \right], & \text{for } 40 \leq RH < 99\% \cdot \beta_{s1} \\ 0.25, & \text{for } RH \geq 99\% \cdot \beta_{s1} \end{cases}$$

$$\beta_{s1} = \left( \frac{35}{f_{cm}} \right)^{0.1} \leq 1.0$$

5.1.9.4.4: Eq. 5.1-83

$$\beta_{s1} = \left( \frac{35}{43} \right)^{0.1} = 0.9796 \leq 1.0$$

$$99\% \cdot \beta_{s1} = 99 \cdot 0.9796 = 96.98$$

$$\beta_{RH} = -1.55 \cdot \left[ 1 - \left( \frac{80}{100} \right)^3 \right] = -0.7564$$

SOFiSTiK accounts not only for the age at start of drying  $t_s$  but also for the influence of the age of prestressing, so the time development function reads:

5.1.9.4.4: Eq. 5.1-82

$$\beta_{ds}(t - t_s) = \sqrt{\frac{t - t_s}{0.035 \cdot h^2 + (t - t_s)}} - \sqrt{\frac{t_0 - t_s}{0.035 \cdot h^2 + (t_0 - t_s)}}$$

$$\beta_{ds}(t - t_s) = \sqrt{\frac{36500}{0.035 \cdot 500^2 + 36500}} - \sqrt{\frac{28}{0.035 \cdot 500^2 + 28}}$$

$$\beta_{ds}(t - t_s) = 0.8981 - 0.05669 = 0.8416$$

The drying shrinkage is calculated:

$$\epsilon_{c ds}(t, t_s) = \epsilon_{c ds0}(f_{cm}) \cdot \beta_{RH} \cdot \beta_{ds}(t - t_s)$$



$$\epsilon_{c_{ds}}(t, t_s) = 39.39 \cdot 10^{-5} \cdot (-0.7564) \cdot 0.8416$$

$$\epsilon_{c_{ds}}(t, t_s) = -25.08 \cdot 10^{-5}$$

The total shrinkage or swelling strain is calculated:

$$\epsilon_{cs}(t, t_s) = \epsilon_{cbs}(t) + \epsilon_{c_{ds}}(t, t_s)$$

$$\epsilon_{cs}(t, t_s) = (-2.735 + (-25.08)) \cdot 10^{-5} = -27.82 \cdot 10^{-5}$$

### CALCULATION OF TOTAL CREEP at x=10.0 m midspan:

The creep coefficient:

$$\phi(t, t_0) = \phi_{bc}(t, t_0) + \phi_{dc}(t, t_0)$$

### Calculating the basic creep:

$$\phi_{bc}(t, t_0) = \beta(f_{cm}) \cdot \beta_{bc}(t, t_0)$$

$$\text{with: } \beta_{bc}(f_{cm}) = \frac{1.8}{(f_{cm})^{0.7}} = \frac{1.8}{(43)^{0.7}} = 0.12937$$

and the time development function:

$$\beta_{bc}(t, t_0) = \ln \left[ \left( \frac{30}{t_{0,adj}} + 0.035 \right)^2 \cdot (t - t_0) + 1 \right]$$

$$t_{0,adj} = t_{0,T} \cdot \left[ \frac{9}{2 + t_{0,T}^{1.2}} + 1 \right]^\alpha \geq 0.5 \text{ days}$$

$$t_T = \sum_{i=1}^n \Delta t_i \cdot \exp \left[ 13.65 - \frac{4000}{273 + T(\Delta t_i)} \right]$$

$$t_{0,T} = \sum_{i=1}^n 28 \cdot \exp \left[ 13.65 - \frac{4000}{273 + 20} \right] = 27.947 \text{ days}$$

$\alpha = 0$  for N class cement

$$t_{0,adj} = 27.947 \cdot \left[ \frac{9}{2 + 27.947^{1.2}} + 1 \right]^0 = 27.947 \geq 0.5 \text{ days}$$

$$\beta_{bc}(t, t_0) = \ln \left[ \left( \frac{30}{27.947} + 0.035 \right)^2 \cdot 36472 + 1 \right]$$

$$\beta_{bc}(t, t_0) = 10.71$$

The basic creep coefficient:

$$\phi_{bc}(t, t_0) = 0.12937 \cdot 10.71 = 1.385$$

### Calculating the drying creep:

The drying coefficient may be estimated from:

$$\phi_{dc}(t, t_0) = \beta_{dc} f_{cm} \cdot \beta(RH) \cdot \beta_{dc}(t_0) \cdot \beta_{dc}(t, t_0)$$

with:

$$\beta_{dc}(f_{cm}) = \frac{412}{(f_{cm})^{1.4}} = 2.1283$$

5.1.9.4.3(b): Eq. 5.1-63:  $\phi(t, t_0)$  is the creep coefficient;  $\phi_{bc}(t, t_0)$  is the basic creep coefficient according to eq. 5.1-64;  $\phi_{dc}(t, t_0)$  is the drying creep coefficient according to eq. 5.1-67

5.1.9.4.3(b): Eq. 5.1-66:  $\beta_{bc}(t, t_0)$  is the time development function

$t_{0,adj}$  is the modified age at loading  $t_0$

5.1.10.2: Eq. 5.1-85;  $t_T$  the adjusted concrete age, during the effect of elevated or reduced temperatures on the maturity of concrete

5.1.9.4.3b: Eq. 5.1-67;  $\phi_{dc}(t, t_0)$  is the drying creep coefficient

5.1.9.4.3: Eq.5.1-68

5.1.9.4.3(b): Eq. 5.1-69

$$\beta(RH) = \frac{1 - \frac{RH}{100}}{\sqrt[3]{0.1 \cdot \frac{h}{100}}} = \frac{1 - \frac{80}{100}}{\sqrt[3]{0.1 \cdot \frac{500}{100}}} = 0.251$$

5.1.9.4.3: Eq.5.1-70

$$\beta_{dc}(t_0) = \frac{1}{0.1 + t_{0,adj}^{0.2}} = \frac{1}{0.1 + 27.947} = 0.4886$$

5.1.9.4.3(b): Eq. 5.1-71a;  $\beta_{dc}(t, t_0)$  the development of drying creep with time

$$\beta_{dc}(t, t_0) = \left[ \frac{t - t_0}{\beta_h + (t - t_0)} \right]^{\gamma(t_0)}$$

5.1.9.4.3: Eq. 5.1-71b

with:

$$\gamma(t_0) = \frac{1}{2 + \frac{3.5}{\sqrt{t_{0,adj}}}} = \frac{1}{2.962} = 0.3376$$

5.1.9.4.3: Eq. 5.1-71d

$$\alpha_{f_{cm}} = \sqrt{\frac{35}{f_{cm}}} = \sqrt{\frac{35}{43}} = 0.9021$$

5.1.9.4.3: Eq. 5.1-71c

$$\beta_h = 1.5 \cdot h + 250 \cdot \alpha_{f_{cm}} \leq 1500 \cdot \alpha_{f_{cm}}$$

$$\beta_h = 1.5 \cdot 500 + 250 \cdot 0.9021 = 975.548 \leq 1352.15$$

5.1.9.4.3: Eq. 5.1-71a

$$\beta_{dc}(t, t_0) = \left[ \frac{36500 - 28}{975.548 + (36500 - 28)} \right]^{0.3376} = 0,9911$$

The drying creep coefficient:

$$\phi_{bc}(t, t_0) = 2.1283 \cdot 0.251 \cdot 0.4886 \cdot 0.9911 = 0.2597$$

The total creep coefficient:

$$\phi(t, t_0) = \phi_{bc}(t, t_0) + \phi_{dc}(t, t_0)$$

$$\phi(t, t_0) = 1.385 + 0.2587 = 1.64$$

According to Model Code 2010 [16], the creep value is related to the tangent Young's modulus  $E_c$ , where  $E_c$  being defined as  $1.05 \cdot E_{cm}$ . To account for this, SOFiSTiK adopts this scaling for the computed creep coefficient (in SOFiSTiK, all computations are consistently based on  $E_{cm}$ ).

$$\phi(t, t_0) = 1.64/1.05 = 1.56$$

## 36.5 Conclusion

This example shows the calculation of the creep and shrinkage using fib Model Code 2010 [16]. It has been shown that the results are in very good agreement with the reference solution.

## 36.6 Literature

[16] fib Model Code 2010. *fib Model Code for Concrete Structures 2010*. International Federation for Structural Concrete (fib). 2010.

---



## 37 DCE-MC2: Creep and Shrinkage Calculation using the Model Code 1990

### Overview

<b>Design Code Family(s):</b>	MC
<b>Design Code(s):</b>	MC 1990
<b>Module(s):</b>	AQB, CSM
<b>Input file(s):</b>	<a href="#">creep_shrinkage_mc90.dat</a>

### 37.1 Problem Description

The problem consists of a simply supported beam with a rectangular cross-section of prestressed concrete, as shown in Fig. 37.1. The total creep and shrinkage is calculated.

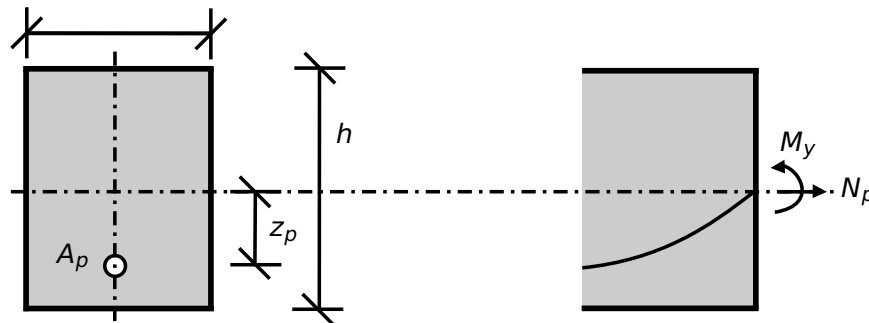

Figure 37.1: Problem Description

### 37.2 Reference Solution

This example is concerned with the calculation of creep and shrinkage on a prestressed concrete cs, subject to bending and prestress force. The content of this problem is covered by the following parts of CEB-FIP Model Code 1990 [24]:

- Creep and Shrinkage (Section 2.1.6.4)
- Temperature effects (Section 2.1.8)

In this Benchmark the total creep and shrinkage will be examined.

### 37.3 Model and Results

Benchmark 17 is here extended for the case of creep and shrinkage developing on a prestressed concrete simply supported beam. The analysed system can be seen in Fig. 37.2, with properties as defined in Table 37.1. Further information about the tendon geometry and prestressing can be found in Benchmark 17. The beam consists of a rectangular cs and is prestressed and loaded with its own weight. A calculation of the creep and shrinkage is performed with respect to CEB-FIP Model Code 1990 [24].

**Table 37.1: Model Properties**

Material Properties	Geometric Properties	Time
C 35/45	$h = 100.0 \text{ cm}$	$t_0 = 28 \text{ days}$
Y 1770	$b = 100.0 \text{ cm}$	$t_s = 0 \text{ days}$
$RH = 80 \%$	$L = 20.0 \text{ m}$	$t = 36500 \text{ days}$
	$A_p = 28.5 \text{ cm}^2$	

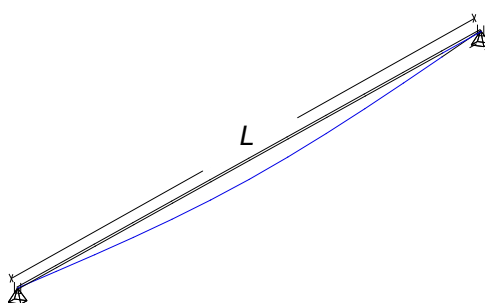
**Figure 37.2: Simply Supported Beam**
**Table 37.2: Results**

Result	AQB	CSM+AQB	Ref.
$\epsilon_{cs}$	$-25.1 \cdot 10^{-5}$	$25.1 \cdot 10^{-5}$	$25.146 \cdot 10^{-5}$
$\phi_0$	1.57	-	1.566
$\phi(t, t_0)$	1.48	1.476	1.47

**Note:** The results from SOFiSTiK are rounded for output.

## 37.4 Design Process

### Design with respect to CEB-FIP Model Code 1990 [24]

Material:

Concrete: C 35/45

$$E_{cm} = 35000 \text{ N/mm}^2$$

$$f_{ck} = 35 \text{ N/mm}^2$$

$$f_{cm} = 43 \text{ N/mm}^2$$

Prestressing Steel: Y 1770

$$E_p = 195000 \text{ N/mm}^2$$

$$f_{pk} = 1770 \text{ N/mm}^2$$

**CALCULATION OF TOTAL SHRINKAGE AND SWELLING** at  $x = 10.0 \text{ m}$  midspan:

$$t_0 = 28 \text{ days}$$

$$t_s = 0 \text{ days}$$

$$t = 36500 \text{ days}$$

The total shrinkage or swelling strains  $\epsilon_{cs}(t, t_s)$  may be calculated from

$$\epsilon_{cs}(t, t_s) = \epsilon_{cs0} \cdot \beta_s(t - t_s)$$

#### Calculating the notional shrinkage:

The notional shrinkage coefficient may be obtained from

$$\epsilon_{cs0} = \epsilon_s(f_{cm}) \cdot \beta_{RH}$$

with:

$$\epsilon_s(f_{cm}) = \left[ 160 + 10 \cdot \beta_{sc} \cdot \left( 9 - \frac{f_{cm}}{f_{cm0}} \right) \right] \cdot 10^{-6}$$

$$\epsilon_s(f_{cm}) = \left[ 160 + 10 \cdot 5 \cdot \left( 9 - \frac{43}{10} \right) \right] \cdot 10^{-6}$$

$$\epsilon_s(f_{cm}) = 39.5 \cdot 10^{-5}$$

$$\beta_{RH} = -1.55 \cdot \beta_{sRH} \text{ for } 40 \% \leq RH < 99 \%$$

$$\beta_{sRH} = 1 - \left( \frac{RH}{RH_0} \right)^3 = 1 - \left( \frac{80}{100} \right)^3 = 0.488$$

$$\beta_{RH} = -1.55 \cdot 0.488 = -0.7564$$

$$\epsilon_{cs0} = 39.5 \cdot 10^{-5} \cdot (-0.7564) = -29.8778$$

2.1 Concrete classification and constitutive relations

2.1.4.2: Modulus of elasticity for C 35/45

2.1.3.2: Mean value of compressive strength  $f_{cm}$ . See the eq. (2.1-1)

5.3: Prestressing Steel

$E_p$  for wires

$f_{pk}$  Characteristic tensile strength of prestressing steel

$t_0$  age at first loading

$t_s$  concrete age at the beginning of shrinkage or swelling

$t$  age of concrete at the moment considered

2.1.6.4.4: Eq. 2.1-74;  $\epsilon_{cs}(t, t_s)$  is the total or swelling strain

2.1.6.4.4: Eq. 2.1-75;  $\epsilon_{cs0}$  is the notional shrinkage coefficient

2.1.6.4.4: Eq.2.1-76;  $\beta_{sc}$  is a coefficient which depends on the type of cement, for N class of cement  $\beta_{sc} = 5$ ;  $f_{cm0} = 10 \text{ MPa}$

2.1.6.4.4: Eq.2.1-77

2.1.6.4.4: Eq.2.1-78;  $RH_0 = 100 \%$

2.1.6.4.4: Eq.2.1-79;  $\beta_s(t - t_s)$  is the development of shrinkage with time;  $h_0 = 100 \text{ mm}$ ;  $t_1 = 1 \text{ day}$

The development of shrinkage with time is given by:

$$\beta_s(t - t_s) = \left[ \frac{(t - t_s)/t_1}{350 \cdot (h/h_0)^2 + (t - t_s)/t_1} \right]^{0.5}$$

SOFISTIK accounts not only for the age at start of drying  $t_s$  but also for the influence of the age of prestressing, so the time development function reads:

$$\beta_s = \beta_s(t - t_s) - \beta_s(t_0 - t_s)$$

$$\beta_s = \left[ \frac{36500}{350 \cdot 5^2 + 36500} \right]^{0.5} - \left[ \frac{28}{350 \cdot 5^2 + 28} \right]^{0.5}$$

$$\beta_s = 0.8981 - 0.05647 = 0.8416$$

The total shrinkage or swelling strain is calculated:

$$\epsilon_{cs}(t, t_s) = \epsilon_{cs0} \cdot \beta_s$$

$$\epsilon_{cs}(t, t_s) = -29.8778 \cdot 10^{-5} \cdot 0.8416 = 25.146 \cdot 10^{-5}$$

### CALCULATION OF TOTAL CREEP at $x=10.0 \text{ m}$ midspan:

The creep coefficient may be calculated from:

$$\phi(t, t_0) = \phi_0 \cdot \beta_c(t - t_0)$$

2.1.6.4.3(b): Eq. 2.1-64;  $\phi(t, t_0)$  is the creep coefficient

The notional creep coefficient may be estimated from:

$$\phi_0 = \phi_{RH} \cdot \beta(f_{cm}) \cdot \beta(t_0)$$

2.1.6.4.3(b): Eq. 2.1-65;  $\phi_0$  is the notional creep coefficient

with:

$$\phi_{RH} = 1 + \frac{1 - (RH/RH_0)}{0.46 \cdot (h/h_0)^{1/3}}$$

2.1.6.4.3(b): Eq.2.1-66;  $h$  is the notional size of member in [mm],  $h = \frac{2 \cdot A_c}{u}$

2.1.6.4.3(b): Eq. 2.1-66

$$\phi_{RH} = 1 + \frac{1 - (80/100)}{0.46 \cdot (500/100)^{1/3}} = 1 + \frac{0.2}{0.78658} = 1.254$$

2.1.6.4.3(b): Eq. 2.1-67

$$\beta(f_{cm}) = \frac{5.3}{(f_{cm}/f_{cm0})^{0.5}} = \frac{5.3}{(43/10)^{0.5}} = 2.556$$

The adjusted time  $t_0$  is given by:

2.1.8.2: Eq. 2.1-87;  $t_{0,T}$  is the adjusted age of concrete at loading (days)

$$t_{0,T} = \sum_{i=1}^n \Delta t_i \cdot \exp \left[ 13.65 - \frac{4000}{273 + T(\Delta t_i)/T_0} \right]$$

$$t_{0,T} = \sum_{i=1}^n 28 \cdot \exp \left[ 13.65 - \frac{4000}{273 + 20/1} \right] = 27.947 \text{ days}$$

2.1.6.4.3(c): Eq.2.1-71; the effect of type of cement on the creep coefficient of concrete may be taken into account by using the modified age at loading  $t_{0,adj}$ ;  $\alpha = 0$  for cement class N

$$t_{0,adj} = t_{0,T} \cdot \left[ \frac{9}{2 + (t_{0,T}/t_{1,T}^{1.2})} + 1 \right]^\alpha \geq 0.5 \text{ days}$$

$$t_{0,adj} = 27.947 \cdot \left[ \frac{9}{2 + 27.947^{1.2}} + 1 \right]^0 = 27.947 \geq 0.5 \text{ days}$$

2.1.6.4.3(b): Eq. 2.1-68

$$\beta(t_0) = \frac{1}{0.1 + (t_0/t_1)^{0.2}} = \frac{1}{0.1 + (27.947/1)^{0.2}} = 0.48862$$



The development of creep with time is given by:

$$\beta_c(t-t_0) = \left[ \frac{(t-t_0)/t_1}{\beta_h + (t-t_0)/t_1} \right]^{0.3}$$

2.1.6.4.3(b): Eq. 2.1-70

with:

$$\beta_H = 150 \cdot \left\{ 1 + \left( 1.2 \cdot \frac{RH}{RH_0} \right)^{18} \right\} \cdot \frac{h}{h_0} + 250 \leq 1500$$

2.1.6.4.3(b): Eq. 2.1-71;  $t_1 = 1 \text{ day}$ ;  
 $RH_0 = 100 \%$ ;  $h_0 = 100 \text{ mm}$

$$\beta_H = 150 \cdot \left\{ 1 + \left( 1.2 \cdot \frac{80}{100} \right)^{18} \right\} \cdot \frac{500}{100} + 250 \leq 1500$$

$$\beta_H = 1359.702 \leq 1500$$

$$\beta_c(t-t_0) = \left[ \frac{(36500-28)/1}{1359.702 + (36500-28)/1} \right]^{0.3} = 0.989$$

$$\phi_0 = 1.254 \cdot 2.556 \cdot 0.48862 = 1.566$$

The creep coefficient:

$$\phi(t, t_0) = 1.56613 \cdot 0.989 = 1.5489$$

The creep value is related to the tangent Youngs modulus, where the tangent modulus being defined as  $1.05 \cdot E_{cm}$ . To account for this, SOFiSTiK adopts this scaling for the computed creep coefficient (in SOFiSTiK, all computations are consistently based on the secant modulus of elasticity).

$$\phi(t, t_0) = \frac{1.5489}{1.05} = 1.47$$

## **37.5 Conclusion**

This example shows the calculation of the creep and shrinkage using Model Code 1990 [24]. It has been shown that the results are in very good agreement with the reference solution.

## **37.6 Literature**

[24] CEB-FIP Model Code 1990. *Model Code for Concrete Structures 1990*. Euro-International Concrete Committee. 1991.

---

## 38 DCE-SIA1: Punching of flat slabs acc. SIA 262

### Overview

<b>Design Code Family(s):</b>	SIA
<b>Design Code(s):</b>	SIA 262
<b>Module(s):</b>	BEMESS
<b>Input file(s):</b>	<a href="#">slab_punching_sia262_2013.dat</a>

### 38.1 Problem Description

The problem consists of a flat slab. The structure under consideration is a five-storey residential building with the geometry and main dimensions given in Fig. 38.1. The design of slab against punching at the columns is discussed in the following.

For the concrete, strength class C30/37 ( $f_{ck} = 30 \text{ MPa}$ ,  $\gamma_c = 1.5$ ) is assumed, for the reinforcing steel, grade B500B ( $f_{yk} = 500 \text{ MPa}$ ,  $E_s = 205 \text{ GPa}$ ,  $\gamma_s = 1.15$ , ductility class B). The factored design load accounting for self-weight, dead load and imposed load is  $q_d = 15.6 \text{ kN/m}^2$ .

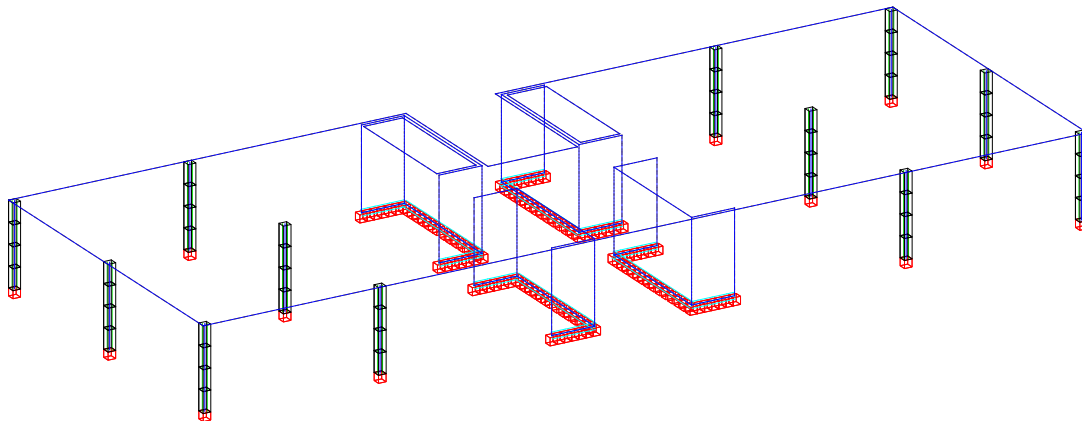

(a) SOFiSTiK Model

Figure 38.1: View of building

The width of the slab is  $h = 26 \text{ cm}$  as shown in Fig. 38.2.



Table 38.1: (continued)

Material Properties	Geometric Properties	Loading
	$d = 21.0 \text{ cm}$	

## 38.2 Reference Solution

This example is concerned with the punching of flat slabs. The content of this problem is covered by the following parts of SIA 262:2013 [25]:

- Construction materials (Section 2.2 )
- Dimensioning values (Section 4.2)
- Shear force (Section 4.3.3)
- Punching (Section 4.3.6)

## 38.3 Model and Results

The goal of the preliminary design is to check if the dimensions of the structure are reasonable with respect to the punching shear strength and if punching shear reinforcement is needed.

In the reference example the reaction forces are estimated by using contributive areas. The results are given in Table 38.2.

Table 38.2: Results

Result	SOF.	Ref.
Inner column C5 (Node 1070)		
$u$	1.681 m	1.681 m
$k_e$	0.9	0.9
$u_{red}$	1.5129 m	1.5129 m
$\psi_x$	1.37 %	1.325 %
$\psi_y$	1.38 %	1.424 %
$k_r$	1.05	1.02786
$V_{Rd,c}$	353.5 kN	347.36 kN
$V_{Rdc,max}$	706.9 kN	694.69 kN
$A_{sw}$	8.78 cm <sup>2</sup>	8.766 cm <sup>2</sup>

## 38.4 Design Process<sup>1</sup>

The calculation steps of the reference solution are presented below.

### STEP 1: Material

SIA 262:2013; 4.2.1

Concrete 30/37

Characteristic value of cylinder compressive strength

$$f_{ck} = 30 \text{ N/mm}^2$$

Conversion factor  $\eta_{fc}$ ; 4.2.1.2; Eq. (26)

$$\eta_{fc} = \left(\frac{30}{f_{ck}}\right)^{1/3} = \left(\frac{30}{30}\right)^{1/3} = 1.00 \leq 1.00$$

The dimensioning value of the concrete compressive strength; 2.3.2.3; Eq. (2)

$$f_{cd} = \frac{\eta_{fc} \cdot \eta_t \cdot f_{ck}}{\gamma_c} = \frac{1 \cdot 1 \cdot 30}{1.5} = 20 \text{ N/mm}^2$$

The dimensioning value of shear stress limit; 2.3.2.4; Eq.(3)

$$\tau_{cd} = \frac{0.3 \cdot \eta_t \cdot \sqrt{f_{ck}}}{\gamma_c} = \frac{0.3 \cdot 1.0 \cdot \sqrt{30}}{1.5} = 1.095 \text{ N/mm}^2$$

$$D_{max} = 32 \text{ mm}$$

### STEP 2: Reinforcement

SIA 262:2013; 4.2.2

Steel B500B (flexural and transverse reinforcement)

$$f_{yd} = 435 \text{ MPa}$$

$$E_s = 205000 \text{ MPa}$$

Ductility class: B

For  $\phi 10 @ 200 \text{ mm} / \phi 16 @ 200 \text{ mm}$

### STEP 3: Cross-section

$$\begin{aligned} d &= h - d_1 \\ &= 26 - \left(4.8 + \frac{1.6}{2}\right) \\ &= 20.4 \text{ cm} \end{aligned}$$

4.3.6.2; Fig. 21 and Fig. 22

### STEP 4: Calculating the control perimeter

Inner:

$$\begin{aligned} u &= 2 \cdot a + 2 \cdot b + d_v \cdot \pi \\ &= 2 \cdot 26 + 2 \cdot 26 + 20.4 \cdot 3.14 \\ &= 168.1 \text{ cm} \end{aligned}$$

In BEMESS the shear force  $V_d$  is equal to column reaction force minus the applied load within the control perimeter  $g_d \cdot A_c$ . The value  $q_d$  is not taken into account.

$$V_d = 686.1 \text{ kN}$$

<sup>1</sup>The sections mentioned in the margins refer to SIA 262:2013 [25] unless otherwise specified.

Bemess takes into account the min. value of  $k_e$ .

For inner columns  $k_e = 0.9$ , SIA 262:2013, 4.3.6.2.5

$$k_e = \min \left( 0.9; 1 + \frac{1}{1 + \frac{e_u}{b}} \right) \quad (38.1)$$

$$e_u = \left| \frac{M_d}{V_d} - \Delta e \right| = \left| \frac{5.46 \text{ kNm}}{686.1 \text{ kN}} \right| = 7.95 \text{ mm}$$

In case of inner columns, the centroid of the column corresponds to the centroid of the control perimeter. Therefore,  $\Delta e = 0$

$$\begin{aligned} A_c &= b_c^2 + 4 \cdot b_c \cdot \frac{d_v}{2} + \frac{d_v^2}{4} \cdot \pi \\ &= 0.26^2 + 4 \cdot 0.26 \cdot \frac{0.204}{2} + \frac{0.204^2}{4} \cdot \pi \\ &= 0.2063 \text{ m}^2 \end{aligned}$$

$$b_u = \sqrt{\frac{4}{\pi} \cdot A_c} = \sqrt{\frac{4}{\pi} \cdot 0.2063} = 0.5129 \text{ m} = 512.9 \text{ mm}$$

According to Eq. 38.1:

$$\begin{aligned} k_e &= \min \left( 0.9, \frac{1}{1 + \frac{e_u}{b}} \right) \\ &= \min \left( 0.9, \frac{1}{1 + \frac{e_u}{b}} \right) \\ &= \min \left( 0.9, \frac{1}{1 + \frac{7.95}{512.9}} \right) \\ &= \min(0.9, 0.98) \\ &= 0.9 \end{aligned}$$

Where  $e_u$  is the eccentricity of the resultant of shear forces with respect to the centroid of the basic control perimeter and  $b_u$  is the diameter of a circle with the same surface as the region inside the basic control perimeter.

Reduced control perimeter is calculated:

$$u_{red} = k_e \cdot u = 0.9 \cdot 168.1 = 151.29 \text{ cm}$$

#### STEP 5: Rotations

The distances  $r_{s,x}$  and  $r_{s,y}$  are calculated from the results of the flexural analysis, one can obtain the distances between the center of the column

and the point, at which the bending moments are zero.

$$r_{sx} = 1.166 \text{ m}$$

$$r_{sy} = 1.248 \text{ m}$$

The average moment of the strip is calculated by the integration of the moments at the strip section. Since the flexural moments  $m_{d,x}$  and  $m_{d,y}$  are negative, the absolute value of the twisting moment  $m_{d,x}$  needs to be subtracted so that the absolute value of  $m_{sd,x}$  and  $m_{sd,y}$  will be maximized:

$$m_{sd,x} = m_{d,x} - |m_{d,xy}|$$

$$m_{sd,y} = m_{d,y} - |m_{d,xy}|$$

By using FEM analysis:

$$m_{sd,x} = 105.53 \text{ kNm/m}$$

$$m_{sd,y} = 105.81 \text{ kNm/m}$$

The representative width  $b_s$ ; 4.3.6.4.6;  
Eq. (60)

The representative width is calculated:

$$\begin{aligned} b_s &= 1.5 \cdot \sqrt{r_{sx} \cdot r_{sy}} \leq l_{min} \\ &= 1.5 \cdot \sqrt{1.248 \cdot 1.166} \\ &= 1.8094 \text{ m} \end{aligned}$$

BEMESS calculates the  $\psi$  value by using LoA (Level of Approximation) III. LoA I is used only at beginning of the calculation for iteration, when:

$$\frac{m_{sd,x}}{m_{Rd}} = 1.$$

Rotation  $\psi$ ; 4.3.6.4.1 and 4.3.6.4.2; Eq.  
(59)

For Level of Approximation III:

$$\begin{aligned} \psi_x &= 1.2 \cdot \frac{r_{sx}}{d} \cdot \frac{f_{sd}}{E_s} \cdot \left( \frac{m_{sd,x}}{m_{Rd}} \right)^{3/2} \\ &= 1.2 \cdot \frac{1.166}{0.204} \cdot \frac{434.78}{205000} \cdot \left( \frac{105.53}{112.306} \right)^{3/2} \\ &= 1.325 \% \end{aligned}$$

$$\begin{aligned} \psi_y &= 1.2 \cdot \frac{r_{sy}}{d} \cdot \frac{f_{sd}}{E_s} \cdot \left( \frac{m_{sd,y}}{m_{Rd}} \right)^{3/2} \\ &= 1.2 \cdot \frac{1.248}{0.204} \cdot \frac{434.78}{205000} \cdot \left( \frac{105.81}{112.306} \right)^{3/2} \\ &= 1.424 \% \end{aligned}$$

The governing value is  $\psi = \max(\psi_x, \psi_y) = 1.424 \%$

$k_r$ ; 4.3.6.3.2; Eq. (58)

The coefficient  $k_r$ :



$$\begin{aligned}
 k_r &= \frac{1}{0.45 + 0.18 \cdot \psi \cdot d \cdot k_g} \\
 &= \frac{1}{0.45 + 0.18 \cdot \psi \cdot d \cdot k_g} \\
 &= \frac{1}{0.45 + 0.18 \cdot 0.01424 \cdot 204 \cdot 1} \\
 &= 1.02786
 \end{aligned}$$

In BEMESS there isn't any option to set the  $D_{max}$  value and the  $D_{max}$  is strictly defined:

- For normal concrete  $D_{max} = 32 \text{ mm} \rightarrow k_g = 1.0$
- For high-strength and lightweight concrete, the  $D_{max} = 0 \rightarrow k_g = 3$ .

### STEP 6: Punching strength with and without shear reinforcement

According to SIA 262:2013 the punching strength without shear reinforcement is calculated:

4.3.6.3.1; Eq. (57)

$$\begin{aligned}
 V_{Rd,c} &= k_r \cdot \tau_{cd} \cdot d_v \cdot u \\
 &= 1.02786 \cdot 1.095 \cdot 0.204 \cdot 1.5129 \\
 &= 0.34736 \text{ MN} = 347.36 \text{ kN}
 \end{aligned}$$

$V_d > V_{Rd,c} \rightarrow$  shear/punching reinforcement is necessary

Calculating the maximum punching strength  $V_{Rd,max}$

4.3.6.5.7; Eq. (69)

$$\begin{aligned}
 V_{Rd,max} &= 2 \cdot k_r \cdot \tau_{cd} \cdot d_v \cdot u_{red} \leq 3.5 \cdot \tau_{cd} \cdot d_v \cdot u_{red} \\
 &= 2 \cdot 1.0278 \cdot 1.095 \cdot 0.204 \cdot 1.5129 \leq 3.5 \cdot 1.095 \cdot 0.204 \cdot 1.5129 \\
 &= 0.69469 \text{ MN} \leq 1.182 \text{ MN} \\
 &= 694.69 \text{ kN}
 \end{aligned}$$

Punching strength with shear reinforcement:

4.3.6.5; Eq. (65) and Eq. (66)

$$V_{d,s} = \max(V_d - V_{Rd,c}; 0.5 \cdot V_d)$$

$$V_d - V_{Rd,c} = 686.1 - 347.36 = 338.74 \text{ kN}$$

$$V_d \cdot 0.5 = 686.1 \cdot 0.5 = 343.05 \text{ kN}$$

$$V_{d,s} = \max(338.74; 343.05) = 343.05 \text{ kN}$$

Calculating the reinforcement:

$$\begin{aligned} \sin\beta \cdot A_{sw} &= \frac{V_{d,s}}{k_e \cdot \sigma_{sd}} \\ &= \frac{343.05}{0.9 \cdot 43.478} \\ &= \underline{\underline{8.766 \text{ cm}^2}} \end{aligned}$$

4.3.6.5.4; Eq. (68)

where  $\sigma_{sd}$  is calculated according:

$$\begin{aligned} \sigma_{sd} &= \frac{E_s \cdot \psi}{6} \cdot \left( 1 + \frac{f_{bd}}{f_{sd}} \cdot \frac{d}{\phi_{sw}} \right) \leq f_{sd} \\ &= \frac{205000 \cdot 0.01424}{6} \cdot \left( 1 + \frac{2.703}{434.78} \cdot \frac{204}{16} \right) \leq 434.78 \\ &= 487.00 \cdot (1 + 0.006216 \cdot 12.75) \leq 434.78 \\ &= 525.60 \leq 434.78 \\ &= 434.78 \text{ N/mm}^2 \end{aligned}$$

Please note that in BEMESS,  $\sin\beta = 1.0$ .

#### STEP 7: Failure outside the shear reinforcement

To avoid failure outside the shear reinforcement area, BEMESS iterates the perimeter until the shear strength  $V_{Rdc} \geq V_d$ .

In this example, the calculating value of the effective depth  $d_v$  is equal to the effective depth  $d$  minus the distance from concrete cover  $c$  on the bottom surface of the slab:  $d_{v,out} = d - c = 204 - 40 = 164 \text{ mm}$

$$V_{Rd,c,out} = 2 \cdot k_r \cdot \tau_{cd} \cdot d_{v,out} \cdot u_{out} = V_d$$

$$u_{out} = \frac{0.6861}{1.02786 \cdot 1.095 \cdot 0.164} = 3.7170 \text{ m}$$

$$r_{out} = \frac{u_{out} - 4 \cdot b_c}{2 \cdot \pi} = \frac{3.717 - 4 \cdot 0.26}{2 \cdot \pi} = 0.426 \text{ m}$$

## 38.5 Conclusion

This example shows the calculation of punching of flat slabs and it has been shown that the results are reproduced with excellent accuracy.

## 38.6 Literature

- [16] fib Model Code 2010. *fib Model Code for Concrete Structures 2010*. International Federation for Structural Concrete (fib). 2010.
  - [25] *SIA 262:2013 Concrete Structures*. Swiss Society of Engineers and Architects. 2013.
  - [26] S. Lips, A. Muttoni, and M.F. Ruiz. "Punching of flat slabs: Design Example". In: *fib Model Code 2010* (2011).
  - [27] A. Muttoni et al. *Background to fib Model Code 2010 shear provisions - part II: punching shear*. Tech. rep. fib, 2013.
-