



Benchmark Example No. 28

Design of a T-section for bending and shear using Design Elements

VERiFiCATION
DCE-EN28 Design of a T-section for bending and shear using Design Elements

VERiFiCATION Manual, Service Pack 2022-12 Build 74

Copyright © 2023 by SOFiSTiK AG, Nuremberg, Germany.

SOFiSTiK AG

HQ Nuremberg
Flataustraße 14
90411 Nürnberg
Germany

T +49 (0)911 39901-0
F +49(0)911 397904

Office Garching
Parkring 2
85748 Garching bei München
Germany

T +49 (0)89 315878-0
F +49 (0)89 315878-23

info@sofistik.com
www.sofistik.com

This manual is protected by copyright laws. No part of it may be translated, copied or reproduced, in any form or by any means, without written permission from SOFiSTiK AG. SOFiSTiK reserves the right to modify or to release new editions of this manual.

The manual and the program have been thoroughly checked for errors. However, SOFiSTiK does not claim that either one is completely error free. Errors and omissions are corrected as soon as they are detected.

The user of the program is solely responsible for the applications. We strongly encourage the user to test the correctness of all calculations at least by random sampling.

Front Cover

Arnulfsteg, Munich Photo: Hans Gössing

Overview

Design Code Family(s):	DIN
Design Code(s):	DIN EN 1992-1-1
Module(s):	DECREATOR, AQB
Input file(s):	t-beam_de.dat

1 Problem Description

This section demonstrates design elements as a solution to the problem of a member modeled out of beam and quad elements; which is to be designed using a given cross section. An instance of a beam having a T-section as shown in Fig. 2 is considered. The beam constitutes a loaded floor slab shown in Fig. 1.

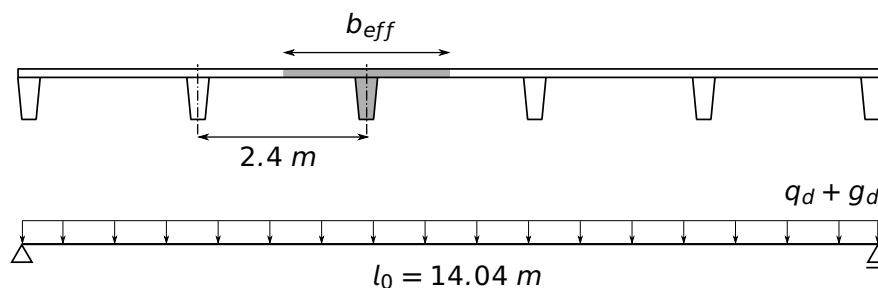

Figure 1: Sketch of the slab and longitudinal system of single t-beam member

2 Reference Solution

The reference inputs and results of this problem were adopted from an extended solution to a similar problem in section 7 of [1]. The standard aspects of the design procedures are covered in the following parts of the Eurocode DIN EN 1992-1-1 [2]:

- Concrete (Section 3.1)
- Reinforcing Steel (Section 3.2)
- Bending with or without axial force (Section 6.1)
- Shear (Section 6.2)

3 Model and Results

The beam member is assumed to be simply supported with out carrying normal force. It's finite element model is formed in SOFiSTiK using quad elements for the flange and an eccentrically coupled beam element for the web. The self-weight parts of the design loads are applied separately to each element. After analysis, a design element spanning the entire beam length is then defined using the program DECREATOR. The design element then integrates the stresses of the quad elements at its design sections, and superimposes these with the corresponding forces of the eccentric beam to result in the design values of the bending moment M_{Ed} and shear force V_{Ed} .

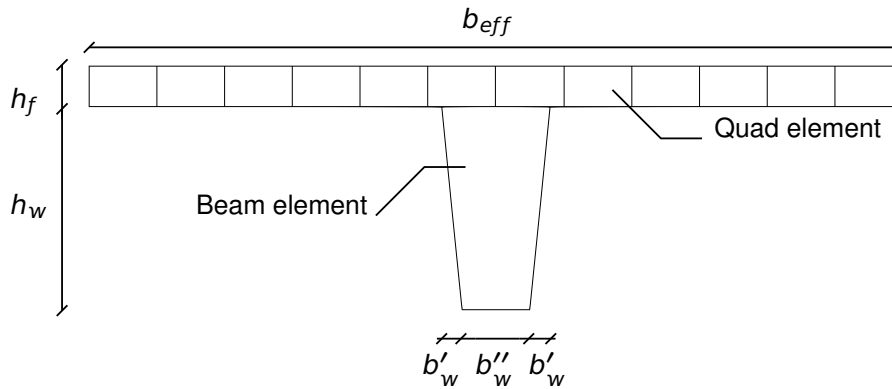

Figure 2: Cross sectional view of the model out of quad and beam elements

The sectional properties and loadings of the member are given in table 1. The analysis gives results of the individual quad and beam elements. DECRETOR is then used to integrate all forces at the explicit design sections for use in design. Since, in this model, the centroid of the chosen cross section lies on the design element, no transformation of forces from design element axis to the centroid takes place during computation. However, this full cross section will be used for design. The final analysis and design results are given in Table 2, the reference calculation procedures of which are presented in the following section.

Table 1: Model Properties

Material Properties	Geometric Properties	Loading
<i>C 35/45</i>	$h_w = 60.0 \text{ cm}$	$q_d = 8.85 \text{ kN/m}^2$
<i>B 500B</i>	$h_f = 12.0 \text{ cm}$	$g_{d,flange} = 6.41 \text{ kN/m}^2$
	$d = 62.20 \text{ cm}$	$g_{d,web} = 5.27 \text{ kN/m}$
	$b_{eff} = 240 \text{ cm}$	
	$b''_w = 20.0 \text{ cm}$	
	$b'_w = 6.0 \text{ cm}$	
	$b_w = 26.0 \text{ cm}$	

Summarized in Table 2 are the results of the reference example in [1] (Ref.-2), those obtained based on design tables (Ref.-1) as presented in the next section, and those from SOFiSTiK computations. For simplification purposes the reference example uses rough approximate procedures in obtaining reinforcement areas, while the hand calculation and the SOFiSTiK results come from iterative approximations and are as close to the exact requirements as possible.

In this regard, in calculating the reinforcement area in Ref.-2, the full thickness of the flange was assumed to roughly approximate the compressive zone. The moment arm is thereby reduced and hence it resulted in a larger reinforcement area. In a similar manner, the shear reinforcements in Ref.-2 are larger since the example selects a suitable reinforcement diameter and spacing in advance to compute the area, which is more than the required amount.

Table 2: Results

	SOF.	Ref.-1	Ref.-2
M_{Ed} [kNm]	1085.85	1086.0	1086.0
$A_{s,req} / s$ [cm ² /m]	39.42	41.34	44.60
V_{Ed} [kN] for $x = 13.680$ m	269.56	272.0	272.0
$A_{s,req} / s$ [cm ² /m] for $x = 13.680$ m	8.42	9.3	15.71

4 Design Process

Design with respect to DIN EN 1992-1-1 [2]:¹

Design of the T-beam for bending and shear are carried out using the T-cross section, as shown in figure 3. References on the side margins can be further reviewed for notations and explanations.

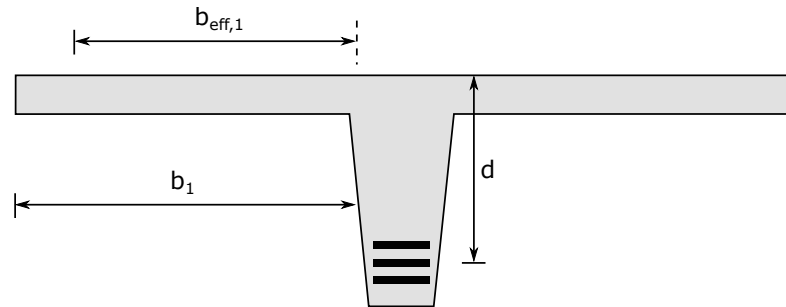

Figure 3: Full cross-section used for design

Material partial factors and design strengths:

(NDP) 2.4.2.4: (1), Tab. 2.1DE: Partial factors for materials

$$\text{Concrete: } \gamma_c = 1.50$$

$$\text{Steel: } \gamma_s = 1.15$$

Tab. 3.1: Strength for concrete

3.1.6: (1)P, Eq. (3.15): $\alpha_{cc} = 0.85$ considering long term effects

3.2.2: (3)P: yield strength $f_{yk} = 500$ MPa

$$f_{ck} = 35 \text{ MPa}$$

$$f_{cd} = \alpha_{cc} \cdot f_{ck} / \gamma_c = 0.85 \cdot 35 / 1.5 = 19.83 \text{ MPa}$$

$$f_{yk} = 500 \text{ MPa}$$

$$f_{yd} = f_{yk} / \gamma_s = 500 / 1.15 = 434.78 \text{ MPa}$$

Design for bending:

$$\text{Design section at: } x = l_0 / 2.0 = 14.40 / 2.0 = 7.20 \text{ m}$$

$$\text{Design bending moment: } M_{Ed} = 1086.0 \text{ kNm}$$

Effective width of flange b_{eff} :

5.3.2.1: (3) Eq. (5.7) and Fig. (5.3) for notations

$$b_{eff} = \sum b_{eff,i} + b_w \leq b$$

5.3.2.1: (3) Eq. (5.7a)

$$b_{eff,i} = 0.2 \cdot b_i + 0.1 \cdot l_0 \leq 0.2 \cdot l_0$$

$$b_i = 0.5 \cdot (b_{eff} - b_w)$$

$$b_{1,2} = 0.5 \cdot (2.4 - 0.26) = 1.07 \text{ m}$$

$$b_{eff1,2} = 0.2 \cdot 1.07 + 0.1 \cdot 14.40 = 1.65 \text{ m} \leq 0.2 \cdot l_0$$

$$\text{But, } b_{eff1,2} > b_{1,2} = 1.07 \text{ m}$$

$$\therefore b_{eff} = 2 \cdot 1.07 + 0.26 = 2.40 \text{ m}$$

¹The sections mentioned in the margins refer to DIN EN 1992-1-1 (German National Annex) [2], unless otherwise specified

Reinforcement depth d , for three layers of re-bars with $\phi 25$:

$$c_{nom} = c_{min} + \Delta c_{dev} = 25 + 10 = 35 \text{ mm}$$

$$d = h - c_{nom} - 2.5 \cdot \phi$$

$$d = 720 - 35 - 2.5 \cdot 25 = 620 \text{ mm}$$

Design cross-section:

$$b_{eff}/h_f/b_w/h/d = 2.40/0.12/0.26/0.72/0.62 \text{ m}$$

Using design table for T-beams:

$$\mu_{Eds} = \frac{M_{Eds}}{b_{eff} \cdot d^2 \cdot f_{cd}} = \frac{1086.0}{2.4 \cdot 0.62^2 \cdot 19.83} = 0.0594$$

For $\mu_{Eds} = 0.0594$ and $b_{eff}/b_w = 9.23$,

table 9.4 of [3] results in $\omega_1 = 0.0609$

Required bottom-reinforcement for bending at the design section:

$$A_{s1} = \frac{1}{f_{yd}} (\omega_1 \cdot b_{eff} \cdot d \cdot f_{cd}) = 41.34 \text{ cm}^2$$

Design for Shear:

Design section at: $x = 0.5 \cdot 0.2 + 0.62 = 0.72 \text{ m}$

Design shear force: $V_{Rd,s} = 272.0 \text{ kN}$

Vertical reinforcement from shear resistance:

$$V_{Rd,s} = (A_{sw}/S) \cdot z \cdot f_{ywd} \cdot \cot \theta$$

$$(A_{sw}/S) = \frac{V_{Rd,s}}{z \cdot f_{ywd} \cdot \cot \theta}$$

$$\cot \theta = 1.2$$

$$z = 0.9d = 0.9 \cdot 0.62 = 0.558 \text{ m}$$

Required total shear reinforcement at the design section:

$$(A_{sw}/S) = \frac{272.0}{0.558 \cdot 434.78 \cdot 1.2} = 9.33 \text{ cm}^2/\text{m}$$

4.4.1.1:(2) Eq. (4.1) Nominal concrete cover

Assumptions: Stirrups $\phi_{st} \leq 10 \text{ mm}$
 Longitudinal reinforcement: $\phi 25$ in 3-layers
 Reinforcement and spacing: $(3 + 2)/2 = 2.5$

μ_s - Table for T-beams (Tab. 9.4) [3]

Equation from table 9.4 in [3]

Distance from center of elastomer support with thickness $b=200 \text{ mm}$ [1]

6.2.3:(3) Eq. (6.8)

6.2.3:(2), simplified for pure bending [1]

5 Conclusion

It has been demonstrated in this example that, using Design Elements in SOFiSTiK, a structural member modeled out of different finite element types can be designed with a unifying full cross section. The critical internal forces were well approximated and reasonable design results were obtained.

6 Literature

- [1] *Beispiele zur Bemessung nach Eurocode 2 - Band 1: Hochbau*. Ernst & Sohn. Deutschen Beton- und Bautechnik-Verein E.V. 2011.
 - [2] *EN 1992-1-1: Eurocode 2: Design of concrete structures, Part 1-1: General rules and rules for buildings*. CEN. 2004.
 - [3] K. Holschemacher, T. Müller, and F. Lobisch. *Bemessungshilfsmittel für Betonbauteile nach Eurocode 2 Bauingenieure*. 3rd. Ernst & Sohn, 2012.
-