



Benchmark Example No. 10

## Shear between web and flanges of T-sections

**VERiFiCATION**  
**DCE-EN10 Shear between web and flanges of T-sections**

VERiFiCATION Manual, Service Pack 2022-12 Build 74

Copyright © 2023 by SOFiSTiK AG, Nuremberg, Germany.

**SOFiSTiK AG**

HQ Nuremberg  
Flataustraße 14  
90411 Nürnberg  
Germany

T +49 (0)911 39901-0  
F +49(0)911 397904

Office Garching  
Parkring 2  
85748 Garching bei München  
Germany

T +49 (0)89 315878-0  
F +49 (0)89 315878-23

[info@sofistik.com](mailto:info@sofistik.com)  
[www.sofistik.com](http://www.sofistik.com)

This manual is protected by copyright laws. No part of it may be translated, copied or reproduced, in any form or by any means, without written permission from SOFiSTiK AG. SOFiSTiK reserves the right to modify or to release new editions of this manual.

The manual and the program have been thoroughly checked for errors. However, SOFiSTiK does not claim that either one is completely error free. Errors and omissions are corrected as soon as they are detected.

The user of the program is solely responsible for the applications. We strongly encourage the user to test the correctness of all calculations at least by random sampling.

**Front Cover**

Arnulfsteg, Munich Photo: Hans Gössing

## Overview

<b>Design Code Family(s):</b>	DIN
<b>Design Code(s):</b>	DIN EN 1992-1-1
<b>Module(s):</b>	AQB
<b>Input file(s):</b>	<a href="#">t-beam_shear_web_flange.dat</a>

## 1 Problem Description

The problem consists of a T-beam section, as shown in Fig. 1. The cs is designed for shear, the shear between web and flanges of T-sections is considered and the required reinforcement is determined.

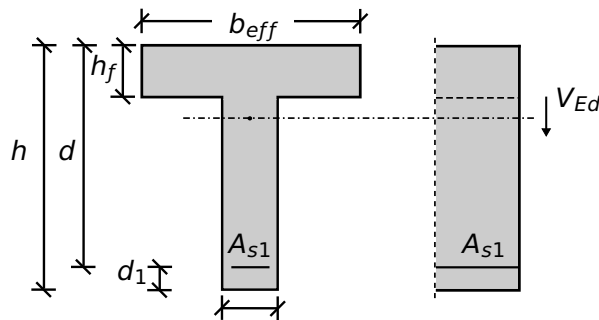

Figure 1: Problem Description

## 2 Reference Solution

This example is concerned with the shear design of T-sections, for the ultimate limit state. The content of this problem is covered by the following parts of DIN EN 1992-1-1:2004 [1]:

- Design stress-strain curves for concrete and reinforcement (Section 3.1.7, 3.2.7)
- Guidelines for shear design (Section 6.2)

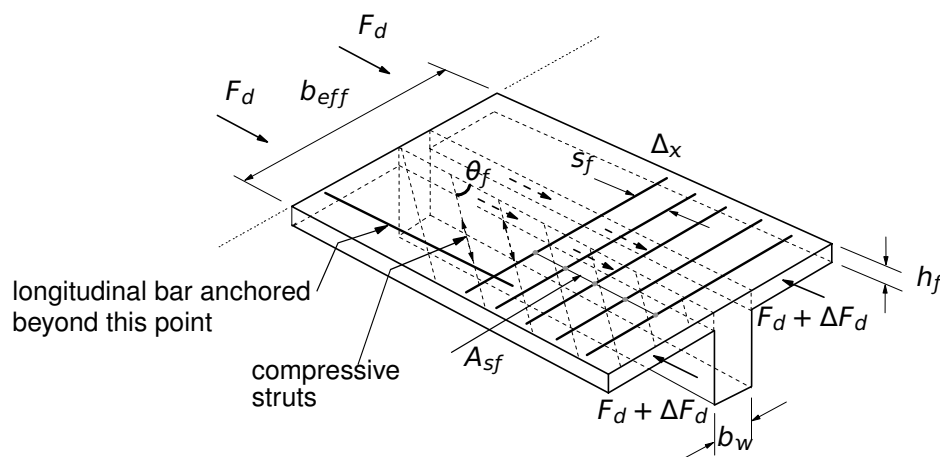

Figure 2: Connection between flange and web in T-sections

The design stress-strain diagram for reinforcing steel considered in this example, consists of an inclined top branch, as presented in Fig. 3 and as defined in DIN EN 1992-1-1:2004 [1] (Section 3.2.7).

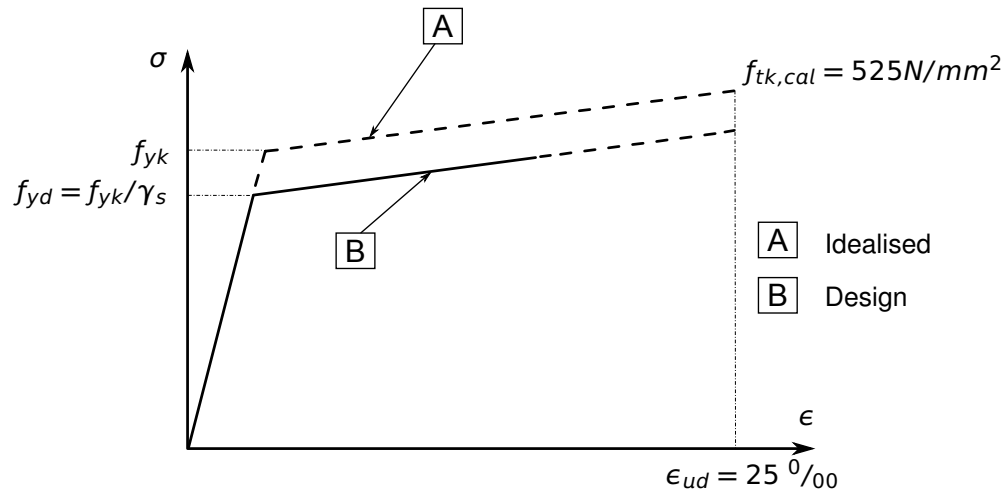

Figure 3: Idealised and Design Stress-Strain Diagram for Reinforcing Steel

### 3 Model and Results

The T-section, with properties as defined in Table 1, is to be designed for shear, with respect to DIN EN 1992-1-1:2004 (German National Annex) [1], [2]. The structure analysed, consists of a single span beam with a distributed load in gravity direction. The cross-section geometry, as well as the shear cut under consideration can be seen in Fig. 4.

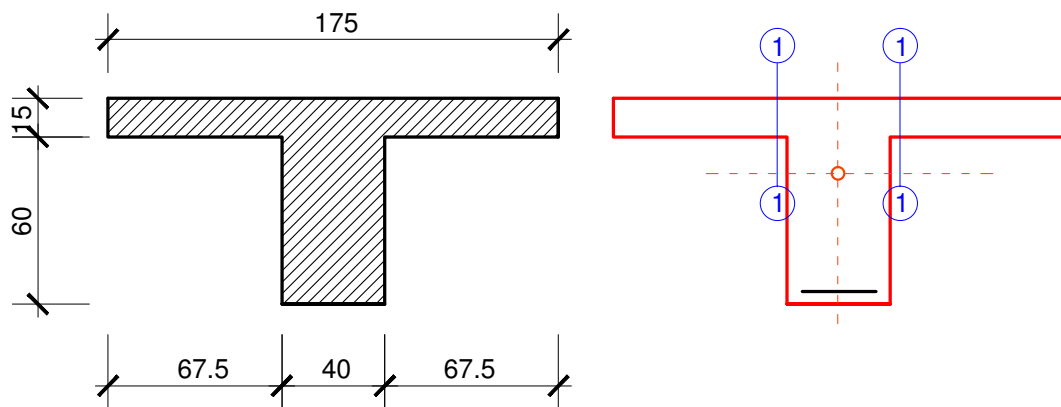

Figure 4: Cross-section Geometry, Properties and Shear Cuts

Table 1: Model Properties

Material Properties	Geometric Properties	Loading
C 20/25	$h = 75.0 \text{ cm}$	$P_g = 155 \text{ kN/m}$
B 500A	$h_f = 15 \text{ cm}, h_w = 60.0 \text{ cm}$ $d_1 = 7.0 \text{ cm}$ $b_w = 40 \text{ cm}$ $b_{eff,i} = 67.5 \text{ cm}, b_{eff} = 175 \text{ cm}$	

The system with its loading as well as the moment and shear force are shown in Fig. 5. The reference calculation steps [3] are presented in the next section and the results are given in Table 2.

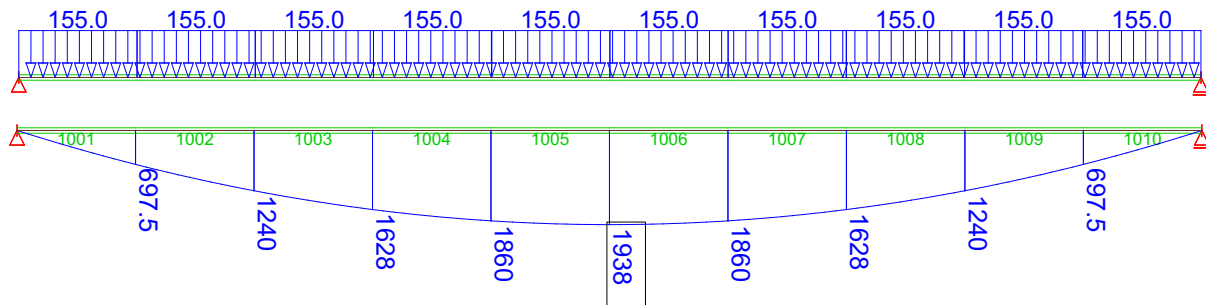

Figure 5: Loaded Structure, Resulting Moment and Shear Force

Table 2: Results

At beam 1001	SOF.	Ref.
$A_{s1}$ [ $cm^2$ ] at $x = 1.0$ m	23.26	23.27
$A_{sf} / s_f$ [ $cm^2/m$ ]	5.71	5.79
$V_{Rd,c}$ [kN]	61.05	61.2
$V_{Rd,max}$ [kN]	711.61	712.53
$\cot \theta$	1.62	1.619
$z$ [cm] at $x = 1.0$ m	65.72	65.7
$V_{Ed} = \Delta F_d$ [kN]	403.65	409.36

## 4 Design Process<sup>1</sup>

### Design with respect to DIN EN 1992-1-1:2004 (NA) [1] [2]:<sup>2</sup>

Material:

(NDP) 2.4.2.4: (1), Tab. 2.1DE: Partial factors for materials

Concrete:  $\gamma_c = 1.50$

Steel:  $\gamma_s = 1.15$

Tab. 3.1: Strength for concrete

3.1.6: (1)P, Eq. (3.15):  $\alpha_{cc} = 0.85$  considering long term effects

3.2.2: (3)P: yield strength  $f_{yk} = 500$  MPa

3.2.7: (2), Fig. 3.8

$f_{ck} = 25$  MPa

$f_{cd} = \alpha_{cc} \cdot f_{ck} / \gamma_c = 0.85 \cdot 25 / 1.5 = 14.17$  MPa

$f_{yk} = 500$  MPa

$f_{yd} = f_{yk} / \gamma_s = 500 / 1.15 = 434.78$  MPa

$\sigma_{sd} = 456.52$  MPa

#### Design loads

- Design Load for beam 1001,  $x=0.0$  m:

$M_{Ed,x=0.0\text{ m}} = 0.0$  kNm

- Design Load for beam 1001,  $x=1.0$  m:

$M_{Ed,x=1.0\text{ m}} = 697.5$  kNm

#### Calculating the longitudinal reinforcement:

- For beam 1001,  $x=0.0$  m

$\mu = 0 \rightarrow A_{s1} = 0$

$$\mu_{Eds} = \frac{M_{Eds}}{b_{eff} \cdot d^2 \cdot f_{cd}} = \frac{0.0 \cdot 10^{-3}}{1.75 \cdot 0.68^2 \cdot 14.17} = 0.00$$

- For beam 1001,  $x=1.0$  m

$$\mu_{Eds} = \frac{M_{Eds}}{b_{eff} \cdot d^2 \cdot f_{cd}} = \frac{697.5 \cdot 10^{-3}}{1.75 \cdot 0.68^2 \cdot 14.17} = 0.0608$$

Tab. 9.2 [4]:  $\omega$ —Table for up to C50/60 without compression reinforcement

$N_{Ed} = 0$

$\omega \approx 0.063$ ,  $\zeta \approx 0.967$  and  $\xi \approx 0.086$  (interpolated)

$$A_{s1} = \frac{1}{\sigma_{sd}} \cdot (\omega \cdot b \cdot d \cdot f_{cd} + N_{Ed})$$

$$A_{s1} = \frac{1}{456.52} \cdot (0.063 \cdot 1.75 \cdot 0.68 \cdot 14.17) \cdot 100^2 = 23.27 \text{ cm}^2$$

$$z = \zeta \cdot d = 0.967 \cdot 0.68 \text{ m} \approx 65.7 \text{ cm}$$

#### Calculating the shear between flange and web

The shear force, is determined by the change of the longitudinal force, at the junction between one side of a flange and the web, in the separated flange:

6.2.4 (3): Eq. 6.20

<sup>1</sup>The tools used in the design process are based on steel stress-strain diagrams, as defined in [1] 3.2.7:(2), Fig. 3.8, which can be seen in Fig. 3.

<sup>2</sup>The sections mentioned in the margins refer to DIN EN 1992-1-1:2004 (German National Annex) [1], [2], unless otherwise specified.

$$\Delta F_d = \left( \frac{M_{Ed,x=1.0}}{z} - \frac{M_{Ed,x=0.0}}{z} \right) \cdot \frac{h_f \cdot b_{eff,i}}{h_f \cdot b_{eff}}$$

For beam 1001 ( $x=0.00$  m)  $\rightarrow M_{Ed} = 0.00$  therefore:

$$\Delta F_d = \left( \frac{697.5}{0.657} - 0 \right) \cdot \frac{0.675}{1.75} = 409.36 \text{ kN}$$

In AQB output  $\Delta F_d = T$  [kN/m]

The longitudinal shear stress  $v_{Ed}$  at the junction between one side of a flange and the web is determined by the change of the normal (longitudinal) force in the part of the flange considered, according to:

$$v_{Ed} = \frac{\Delta F_d}{h_f \cdot \Delta x}$$

DIN EN 1992, 6.2.4 (3), Eq. 6.20:  $h_f$  is the thickness of flange at the junctions,  $\Delta x$  is the length under consideration,  $\Delta F_d$  is the change of the normal force in the flange over the length  $\Delta x$

In our case  $\Delta x = 1.0$  because the beam length is = 1.00 m.

Please note that AQB is outputting the results per length.

$$v_{Ed} = \frac{409.36}{15 \cdot 100} = 0.272 \text{ kN/m}^2 = 2.72 \text{ MPa}$$

In AQB output  $v_{Ed} = \tau - V$

### Checking the maximum $v_{Rd,max}$ value to prevent crushing of the struts in the flange

To prevent crushing of the compression struts in the flange, the following condition should be satisfied:

$$v_{Ed} \leq v_{Rd,max} = v \cdot f_{cd} \cdot \sin \theta_f \cdot \cos \theta_f$$

DIN EN 1992, 6.2.4 (4), Eq. 6.22

$$v_{Rd,max} = v \cdot f_{cd} \cdot \sin \theta_f \cdot \cos \theta_f$$

According to DIN EN 1992-1-1, NDP 6.2.4(4):

$$v = v_1$$

$$v_1 = 0.75 \cdot v_2$$

DIN EN 1992, NDP 6.2.3 (3), Eq. 6.22

$$v_2 = 1.1 - \frac{f_{ck}}{500} \leq 1.0$$

$$v_2 = 1.1 - \frac{20}{500} = 1.1 - 0.04 = 1.06 \geq 1.0 \rightarrow v_2 = 1.0$$

$$v_1 = 0.75 \cdot 1.0 = 0.75 \rightarrow v = 0.75$$

The  $\theta$  value is calculated:

$$v_{Rd,cc} = c \cdot 0.48 \cdot f_{ck}^{1/3} \cdot \left( 1 - 1.2 \cdot \frac{\sigma_{cd}}{f_{cd}} \right) \cdot b_w \cdot z$$

DIN EN 1992, NDP 6.2.3 (2), Eq. NA.6.7b:  $\sigma_{cd} = N_{Ed}/A_c$ ,  $c=0.5$

$$b_w \rightarrow h_f, \quad z \rightarrow \Delta x, \quad c = 0.5$$

$$v_{Rd,cc} = c \cdot 0.48 \cdot f_{ck}^{1/3} \cdot \left( 1 - 1.2 \cdot \frac{\sigma_{cd}}{f_{cd}} \right) \cdot h_f \cdot \Delta x$$

$$v_{Rd,cc} = 0.5 \cdot 0.48 \cdot 25^{1/3} \cdot \left( 1 - 1.2 \cdot \frac{0}{14.17} \right) \cdot 0.15 \cdot 1.0$$

$$v_{Rd,cc} = 0.1052 \text{ MN} = 105.26 \text{ kN}$$

DIN EN 1992, NDP 6.2.3 (2), Eq. NA.6.7a

$$1.0 \leq \cot\theta \leq \frac{1.2 + 1.4 \cdot \Delta\sigma_{cd}/f_{cd}}{1 - V_{Rd,cc}/V_{Ed}} \leq 3.0$$

$$\cot\theta = \frac{1.2}{1 - 105.26/409.36} = 1.619$$

$$\tan\theta = \frac{1}{\cot\theta} = \frac{1}{1.619} = 0.619 \rightarrow \theta = 31.75^\circ$$

$$v_{Rd,max} = 0.75 \cdot 14.17 \cdot \sin 31.75^\circ \cdot \cos 31.75^\circ = 4.7502 \text{ MPa}$$

$$V_{Rd,max} = v_{Rd,max} \cdot h_f \cdot \Delta x = 4.7502 \cdot 0.15 \cdot 1.0 = 0.71253 \text{ MN}$$

$$V_{Rd,max} = 712.53 \text{ kN}$$

#### Checking the value $v_{Rd,c}$

If  $v_{Ed}$  is less than or equal to  $v_{Rd,c} = k \cdot f_{ctd}$  no extra reinforcement above that for flexure is required.

$$v_{Rd,c} = k \cdot f_{ctd}$$

For concrete C 25/30  $\rightarrow f_{ctd} = 1.02 \text{ MPa}$

$$v_{Rd,c} = 0.4 \cdot 1.02 = 0.408 \text{ MPa}$$

$$V_{Rd,c} = v_{Rd,c} \cdot h_f \cdot \Delta x = 0.408 \cdot 15 \cdot 100 = 61.2 \text{ kN}$$

- Calculating the necessary transverse reinforcement:

DIN EN 1992, 6.2.4 (4), Eq. 6.21

$$a_{sf} = \frac{v_{Ed} \cdot h_f}{\cot\theta_f \cdot f_{yd}}$$

$$a_{sf} = \frac{2.72 \cdot 0.15}{1.619 \cdot 434.78} \cdot 100^2 = 5.79 \text{ cm}^2$$



## 5 Conclusion

This example is concerned with the calculation of the shear between web and flanges of T-sections. It has been shown that the results are reproduced with good accuracy.

## 6 Literature

- [1] *DIN EN 1992-1-1/NA: Eurocode 2: Design of concrete structures, Part 1-1/NA: General rules and rules for buildings - German version EN 1992-1-1:2005 (D), Nationaler Anhang Deutschland - Stand Februar 2010.* CEN. 2010.
  - [2] F. Fingerloos, J. Hegger, and K. Zilch. *DIN EN 1992-1-1 Bemessung und Konstruktion von Stahlbeton- und Spannbetontragwerken - Teil 1-1: Allgemeine Bemessungsregeln und Regeln für den Hochbau.* BVPI, DBV, ISB, VBI. Ernst & Sohn, Beuth, 2012.
  - [3] *Beispiele zur Bemessung nach Eurocode 2 - Band 1: Hochbau.* Ernst & Sohn. Deutschen Beton- und Bautechnik-Verein E.V. 2011.
  - [4] K. Holschemacher, T. Müller, and F. Lobisch. *Bemessungshilfsmittel für Betonbauteile nach Eurocode 2 Bauingenieure.* 3rd. Ernst & Sohn, 2012.
-